

Hygienic Hangers and Supports

CH Series
Smooth Bore Series
Stanchions
Height Adjusters
Accessories

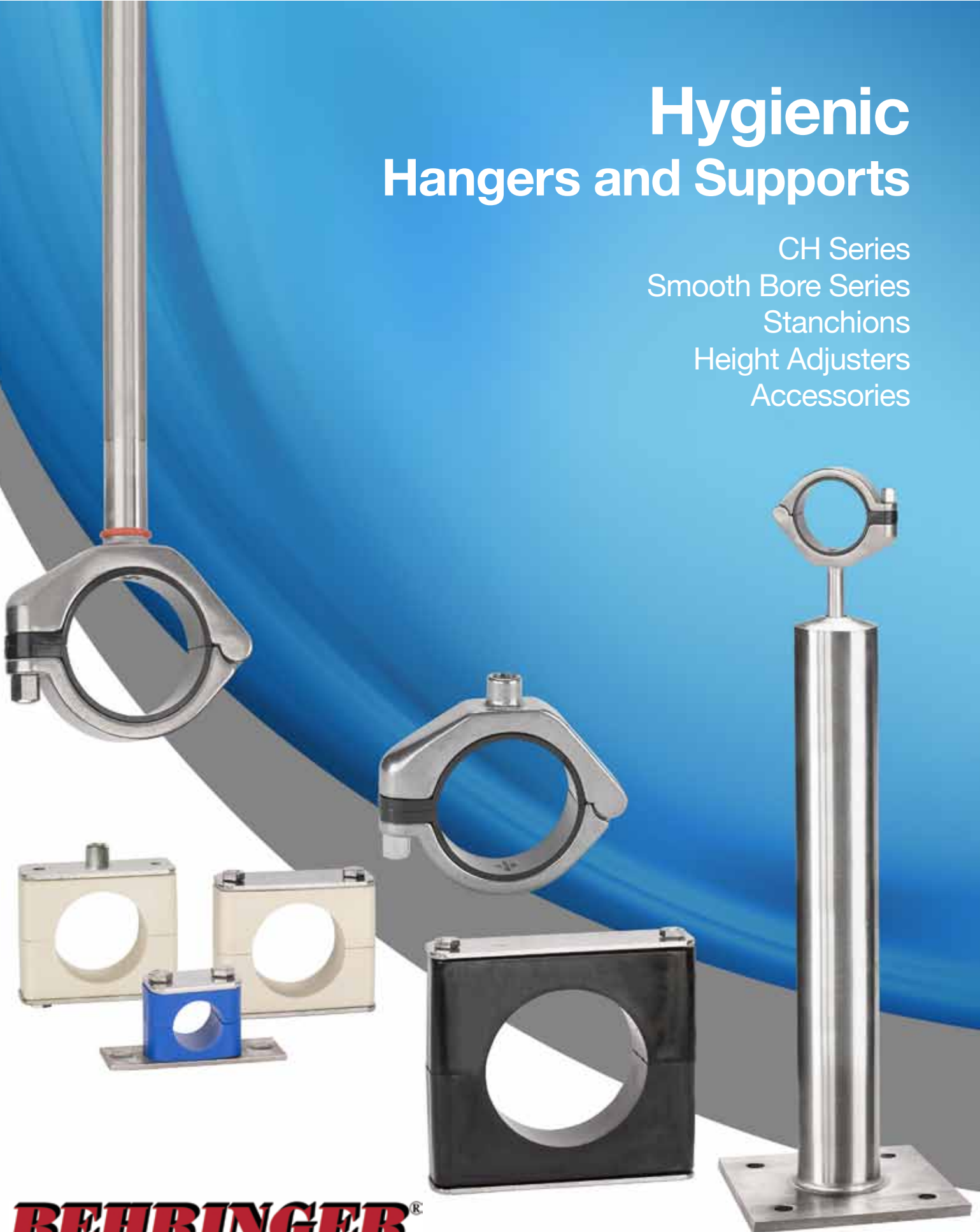

BEHRINGER[®]

Introduction	3
Introduction	Applications
Product	Assistance
Guarantee	Please Read
CH Series	5
CH-Dynamic Mount Hanger	CHT-Rigid Threaded Mount Hanger
CHR-Rigid Mount Hanger	Threaded Support Rod
CHW-Weld Plate Mount Support	Tapered Guides
Smooth Bore Series	30
Mounting / Hardware Configuration	Fig. 203 RAL-1 Rail Mounting
Fig. 200 Weld Plate Mount	Fig. 204 Stacking Kit
Fig. 201 Hang Plate Mount	Fig. 211 Unistrut Mount
Fig. 202 Base Plate Mount	Fig. 221 Rod Mount
Stanchions	64
Fig. 223 Telescopic Adjusting Round Floor Stand	
Fig. 224 CH Series Rod Stand Plate	
Fig. 225 Telescopic Adjusting Stanchion - Hang Mount	
Fig. 226 Telescopic Adjusting Stanchion - Floor Mount	
Height Adjusters	78
Rigid Height Adjusters	
Dynamic Height Adjusters	
Accessories	82
Technical Data	83
Proper Slope for Drainability	Slope Conversion Chart
Recommended Mounting Practices	Shear Force Diagram
Material Properties	Spacing of Hangers
Surface Finishing for Metal Parts	

Introduction

Thank you for choosing Behringer, the world's leading manufacturer of Pipe and Tube supports. Behringer has been manufacturing pipe clamps and support systems for over 30 years, and has developed a reputation in the industrial and sanitary markets that is second to none. We have made developments and product improvements over the years both strengthening and broadening our product offering. This is evident in the breadth of our line and ability to accommodate new applications and designs. You can count on Behringer for all your clamping and support requirements.

Product

Behringer Hygienic Tube Supports are designed to meet the high demands of process piping in hygienic service applications. The automatic slope adjustment feature of the CH Series Dynamic hanger will promote drainability of the piping without imparting unnecessary stress into the piping. Drainability is a critical design feature in hygienic process piping. Behringer Sanitary Pipe and Tube Supports are available in a wide range of sizes and configurations and are offered with both an anchor or guide insert to meet the needs of any application. Behringer offers many different series and within each series there are many different configurations available. We offer options for mounting such as welding, bolting, rail and strut mounting, double, and group mounting, etc. Behringer always welcomes a challenge, and would be happy to work with you to design a product that is custom-tailored to your application. This is where many of our developments are first generated, and helps to further progress the complexity of our product. Challenge us with your requirements.

Guarantee

Behringer Corporation, hereinafter called the "MANUFACTURER", guarantees that this product shall be free from defects in workmanship and materials. THIS GUARANTEE IS IN LIEU OF ALL OTHER GUARANTEES EITHER EXPRESSED OR IMPLIED, INCLUDING GUARANTEES FOR FITNESS FOR PURPOSE INTENDED. The MANUFACTURER'S liability is limited to the replacement of any materials which, after inspection by the MANUFACTURER at its sole option, are found to be defective. The MANUFACTURER will honor only those claims that are presented to it within one hundred eighty (180) days of the delivery of the materials to the purchaser. The MANUFACTURER SPECIFICALLY DISCLAIMS ANY AND ALL LIABILITY FOR CONSEQUENTIAL DAMAGES. The MANUFACTURER shall not be liable for any damages which arise out of the misuse or abuse of the products.

Applications

Behringer clamps are used in many different types of applications ranging from low pressure lubrication and water systems to high pressure hydraulic and process systems. Anywhere that there are pipes, tubes, or hoses is a viable application for Behringer clamps. Behringer clamps are used in the following markets and applications most frequently:

- Mobile Equipment Power Generation
- Mining Equipment Pulp and Paper
- Offshore and Marine Applications Industrial Hydraulics
- Shipbuilding Power Units
- Instrumentation Agricultural Equipment
- Nuclear OEM Machinery
- General Construction
- Electrical / Mechanical Contracting
- Process Piping
- Pharmaceutical / Biotechnology
- Food and Dairy
- Beverage

Assistance

Behringer Corporation has a competent and highly skilled staff of inside sales and customer service personnel available to assist you with any of your needs. Behringer can be reached in the following ways:

Post Mail:

Behringer Corporation
17 Ridge Road
Branchville, NJ 07826

Telephone:

+1 (973) 948-0226

Fax:

+1 (973) 948-2562

Email:

cserv@behringersystems.com

Our regular business hours are Monday through Friday, 8AM - 5 PM Eastern Time.
For after-hours service, please contact your regional sales manager.

Please Read

The information contained in this document is provided as an aid in properly selecting products and/or options. It is intended to be used by technically experienced users for general reference only. The supplier assumes no responsibility or liability for the accuracy or completeness of this document, as well as results obtained by the use of this information. Due to the variety of possible operating conditions, it is highly recommended that the user make their own tests to determine the safety and suitability of all products and combinations thereof. The user is solely responsible for final determination of such conditions.



CH Series

CH – DYNAMIC MOUNT HANGER..... 6-10
[About](#) | [Part Number Configurator](#) | [Schematic](#) | [Size Chart](#) | [Photos](#)

CHR – RIGID MOUNT HANGER..... 11-15
[About](#) | [Part Number Configurator](#) | [Schematic](#) | [Size Chart](#) | [Photos](#)

CHW – WELD PLATE MOUNT SUPPORT 16-20
[About](#) | [Part Number Configurator](#) | [Schematic](#) | [Size Chart](#) | [Photos](#)

CHT – RIGID THREADED MOUNT HANGER 21-25
[About](#) | [Part Number Configurator](#) | [Schematic](#) | [Size Chart](#) | [Photos](#)

THREADED SUPPORT ROD 26-27
[About](#) | [Part Number Configurator](#) | [Size Chart](#)

TAPERED GUIDES..... 28-29
[About](#) | [Schematic](#) | [Photos](#)



221 CH



221 CHR



221 CHW



221 CHT



245



Tapered Guides



Dynamic Slope Adjusting Hanger/Rod Mount Unit

One piece unit with attached dynamic rod. Hanger rods are available in lengths ranging from min of 1.4" to 96". Standard length is 6".

Features: A dynamic union between the hanger rod and hanger housing allows for the housing to self adjust to the tube's slope for drainability as well as a 360° swivel. A 6" rod is the standard length with other lengths available. Fig 221 CH can also be used in combination with our stanchions and/or height adjusters. This combination will allow the support to be adjusted telescopically to the tube or pipe elevation. Call customer service for the price and availability of special rod lengths.

Size Range: 0.24" diameters through 6.00" diameter covering imperial tube, pipe and copper sizes. ISO and DIN standards, and special diameters available upon request.

Hardware: 304 Stainless Steel (Standard), 316 Stainless Steel

Finish: 25 RA

Plastic: Polyethersulfone (PESU) (Black = Anchor and Gray = Guide)
See technical data for temperature ratings.

Anchors: Refer to shear force diagram in technical section (page 88).

Guides: Allows free axial movement for thermal expansion of tube or pipe

221 CH Compact Dynamic Hanger - Part Number Configurator

Part Number Example:
CH - PS - 150 - T - 06

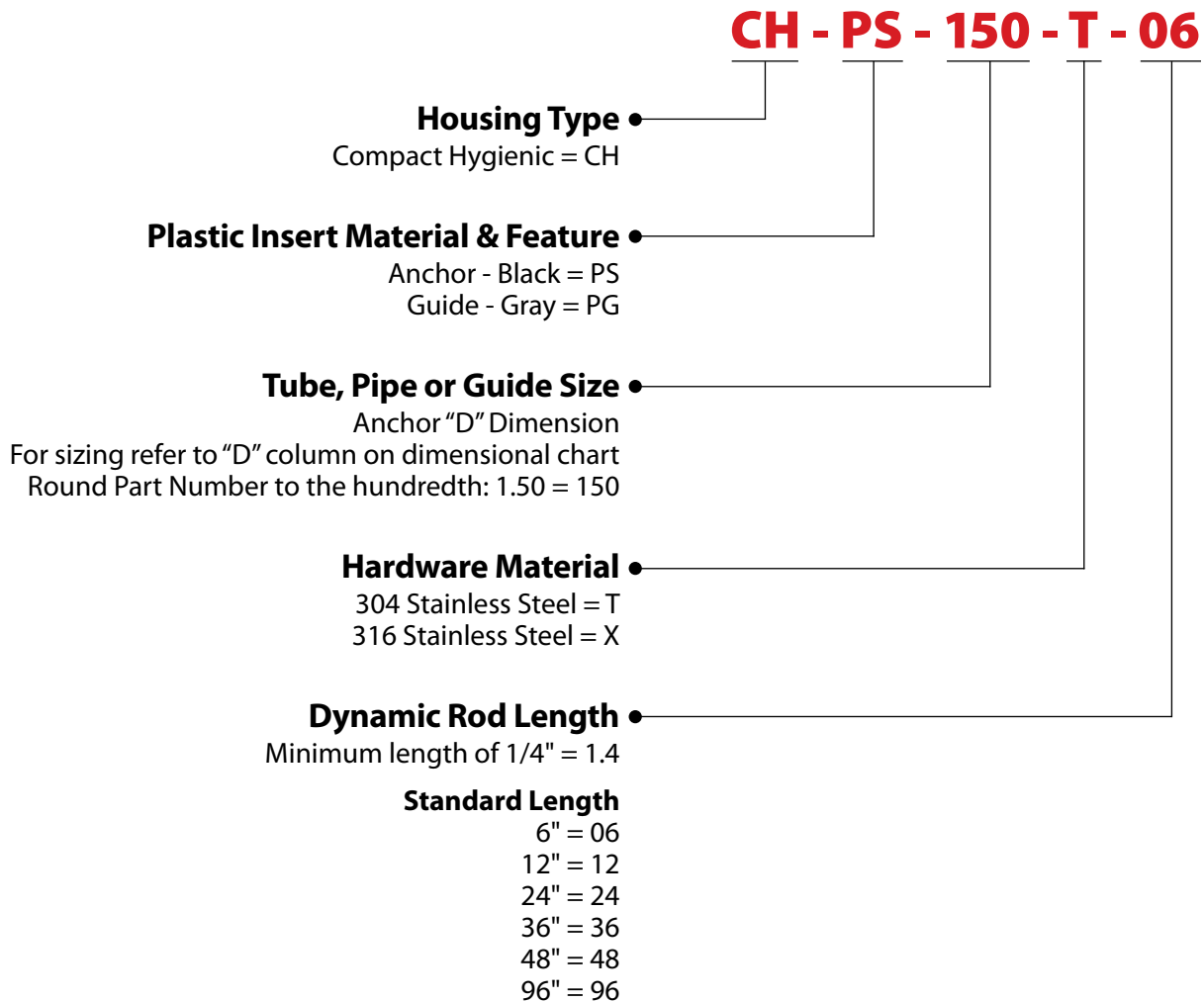

FIG. 221 CH

DYNAMIC MOUNT HANGER

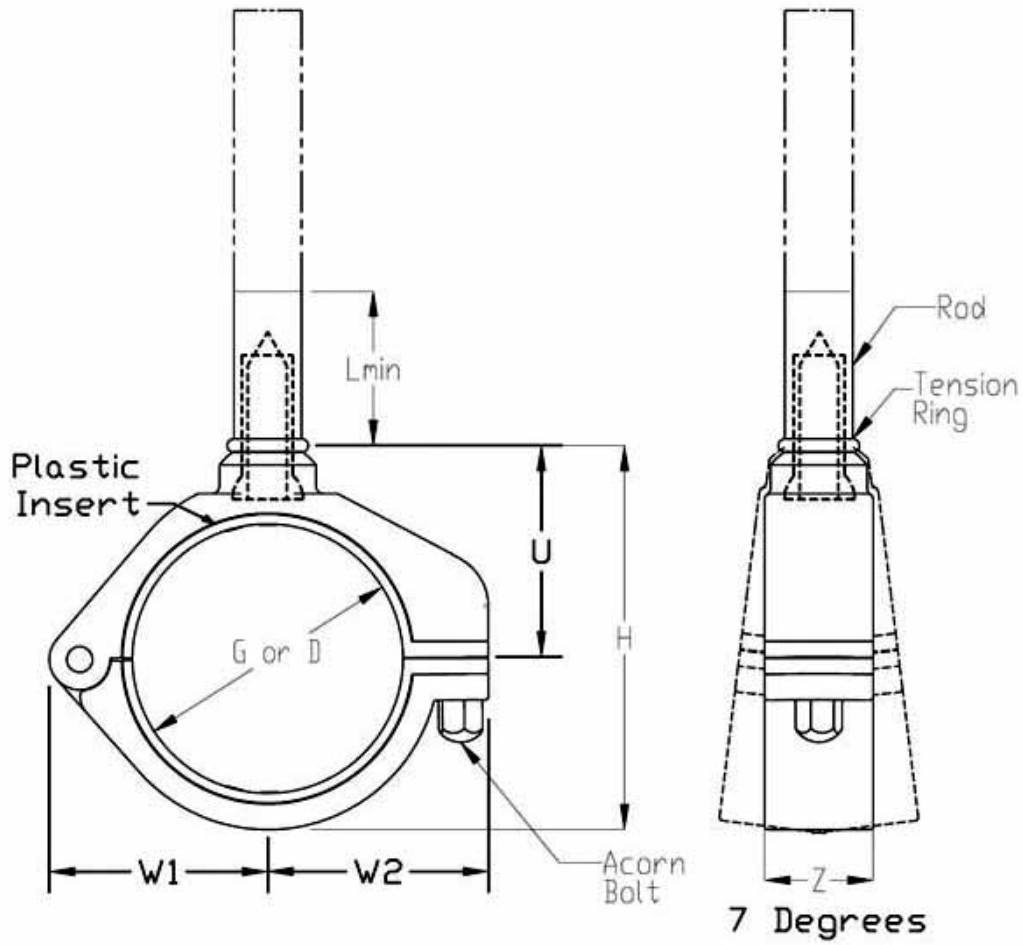

FIG. 221 CH

DYNAMIC MOUNT HANGER

Group No.	Stainless Tube	Pipe	Copper Tube	Outside Diameter (mm)	221 CH	UNIVERSAL DIMENSIONS AMONG HOUSINGS				221 CH						
					Part Number (-PS- as displayed is an Anchor & -PG- would make a Guide)	"D" Anchor Plastic	"G" Guide Plastic	Dimension, in. (mm)							Rod Diameter	Weight, lb (kg)
								W1	W2	Z	L, min	U	H			
1	6 mm			6.0	CH-PS-024-T-??	0.24	0.27	0.93 (24)	1.02 (26)	0.75 (19)	1.26 (32)	0.95 (24)	1.54 (39)	0.63 (16)	0.76 (0.34)	
	1/4"			6.3	CH-PS-025-T-??	0.25	0.29									
	3/8"			9.6	CH-PS-038-T-??	0.38	0.40									
	1/2"			12.7	CH-PS-050-T-??	0.50	0.54									
2		1/4"		13.7	CH-PS-054-T-??	0.54	0.58	1.06 (27)	1.15 (29)	0.75 (19)	1.26 (32)	1.07 (27)	1.77 (45)	0.63 (16)	0.79 (0.36)	
			1/2"	16.0	CH-PS-063-T-??	0.63	0.67									
			3/4"	19.0	CH-PS-075-T-??	0.75	0.79									
3	20 mm			20.0	CH-PS-079-T-??	0.79	0.82	1.20 (31)	1.28 (33)	0.75 (19)	1.26 (32)	1.20 (30)	2.04 (52)	0.63 (16)	0.82 (0.37)	
		1/2"		21.3	CH-PS-084-T-??	0.84	0.88									
			3/4"	22.4	CH-PS-088-T-??	0.88	0.91									
			1"	25.4	CH-PS-100-T-??	1.00	1.04									
4		3/4"		26.7	CH-PS-105-T-??	1.05	1.09	1.45 (37)	1.56 (40)	0.75 (19)	1.26 (32)	1.45 (39)	2.53 (65)	0.63 (16)	0.86 (0.39)	
			1"	28.7	CH-PS-113-T-??	1.13	1.16									
			1"	33.5	CH-PS-132-T-??	1.32	1.35									
			1 1/2"	38.1	CH-PS-150-T-??	1.50	1.54									
5	40 mm			40.0	CH-PS-158-T-??	1.58	1.61	1.74 (44)	1.79 (46)	0.75 (19)	1.26 (32)	1.70 (43)	3.03 (77)	0.63 (16)	0.97 (0.44)	
			1 1/2"	41.4	CH-PS-163-T-??	1.63	1.66									
			1 1/2"	48.3	CH-PS-190-T-??	1.90	1.94									
			2"	50.8	CH-PS-200-T-??	2.00	2.04									
6	52 mm			52.0	CH-PS-205-T-??	2.05	2.10	2.02 (51)	2.04 (52)	1.00 (25)	1.36 (35)	2.04 (52)	3.63 (92)	0.75 (19)	1.37 (0.62)	
			2"	54.0	CH-PS-213-T-??	2.13	2.18									
			2"	60.3	CH-PS-238-T-??	2.38	2.43									
			2 1/2"	63.5	CH-PS-250-T-??	2.50	2.55									
7	70 mm			70.0	CH-PS-276-T-??	2.76	2.81	2.27 (58)	2.29 (58)	1.00 (25)	1.36 (35)	2.29 (58)	4.13 (105)	0.75 (19)	1.42 (0.64)	
			2 1/2"	73.1	CH-PS-288-T-??	2.88	2.93									
			3"	76.1	CH-PS-300-T-??	3.00	3.05									
8			3"	79.5	CH-PS-313-T-??	3.13	3.18	2.76 (70)	2.79 (71)	1.00 (25)	1.36 (35)	2.79 (71)	5.13 (131)	0.75 (19)	1.62 (0.73)	
			3"	88.9	CH-PS-350-T-??	3.50	3.55									
			4"	101.6	CH-PS-400-T-??	4.00	4.05									
8A	104 mm			104.0	CH-PS-409-T-??	4.09	4.14	3.00 (76)	3.09 (78)	1.00 (25)	1.36 (35)	3.04 (77)	5.63 (143)	0.75 (19)	1.72 (0.78)	
			4"	104.9	CH-PS-413-T-??	4.13	4.18									
			4"	114.3	CH-PS-450-T-??	4.50	4.55									
9	129 mm			129.0	CH-PS-508-T-??	5.08	5.13	3.98 (101)	4.46 (113)	1.50 (38)	1.78 (45)	4.16 (106)	7.74 (197)	1.00 (25)	5.33 (2.42)	
			6"	152.4	CH-PS-600-T-??	6.00	6.05									

FIG. 221 CH

DYNAMIC MOUNT HANGER



Housing with Gray inserts are "Guide" supports

Housing with Black inserts are "Anchor" supports





Rigid Hanger/Rod Mount Unit

One piece unit with rod welded to the hanger housing. Hanger rods are available in lengths up to 96". Standard rod length is 6"

Features: The rigid hanger is ideal for supporting vertical runs and reducing vibrations. This type rod connection does not offer the dynamic slope adjustment. 6" rod is the standard length with other lengths available. Fig 221 CHR can also be used in combination with our stanchions and/or height adjusters. This combination will allow the support to be adjusted telescopically to the tube or pipe elevation. Call customer service for the price and availability of special rod lengths.

Size Range: 0.24" diameters through 6.00" diameter covering imperial tube, pipe and copper sizes. ISO and DIN standards, and special diameters available upon request.

Hardware: 304 Stainless Steel (Standard), 316 Stainless Steel

Finish: 25 RA

Plastic: Polyethersulfone (PESU) (Black = Anchor and Gray = Guide). See Technical Data for temperature ratings.

Anchors: Refer to shear force diagram in technical section (page 88)

Guides: Allows free axial movement for thermal expansion of tube or pipe

221 CHR Rigid Mount Hanger - Part Number Configurator

Part Number Example:

CHR - PG - 150 - T - 06

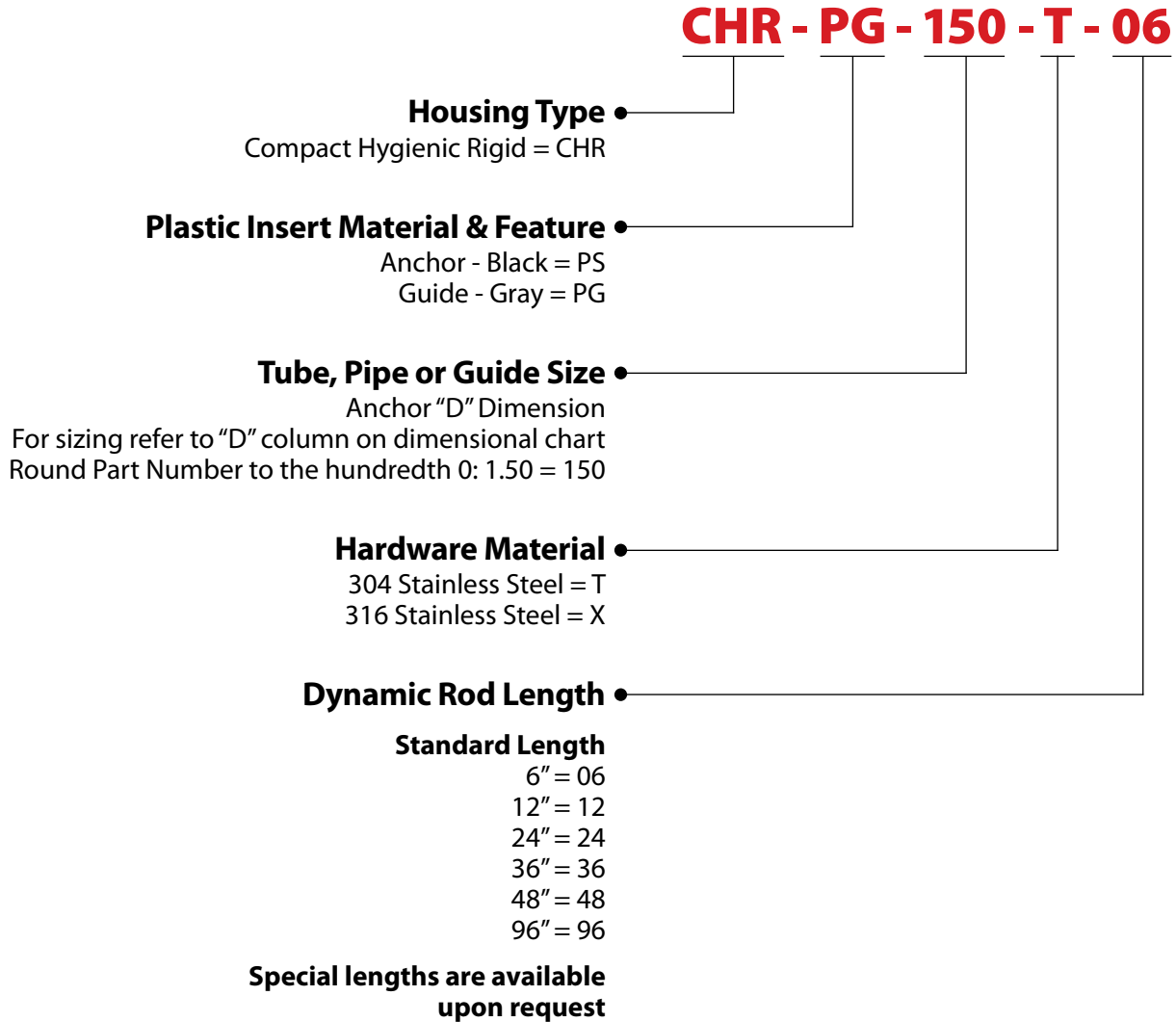

FIG. 221 CHR

RIGID MOUNT HANGER

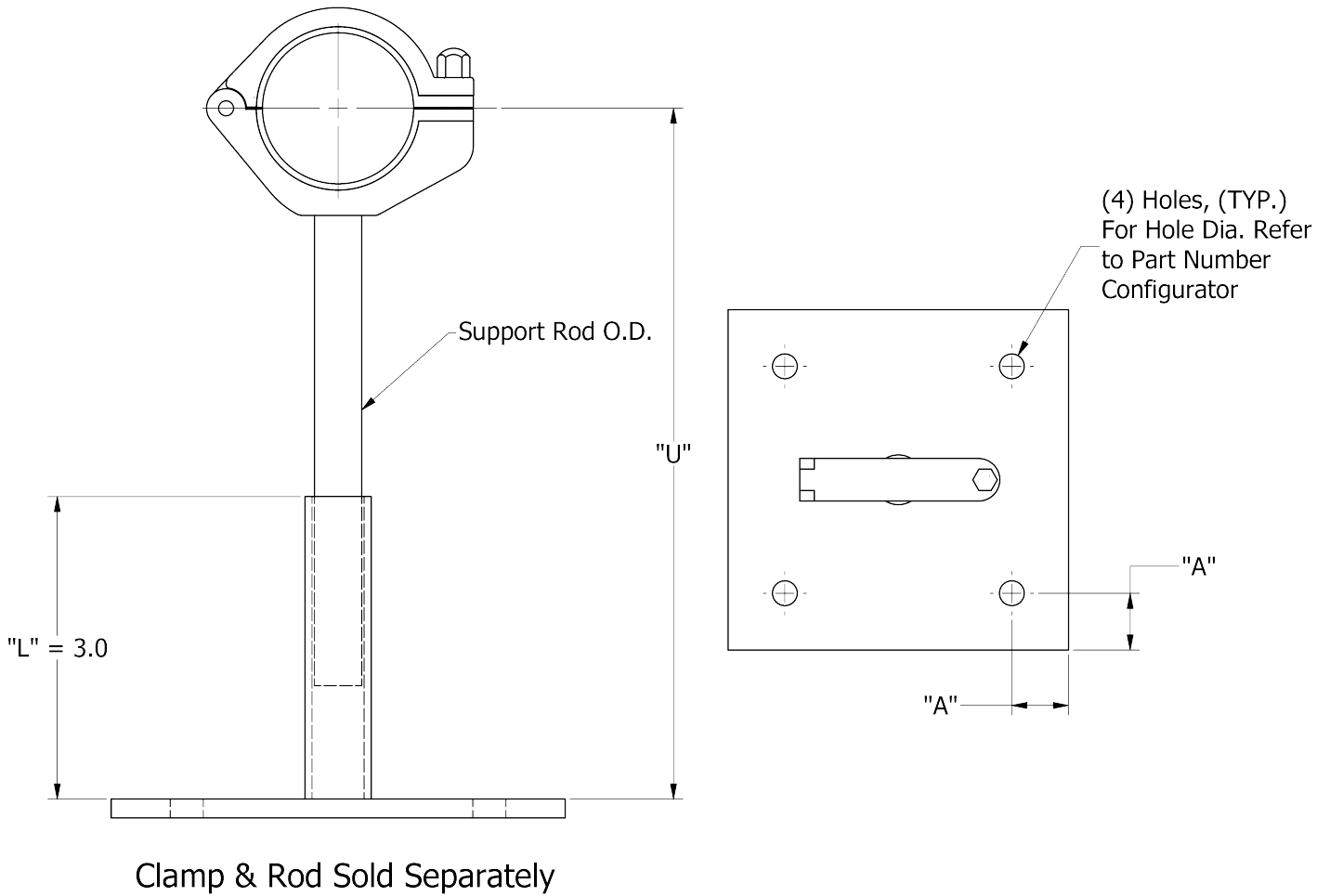

FIG. 221 CHR

RIGID MOUNT HANGER

Group No.	Stainless Tube	Pipe	Copper Tube	Outside Diameter (mm)	221 CHR	UNIVERSAL DIMENSIONS AMONG HOUSINGS				221 CHR						
					Part Number (-PS- as displayed is an Anchor & -PG- would make a Guide)	"D" Anchor Plastic	"G" Guide Plastic	Dimension, in. (mm)							Rod Diameter	Weight, lb (kg)
								W1	W2	Z	U, min	H	L			
1	6 mm			6.0	CHR-PS-024-T-??	0.24	0.27	0.93 (24)	1.02 (26)	0.75 (19)	1.08 (28)	1.67 (42)	??	1/2" (12)	0.58 (0.26)	
	1/4"			6.3	CHR-PS-025-T-??	0.25	0.29									
	3/8"			9.6	CHR-PS-038-T-??	0.38	0.40									
	1/2"			12.7	CHR-PS-050-T-??	0.50	0.54									
2		1/4"		13.7	CHR-PS-054-T-??	0.54	0.58	1.06 (27)	1.15 (29)	0.75 (19)	1.23 (31)	1.93 (49)	??	1/2" (12)	0.60 (0.27)	
			1/2"	16.0	CHR-PS-063-T-??	0.63	0.67									
			3/4"	19.0	CHR-PS-075-T-??	0.75	0.79									
3	20 mm			20.0	CHR-PS-079-T-??	0.79	0.82	1.20 (31)	1.28 (33)	0.75 (19)	1.35 (34)	2.19 (56)	??	1/2" (12)	0.66 (0.30)	
		1/2"		21.3	CHR-PS-084-T-??	0.84	0.88									
			3/4"	22.4	CHR-PS-088-T-??	0.88	0.91									
			1"	25.4	CHR-PS-100-T-??	1.00	1.04									
4		3/4"		26.7	CHR-PS-105-T-??	1.05	1.09	1.45 (37)	1.56 (40)	0.75 (19)	1.66 (42)	2.74 (69)	??	1/2" (12)	0.72 (0.33)	
			1"	28.7	CHR-PS-113-T-??	1.13	1.16									
			1"	33.5	CHR-PS-132-T-??	1.32	1.35									
			1 1/2"	38.1	CHR-PS-150-T-??	1.50	1.54									
5	40 mm			40.0	CHR-PS-158-T-??	1.58	1.61	1.74 (44)	1.79 (46)	0.75 (19)	1.85 (47)	3.18 (81)	??	1/2" (12)	0.80 (0.36)	
			1 1/2"	41.4	CHR-PS-163-T-??	1.63	1.66									
		1 1/2"		48.3	CHR-PS-190-T-??	1.90	1.94									
			2"	50.8	CHR-PS-200-T-??	2.00	2.04									
6	52 mm			52.0	CHR-PS-205-T-??	2.05	2.10	2.02 (51)	2.04 (52)	1.00 (25)	2.18 (55)	3.77 (96)	??	5/8" (16)	1.61 (0.73)	
			2"	54.0	CHR-PS-213-T-??	2.13	2.18									
		2"		60.3	CHR-PS-238-T-??	2.38	2.43									
			2 1/2"	63.5	CHR-PS-250-T-??	2.50	2.55									
7	70 mm			70.0	CHR-PS-276-T-??	2.76	2.81	2.27 (58)	2.29 (58)	1.00 (25)	2.34 (59)	4.18 (106)	??	5/8" (16)	1.67 (0.73)	
			2 1/2"	73.1	CHR-PS-288-T-??	2.88	2.93									
			3"	76.1	CHR-PS-300-T-??	3.00	3.05									
8			3"	79.5	CHR-PS-313-T-??	3.13	3.18	2.76 (70)	2.79 (71)	1.00 (25)	3.08 (78)	5.42 (137)	??	3/4" (19)	1.86 (0.84)	
			3"	88.9	CHR-PS-350-T-??	3.50	3.55									
			4"	101.6	CHR-PS-400-T-??	4.00	4.05									
8A	104 mm			104.0	CHR-PS-409-T-??	4.09	4.14	3.01 (76)	3.09 (78)	1.00 (25)	3.28 (83)	5.87 (149)	??	3/4" (19)	1.88 (0.85)	
			4"	104.9	CHR-PS-413-T-??	4.13	4.18									
			4"	114.3	CHR-PS-450-T-??	4.50	4.55									
9	129 mm			129.0	CHR-PS-508-T-??	5.08	5.13	3.98 (101)	4.46 (113)	1.50 (38)	4.45 (113)	8.03 (204)	??	1" (25)	6.21 (2.81)	
			6"	152.4	CHR-PS-600-T-??	6.00	6.05									

All standard sizes shown, special diameters available upon request.

FIG. 221 CHR

RIGID MOUNT HANGER





Rigid Support with Weld Plate

One piece unit with weld plate attached to hanger housing.

Features: Compact housing is mounted on a weld plate. The CHW hanger is ideal for supporting vertical runs, as a short offset base sliding support or to reduce vibration.

Size Range: 0.24" diameters through 6.00" diameter covering imperial tube, pipe and copper sizes. ISO and DIN standards and special diameters available upon request.

Hardware: 304 Stainless Steel (Standard), 316 Stainless Steel

Finish: 25 RA

Plastic: Polyethersulfone (PESU) (Black = Anchor and Gray = Guide). See Technical Data for temperature ratings.

Anchors: Refer to shear force diagram in technical section (page 88).

Guides: Allows free axial movement for thermal expansion of tube or pipe

221 CHW Weld Plate Mount Support - Part Number Configurator

Part Number Example:

CHW - PS - 200 - T

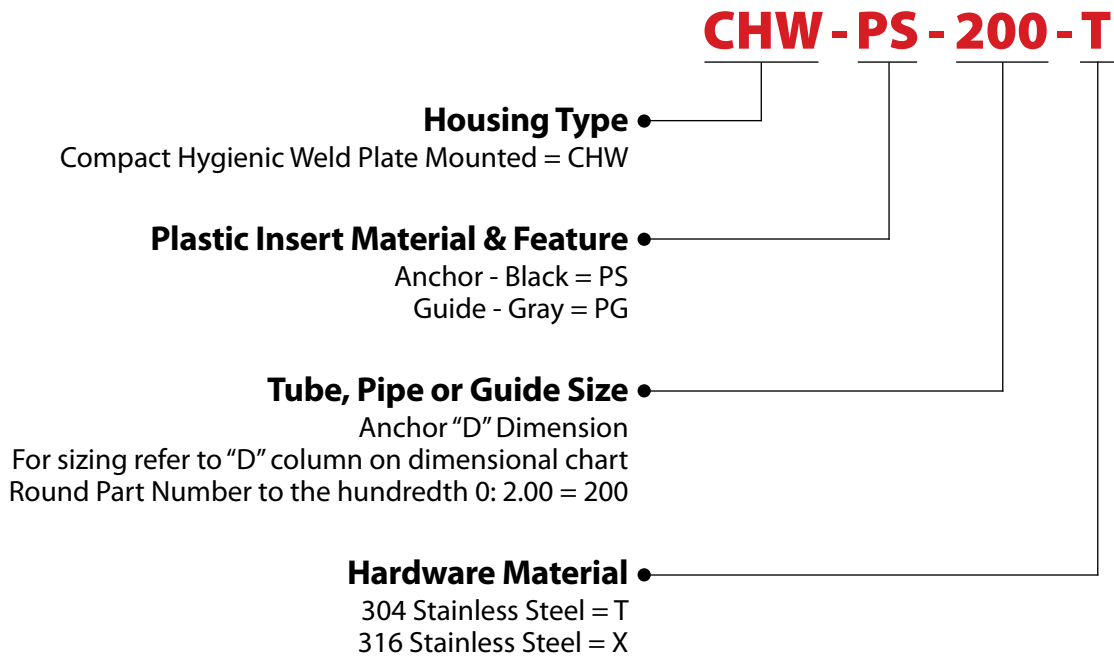

FIG. 221 CHW

WELD PLATE MOUNT SUPPORT

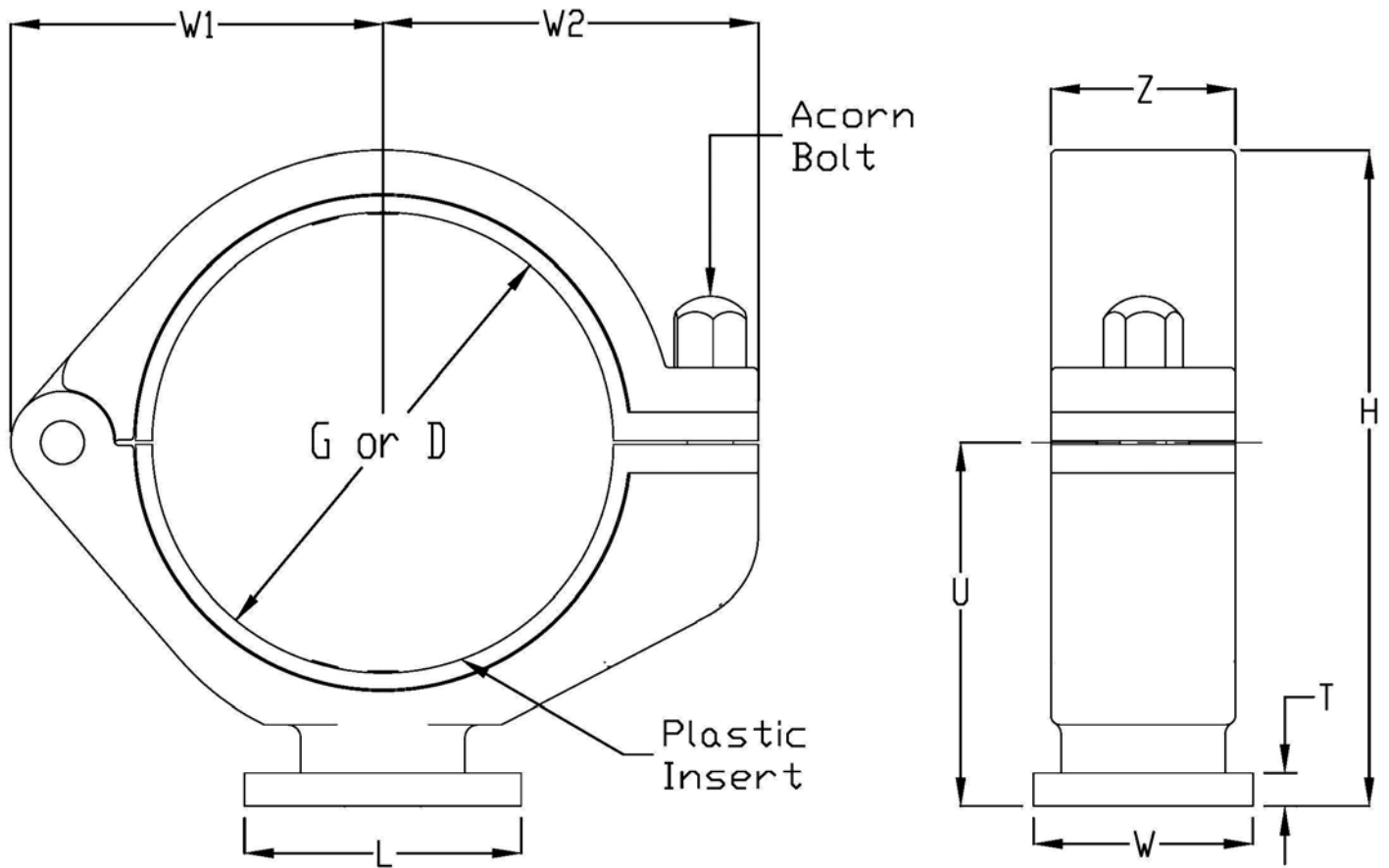

FIG. 221 CHW

WELD PLATE MOUNT SUPPORT

Group No.	Stainless Tube	Pipe	Copper Tube	Outside Diameter (mm)	221 CHW	UNIVERSAL DIMENSIONS AMONG HOUSINGS				221 CHW				Weight, lb (kg)		
					Part Number (-PS- as displayed is an Anchor & -PG- would make a Guide)	"D" Anchor Plastic	"G" Guide Plastic	Dimension, in. (mm)								
								W1	W2	Z	U	H	T		L	W
1	6 mm			6.0	CHW-PS-024-T	0.24	0.27	0.93 (24)	1.02 (26)	0.75 (19)	1.17 (30)	1.76 (45)	3/16" (4.7)	1.50 (38)	1.50 (38)	0.37 (0.17)
	1/4"			6.3	CHW-PS-025-T	0.25	0.29									
	3/8"			9.6	CHW-PS-038-T	0.38	0.40									
	1/2"			12.7	CHW-PS-050-T	0.50	0.54									
2		1/4"		13.7	CHW-PS-054-T	0.54	0.58	1.06 (27)	1.15 (29)	0.75 (19)	1.32 (33)	2.02 (51)	3/16" (4.7)	1.50 (38)	1.50 (38)	0.39 (0.18)
			1/2"	16.0	CHW-PS-063-T	0.63	0.67									
			3/4"	19.0	CHW-PS-075-T	0.75	0.79									
3	20 mm			20.0	CHW-PS-079-T	0.79	0.82	1.20 (31)	1.28 (33)	0.75 (19)	1.44 (37)	2.28 (58)	3/16" (4.7)	1.50 (38)	1.50 (38)	0.44 (0.20)
		1/2"		21.3	CHW-PS-084-T	0.84	0.88									
			3/4"	22.4	CHW-PS-088-T	0.88	0.91									
			1"	25.4	CHW-PS-100-T	1.00	1.04									
4		3/4"		26.7	CHW-PS-105-T	1.05	1.09	1.45 (37)	1.56 (39)	0.75 (19)	1.75 (44)	2.83 (72)	3/16" (4.7)	1.75 (44)	1.75 (44)	0.56 (0.25)
			1"	28.7	CHW-PS-113-T	1.13	1.16									
		1"		33.5	CHW-PS-132-T	1.32	1.35									
			1 1/2"	38.1	CHW-PS-150-T	1.50	1.54									
5	40 mm			40.0	CHW-PS-158-T	1.58	1.61	1.74 (44)	1.79 (46)	0.75 (19)	1.94 (49)	3.27 (83)	3/16" (4.7)	1.75 (44)	1.75 (44)	0.63 (0.28)
			1 1/2"	41.4	CHW-PS-163-T	1.63	1.66									
		1 1/2"		48.3	CHW-PS-190-T	1.90	1.94									
			2"	50.8	CHW-PS-200-T	2.00	2.04									
6	52 mm			52.0	CHW-PS-205-T	2.05	2.10	2.02 (51)	2.04 (52)	1.00 (25)	2.27 (58)	3.86 (98)	3/16" (4.7)	2.50 (64)	1.75 (44)	0.90 (0.41)
			2"	54.0	CHW-PS-213-T	2.13	2.18									
		2"		60.3	CHW-PS-238-T	2.38	2.43									
			2 1/2"	63.5	CHW-PS-250-T	2.50	2.55									
7	70 mm			70.0	CHW-PS-276-T	2.76	2.81	2.27 (58)	2.29 (58)	1.00 (25)	2.43 (62)	4.27 (108)	3/16" (4.7)	2.50 (64)	1.75 (44)	0.96 (0.43)
		2 1/2"		73.1	CHW-PS-288-T	2.88	2.93									
			3"	76.1	CHW-PS-300-T	3.00	3.05									
8			3"	79.5	CHW-PS-313-T	3.13	3.18	2.76 (70)	2.79 (71)	1.00 (25)	3.17 (81)	5.51 (140)	3/16" (4.7)	2.50 (64)	1.75 (44)	1.15 (0.52)
		3"		88.9	CHW-PS-350-T	3.50	3.55									
		4"		101.6	CHW-PS-400-T	4.00	4.05									
8A	104 mm			104.0	CHW-PS-409-T	4.09	4.14	3.00 (76)	3.09 (78)	1.00 (25.4)	3.37 (86)	5.96 (151)	3/16" (4.7)	2.50 (64)	1.75 (44)	1.17 (0.53)
			4"	104.9	CHW-PS-413-T	4.13	4.18									
		4"		114.3	CHW-PS-450-T	4.50	4.55									
9	129 mm			129.0	CHW-PS-508-T	5.08	5.13	3.98 (101)	4.46 (113)	1.50 (38)	4.54 (115)	8.12 (206)	1/4" (6.4)	4.00 (108)	1.75 (44)	4.67 (2.12)
		6"		152.4	CHW-PS-600-T	6.00	6.05									

All standard sizes shown, special diameters available upon request

FIG. 221 CHW

WELD PLATE MOUNT SUPPORT



FIG. 221 CHT

THREADED MOUNT HANGER



Threaded Anchor or Guide Hanger

One piece unit with threaded adaptor. Rod is sold separately.

Features: The threaded mounting section, on top of housing, doubles as a threaded rod connector and a welding platform. Figure 221 CHT, paired with a Figure 245 rod, can also be used in combination with our stanchions and/or height adjusters. This combination will allow the support to be adjusted telescopically to the tube or pipe elevation. Call customer service for the price and availability of special rod lengths.

Size Range: 0.24" diameters through 8.63" diameter covering imperial tube, pipe and copper sizes. ISO and DIN standards and special diameters available upon request.

Hardware: 304 Stainless Steel (Standard), 316 Stainless Steel

Finish: 25 RA

Plastic: Polyethersulfone (PESU) (Black = Anchor and Gray = Guide). See Technical Data for temperature ratings.

Anchors: Refer to shear force diagram in technical section (page 88).

Guides: Allows free axial movement for thermal expansion of tube or pipe

221 CHT Compact Threaded Mount Hanger - Part Number Configurator

Part Number Example:

CHT - PG - 150 - T

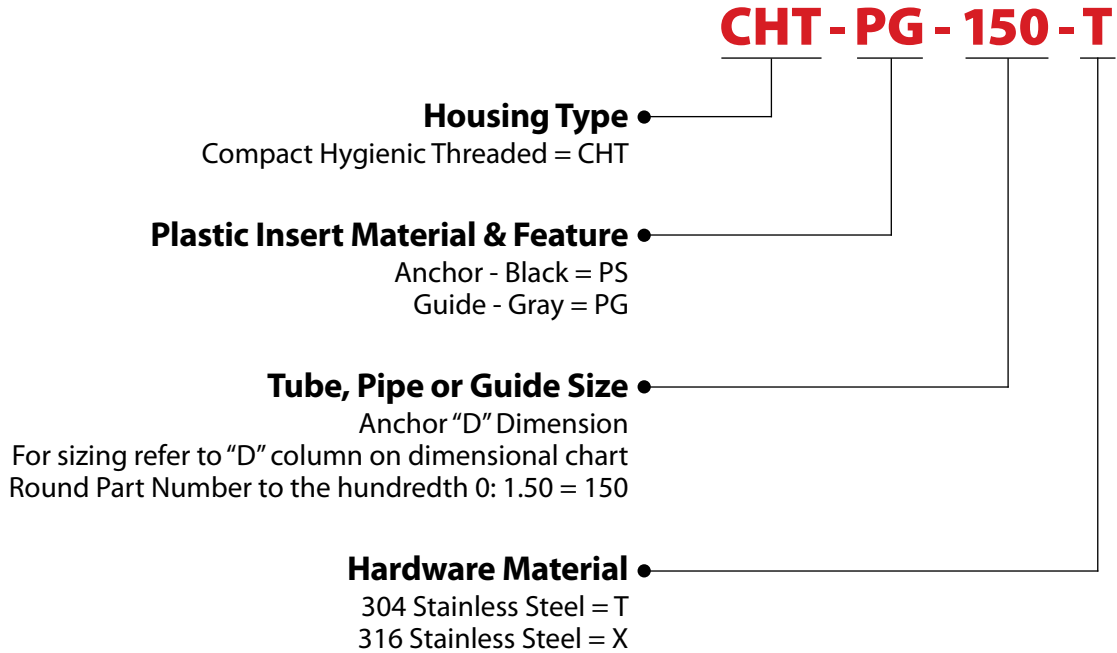

FIG. 221 CHT

THREADED MOUNT HANGER

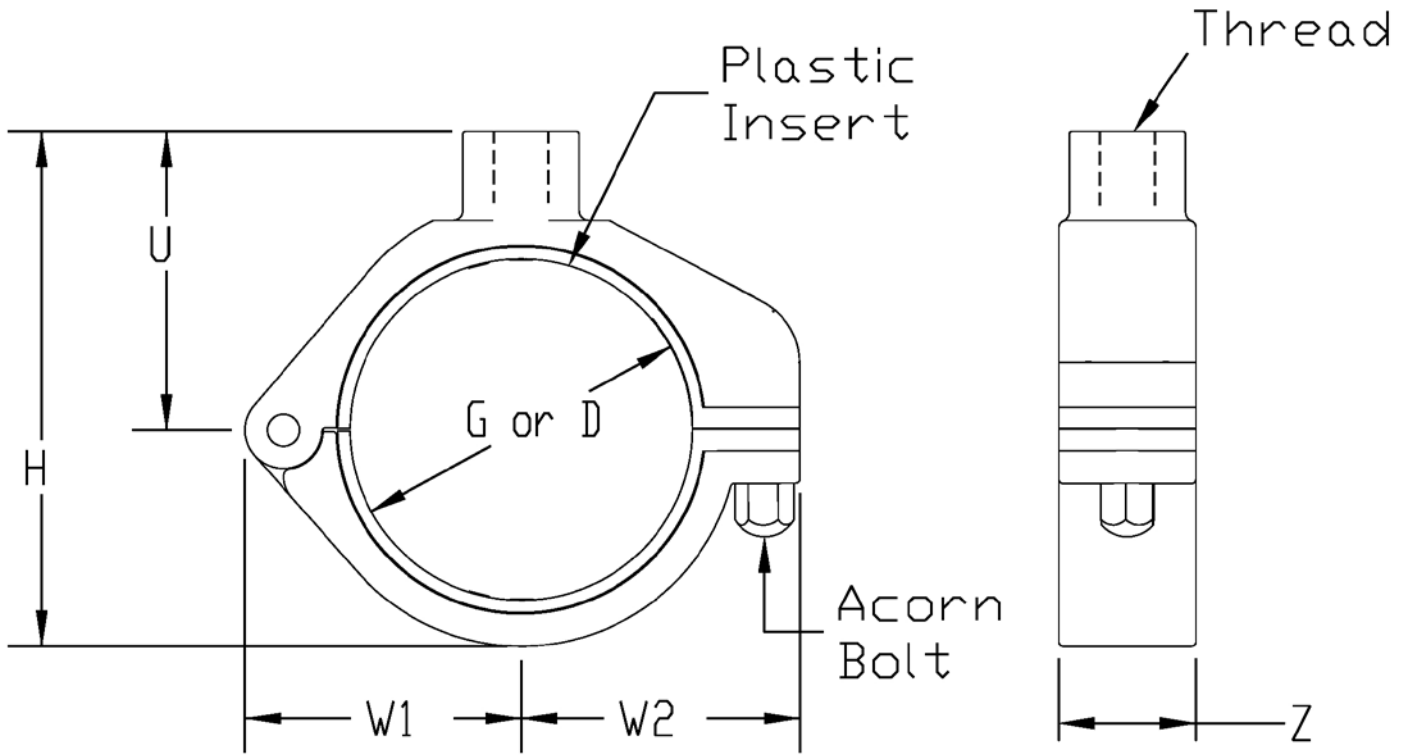

FIG. 221 CHT

THREADED MOUNT HANGER

Group No.	Stainless Tube	Pipe	Copper Tube	Outside Diameter (mm)	221 CHT	UNIVERSAL DIMENSIONS AMONG HOUSINGS			221 CHT						
					Part Number (-PS- as displayed is an Anchor & -PG- would make a Guide)	"D" Anchor Plastic	"G" Guide Plastic	Dimension, in. (mm)						Rod Diameter (Sold Separately)	Weight, lb (kg)
								W1	W2	Z	U	H	Thread		
1	6 mm			6.0	CHT-PS-024-T	0.24	0.27	0.93 (24)	1.02 (26)	0.75 (19)	1.08 (28)	1.67 (42)	3/8"-16 (10)	1/2" (12) B	0.26 (0.12)
	1/4"			6.3	CHT-PS-025-T	0.25	0.29								
	3/8"			9.6	CHT-PS-038-T	0.38	0.40								
	1/2"			12.7	CHT-PS-050-T	0.50	0.54								
2		1/4"		13.7	CHT-PS-054-T	0.54	0.58	1.06 (27)	1.15 (29)	0.75 (19)	1.23 (31)	1.93 (49)	3/8"-16 (10)	1/2" (12) B	0.60 (0.27)
			1/2"	16.0	CHT-PS-063-T	0.63	0.67								
			3/4"	19.0	CHT-PS-075-T	0.75	0.79								
3	20 mm			20.0	CHT-PS-079-T	0.79	0.82	1.20 (31)	1.28 (33)	0.75 (19)	1.35 (34)	2.19 (56)	3/8"-16 (10)	1/2" (12) B	0.33 (0.15)
		1/2"		21.3	CHT-PS-084-T	0.84	0.88								
			3/4"	22.4	CHT-PS-088-T	0.88	0.91								
			1"	25.4	CHT-PS-100-T	1.00	1.04								
4		3/4"		26.7	CHT-PS-105-T	1.05	1.09	1.46 (37)	1.56 (40)	0.75 (19)	1.66 (42)	2.74 (69)	3/8"-16 (10)	1/2" (12) B	0.40 (0.18)
			1"	28.7	CHT-PS-113-T	1.13	1.16								
		1"		33.5	CHT-PS-132-T	1.32	1.35								
			1 1/2"	38.1	CHT-PS-150-T	1.50	1.54								
5	40 mm			40.0	CHT-PS-158-T	1.58	1.61	1.74 (44)	1.79 (46)	0.75 (19)	1.85 (47)	3.18 (81)	3/8"-16 (10)	1/2" (12) B	0.48 (0.22)
			1 1/2"	41.4	CHT-PS-163-T	1.63	1.66								
		1 1/2"		48.3	CHT-PS-190-T	1.90	1.94								
			2"	50.8	CHT-PS-200-T	2.00	2.04								
6	52 mm			52.0	CHT-PS-205-T	2.05	2.10	2.02 (51)	2.04 (52)	1.00 (25)	2.18 (55)	3.77 (96)	3/8"-16 (10)	5/8" (16) C	0.70 (0.32)
			2"	54.0	CHT-PS-213-T	2.13	2.18								
		2"		60.3	CHT-PS-238-T	2.38	2.43								
			2 1/2"	63.5	CHT-PS-250-T	2.50	2.55								
7	70 mm			70.0	CHT-PS-276-T	2.76	2.81	2.27 (58)	2.29 (58)	1.00 (25)	2.34 (59)	4.18 (106)	3/8"-16 (10)	5/8" (16) C	0.76 (0.34)
		2 1/2"		73.1	CHT-PS-288-T	2.88	2.93								
			3"	76.1	CHT-PS-300-T	3.00	3.05								
8			3"	79.5	CHT-PS-313-T	3.13	3.18	2.76 (70)	2.79 (71)	1.00 (25)	3.08 (78)	5.42 (137)	1/2"-13 (12)	3/4" (19) D	0.95 (0.43)
		3"		88.9	CHT-PS-350-T	3.50	3.55								
			4"	101.6	CHT-PS-400-T	4.00	4.05								
8A	104 mm			104.0	CHT-PS-409-T	4.09	4.14	3.00 (76)	3.09 (78)	1.00 (25.4)	3.28 (83)	5.87 (149)	1/2"-13 (12)	3/4" (19) D	0.97 (0.44)
			4"	104.9	CHT-PS-413-T	4.13	4.18								
		4"		114.3	CHT-PS-450-T	4.50	4.55								
9	129 mm			129.0	CHT-PS-508-T	5.08	5.13	3.98 (101)	4.46 (113)	1.50 (38)	4.46 (113)	8.04 (204)	3/4"-10 (19)	1" (25) E	4.20 (1.91)
		6"		152.4	CHT-PS-600-T	6.00	6.05								
10		6"		168.4	CHT-PS-663-X	6.63	6.70	4.13 (105)	4.77 (121)	1.50 (38)	4.79 (122)	8.71 (221)	3/4"-10 (19)	1" (25) E	5.00 (2.26)
11	8"			203.2	CHT-PS-800-X	8.00	8.07	5.14 (130)	5.93 (151)	1.50 (38)	5.87 (149)	10.85 (276)	3/4"-10 (19)	1" (25) E	7.10 (3.22)
		8"		219.2	CHT-PS-863-X	8.63	8.70								

FIG. 221 CHT

THREADED MOUNT HANGER



FIG. 245

THREADED SUPPORT ROD



Threaded Support Rod

Size Range: 3/8" outside diameter to 1" outside diameter with different rod lengths and connection threads available.

Hardware: 304 Stainless Steel or 316 Stainless Steel; Carbon or Electro-Zinc Plated Carbon Steel

Finish: 25 RA

Ordering: To identify the proper thread refer to the "T" column on Fig. 221CHT or the Hang Nut column on Fig. 201. Then use the Fig 245 part number configurator located on page 27.

Installations: Thread the rod into housing. Cut the rod in the field to proper length. Field weld the rod to support structure. The rod can also be used in combination with one of our stanchion assemblies. This combination will allow the support to be adjusted telescopically to the tube or pipe elevation.

245 Threaded Support Rod - Part Number Configurator

Part Number Example:

ROD - 038 - T - B - 25 - 06

ROD - 038 - T - B - 25 - 06

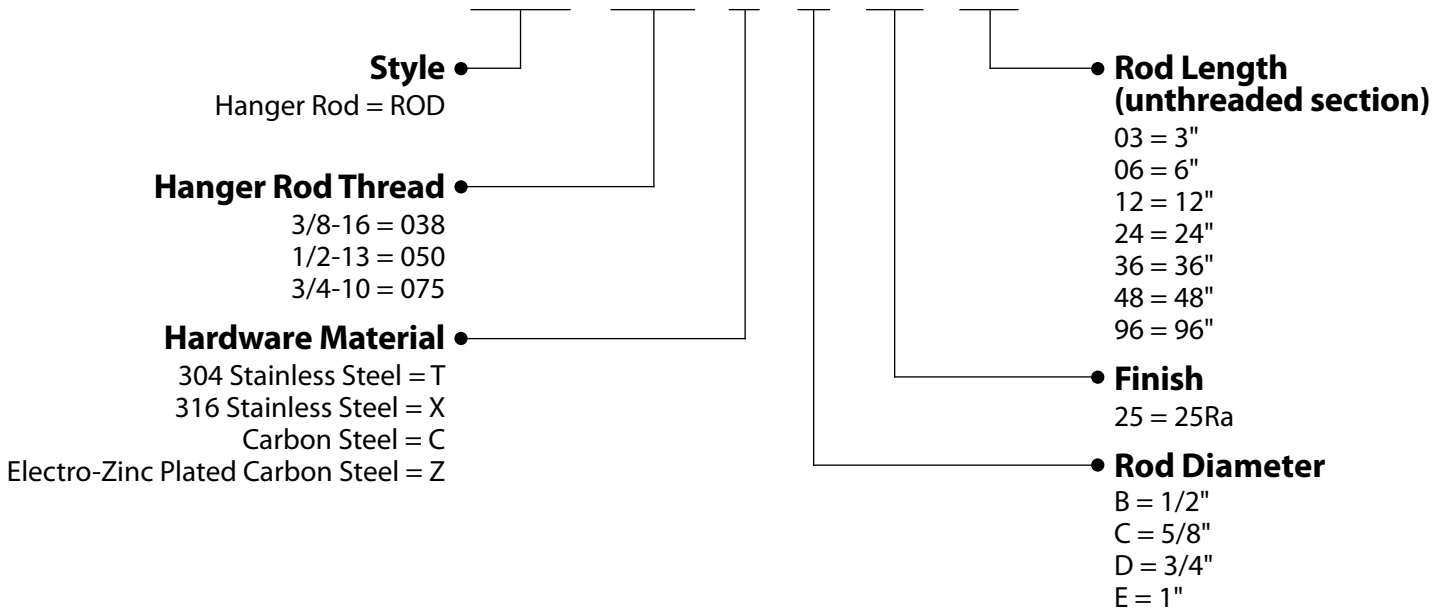

CH Series		SB or Block Style	
Fig. 221CHT		Fig. 201	
OD	Thread	OD	Thread
0.24" to 2.00"	3/8" - 16 (038)	0.25" to 4.5"	3/8"-16 (038)
2.05" to 3.00"	3/8" - 16 (038)	N/A	N/A
3.13" to 4.50"	1/2" - 13 (050)	6.00" to 6.625"	5/8"-11 (063)
5.08" to 6.00"	3/4" - 10 (075)	N/A	N/A



Tapered Guides

- PESU Material-Suitable to 204° C.
- Will accommodate sloped lines without getting caught up in the CH housing.
- Safety yellow color for ease of identification.
- Center landing bore is same as standard guides.
- Available for tube sizes (1/2" to 4").
- Will allow use of rigid CH housings on sloped lines.
- Angle of taper 3 to 5 degrees.

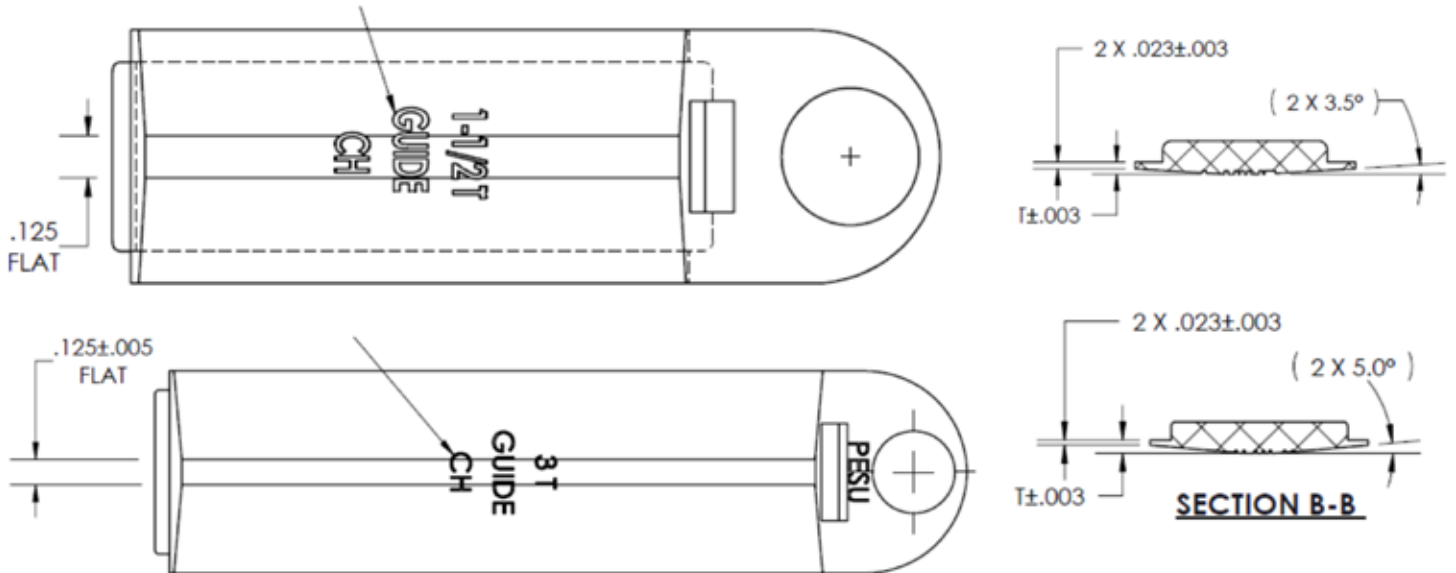

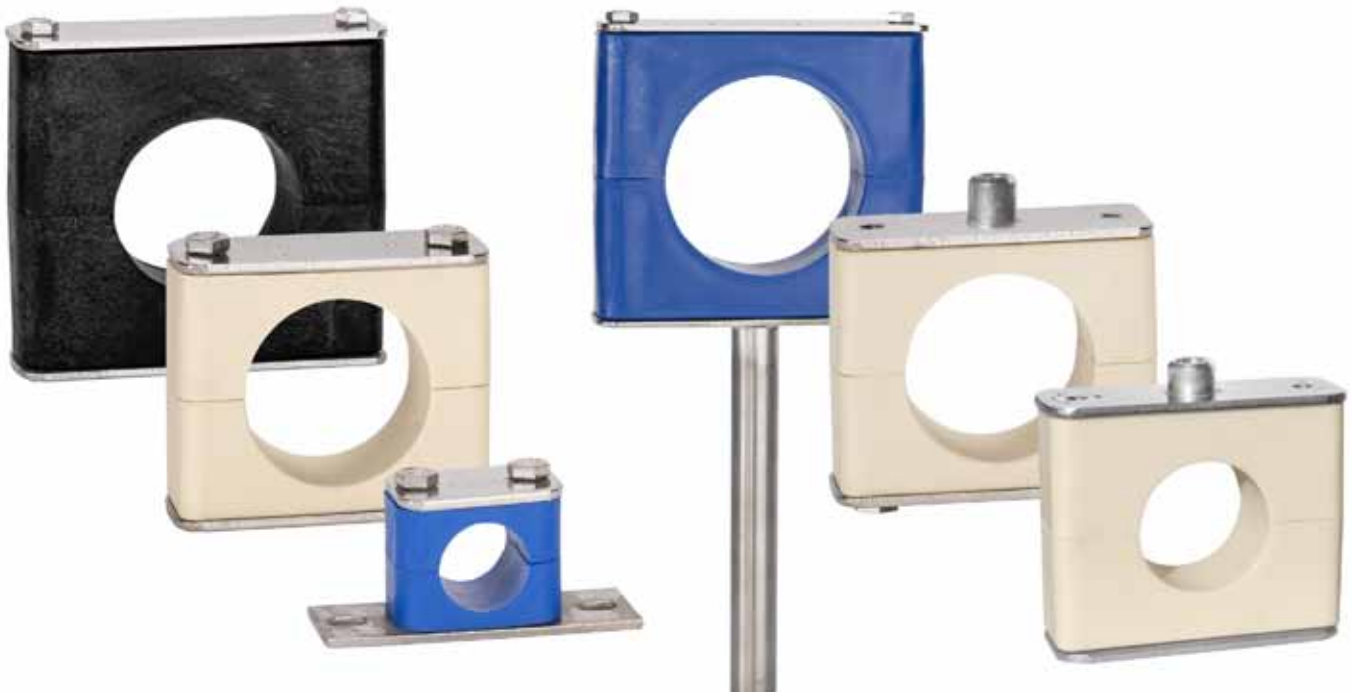

Smooth Bore Series

Mounting / Hardware Configuration 31-32

Fig. 200 Weld Plate Mount 33-37
 About | Part Number Configurator | Schematic | Size Chart | Photos

Fig. 201 Hang Plate Mount 38-42
 About | Part Number Configurator | Schematic | Size Chart | Photos

Fig. 202 Base Plate Mount 43-47
 About | Part Number Configurator | Schematic | Size Chart | Photos

Fig. 203 RAL-1 Rail Mounting 48-49
 About | Part Number Configurator | Schematic

Fig. 204 Stacking Kit 50-54
 About | Part Number Configurator | Schematic | Size Chart | Photos

Fig. 211 Unistrut Mount 55-59
 About | Part Number Configurator | Schematic | Size Chart | Photos

Fig. 221 Rod Mount 60-63
 About | Part Number Configurator | Schematic | Size Chart

Mounting / Hardware Configuration

Behringer offers an array of mounting configurations and arrangement styles for the Sanitary Smooth Bore Series supports. They can be mounted to the support structure by either welding, bolting, hanging, rail mount, strut mount or via stanchions. In addition, they can be stacked on top of each other to save on space.

Please check the ordering code for available assemblies with the configuration you desire. Here are some examples of the mounting options.



Weld Mounting [STW]

Clamps are supplied with a weld plate (STW) for welding directly to the support structure. This is the most commonly used style and includes a cover plate (COP) and hex bolts (HEX).



Hang Mounting [HAP]

Clamps are supplied with a hang plate (HAP) that allows the support block to be installed at a distance from the structural member from which it is mounted. They are hung from threaded rod to the desired elevation.



Bolt Mounting [BAP]

Clamps are supplied with a Base Plate (BAP) for applications where the clamp cannot be welded into position. This is commonly used to mount to non-metallic surfaces, such as wood or drywall.



Rail Mounting [RCN, RAL]

Rail mounting makes installations of multiple lines of different group sizes an easy task. All clamps within one series can be mounted directly to a single channel using Rail Nuts (RCN) or Weld Plates (STW) in conjunction with Behringer's proprietary Mounting Rail (RAL-1).



Strut Mounting [UCN]

Clamps are supplied with Unistrut Clip Nuts (UCN) for mounting to standard Unistrut channel. The nuts adapt to any strut channel that is 1-5/8" wide. The depth of the channel is not important as the UCN clips attach with spring loaded tension to the top of the channel.



Stacking Kits [SKSB]

Stacking kits consist of a set of Clamp Halves (CLH), Stacking Bolts (STB) and a Safety Plate (SAF). A stacking kit is everything needed to take an existing clamp and add an additional level. Start by simply using the hardware from the existing clamp, remove the cover plate, clamp halves, and hex bolts and insert the stacking kit onto the bottom plate and then replace the original hardware on top. Multiple stacking kits can be added to increase the number of clamps stacked in a series.

**Figure 200
Weld Plate Mount**

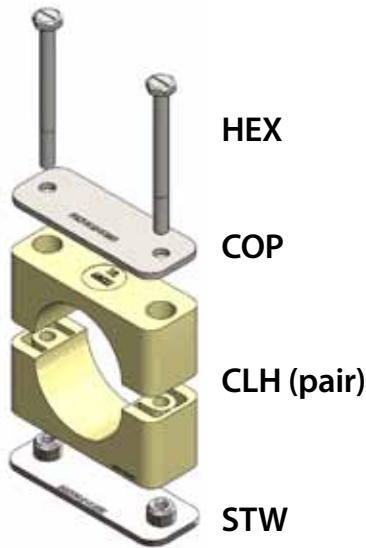

**Figure 202
Base Plate Mount**

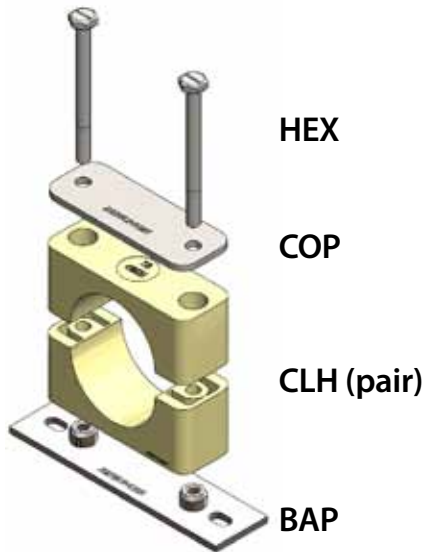

**Figure 211
Unistrut Mount**

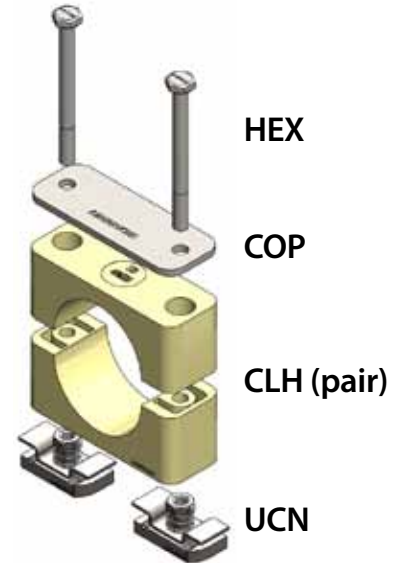

**Figure 201
Hang Plate Mount**

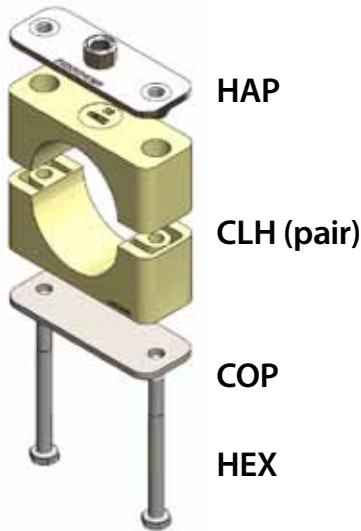

Rail Mount

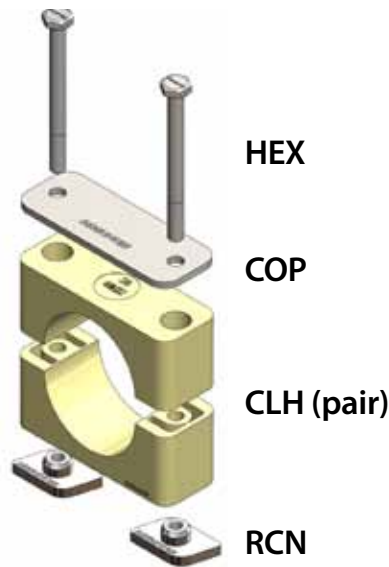

**Figure 204
Stacking Kit**

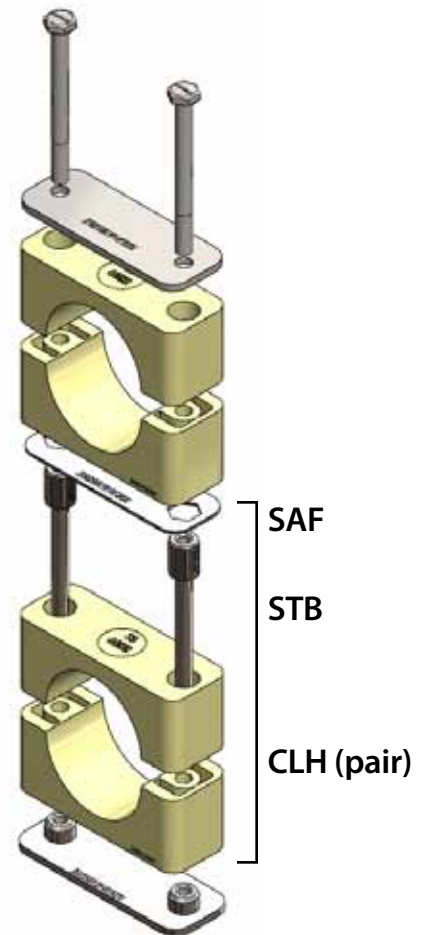

KEY:

BAP - Base Plate	SAF - Safety Plate
CLH - Clamp Half (pair)	STB - Stacking Bolt
COP - Cover Plate	STW- Standard Weld Plate
HAP - Hang Plate	UCN- Unistrut Clip Nut
HEX - Hex Bolt	RCN- Rail Nut

FIG. 200

SMOOTH BORE WELD PLATE MOUNT



Smooth Bore Weld Plate Mount

Size Range: 1/4" outside diameter through 8.625" outside diameter

Hardware: 304 Stainless Steel, 316 Stainless Steel, or Electro-Zinc Plated Carbon Steel

Plastic Inserts: Polypropylene (blue)
Santoprene (beige)
Polyethersulfone (black)
HDPE (white)
High Temp Nylon (black)
*See page 85 for temperature ratings

Installations: Weld bottom plate to structure or supporting member, let cool before mounting plastic blocks.

Thermal Expansion Guide: (Optional) Provides for axial expansion of the tube or pipe due to thermal expansion. One set of two per clamp (See Fig. 207 in accessories)

Thermal Expansion Guide Material: Santoprene, 1/16" insert, Black for service identification

200 Smooth Bore Weld Plate Mount - Part Number Configurator

Part Number Example:

SB T 7 2375 - PP

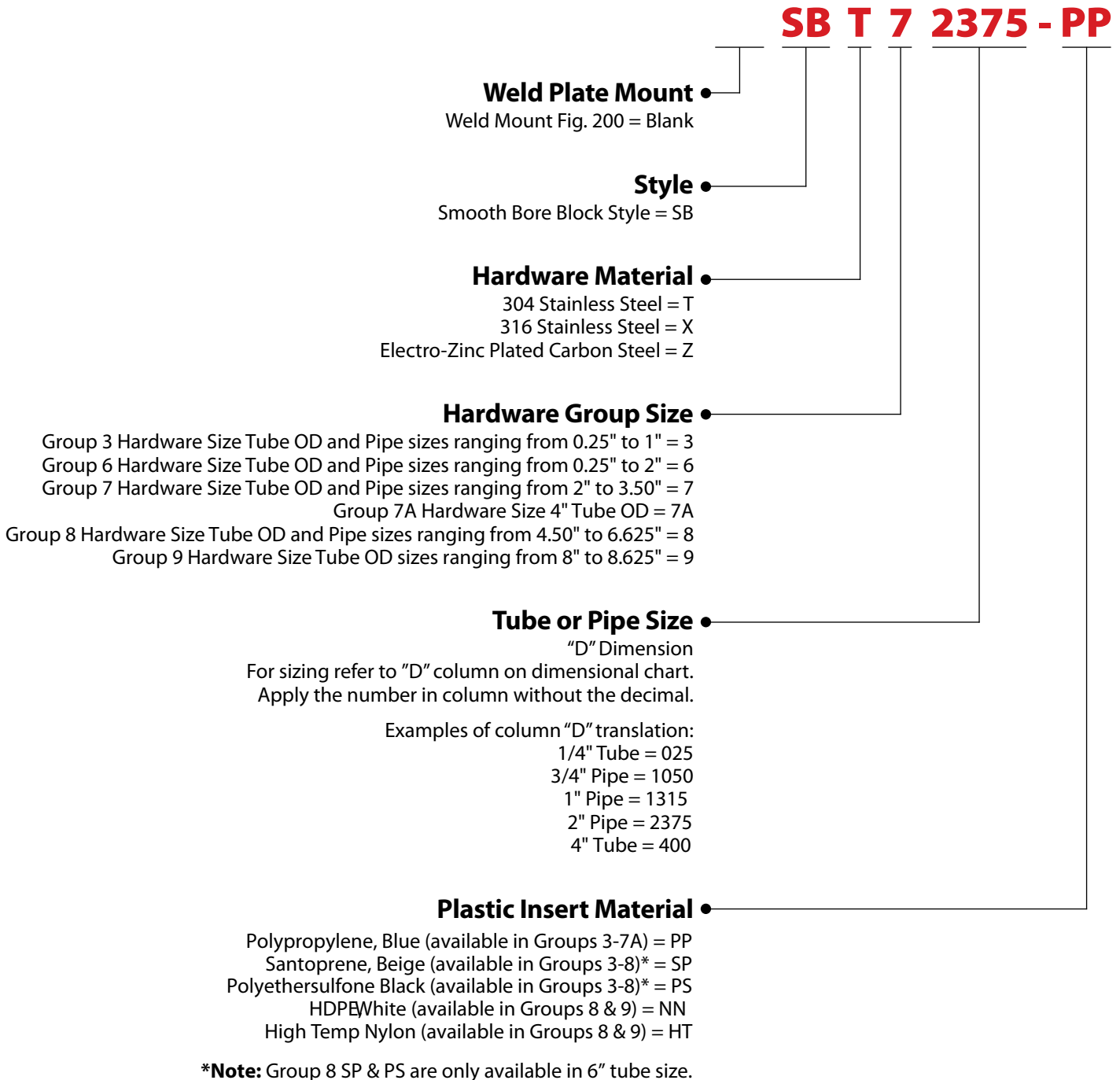

FIG. 200

SMOOTH BORE WELD PLATE MOUNT

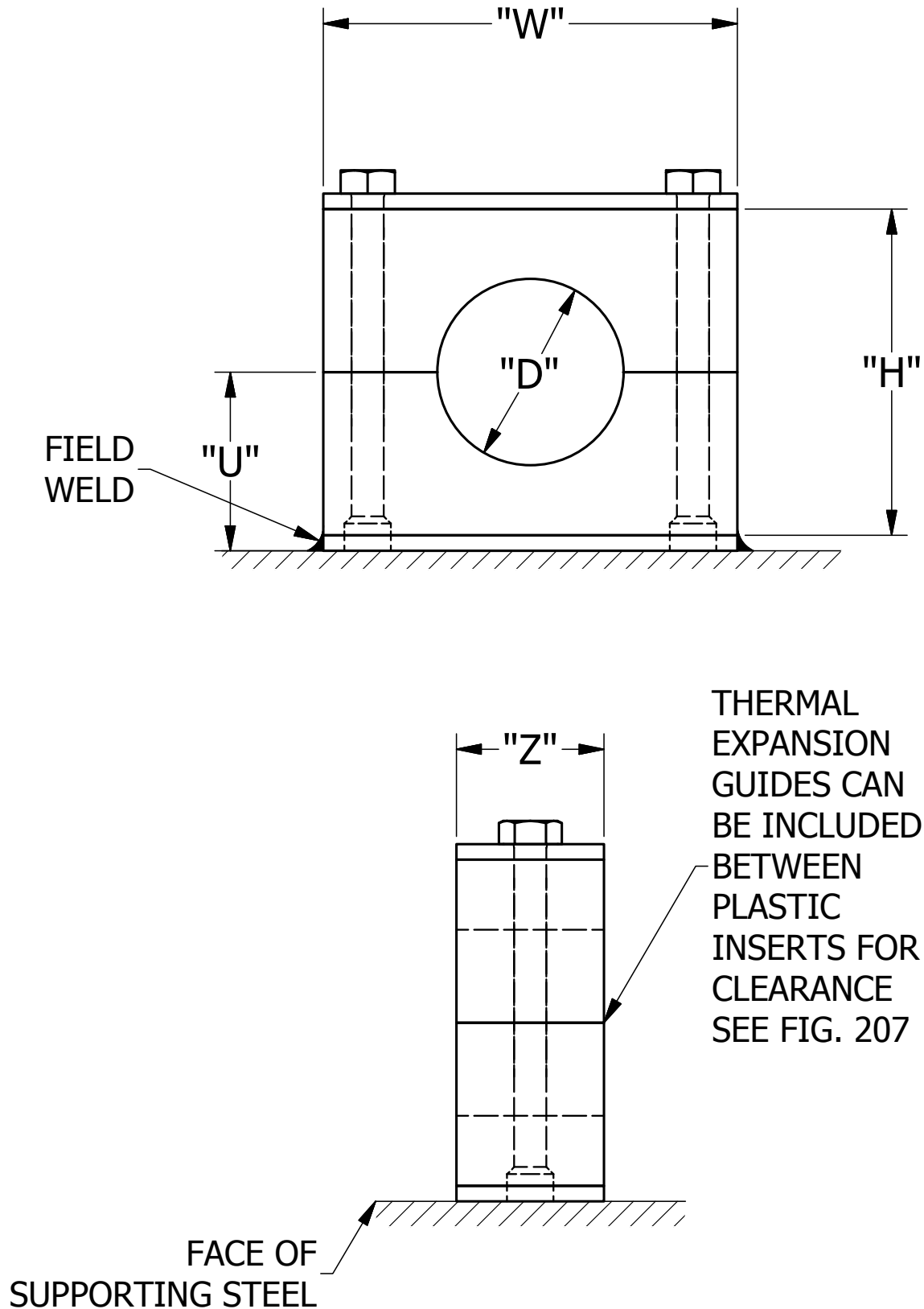

FIG. 200

SMOOTH BORE WELD PLATE MOUNT

GRP NO.	TUBE OR PIPE SIZE	"D" INCHES	W	H	Z	U	BOLT SIZE	LBS.
3	1/4 T	0.250	1.88" (48 mm)	1.38" (35 mm)	1.22" (31 mm)	0.81" (20 mm)	1/4-20	0.4 (0.18 kg)
	3/8 T	0.375						
	1/2 T	0.500						
	3/4 T	0.750						
	1/2 P	0.840						
	1 T	1.000						
6	1/4 T	0.250	3.34" (85 mm)	2.63" (67 mm)	1.22" (31 mm)	1.44" (37 mm)	1/4-20	0.6 (0.27 kg)
	3/8 T	0.375						
	1/2 T	0.500						
	5/8 T	0.625						
	3/4 T	0.750						
	1/2 P	0.840						
	7/8 T	0.875						
	1 T	1.000						
	3/4 P	1.050						
	1-1/4 T	1.250						
	1 P	1.315						
	1-1/2 T	1.500						
	1-1/4 P	1.660						
	1-1/2 P	1.900						
2 T	2.000							
7	2 T	2.000	5.02" (128 mm)	4.38" (111 mm)	1.22" (31 mm)	2.31" (59 mm)	1/4-20	1.1 (0.50 kg)
	2 P	2.375						
	2-1/2 T	2.500						
	2-1/2 P	2.875						
	3 T	3.000						
	3-1/2 T -3 P	3.500						
7A	4 T	4.000	5.77" (147 mm)	4.80" (122 mm)	1.22" (31 mm)	2.54" (65 mm)	1/4-20	1.5 (0.68 kg)
8	6 T	6.000	8.88" (226 mm)	7.65" (194 mm)	1.50" (38 mm)	4.01" (102 mm)	3/8 - 16	4.4 (1.99 kg)
	6P	6.625						
9	8T	8.000	12.50" (318 mm)	10.00" (254 mm)	1.75" (44 mm)	5.38" (137 mm)	5/8 - 11	12.5 (5.70 kg)
	8P	8.625						

FIG. 200

SMOOTH BORE WELD PLATE MOUNT



**Figure 200
Weld Plate Mount**

HEX

COP

CLH (pair)

STW



Smooth Bore Hang Plate Mount

Size Range: 1/4" outside diameter through 6.625" outside diameter

Hardware: 304 Stainless Steel, 316 Stainless Steel, or Electro-Zinc Plated Carbon Steel

Plastic Inserts: Polypropylene (blue)
Santoprene (beige)
Polyethersulfone (black)
HDPE (white)
High Temp Nylon (black)
*See page 85 for temperature ratings

Installations: Hang from threaded rod to desired elevation.

Thermal Expansion Guide: (Optional) Provides for axial expansion of the tube or pipe due to thermal expansion. One set of two per clamp (See Fig. 207 in accessories).

Thermal Expansion Guide Material: Santoprene, 1/16" insert, Black for service identification.

201 Smooth Bore Hang Plate Mount - Part Number Configurator

Part Number Example:

H SB T 6 2375 - PP

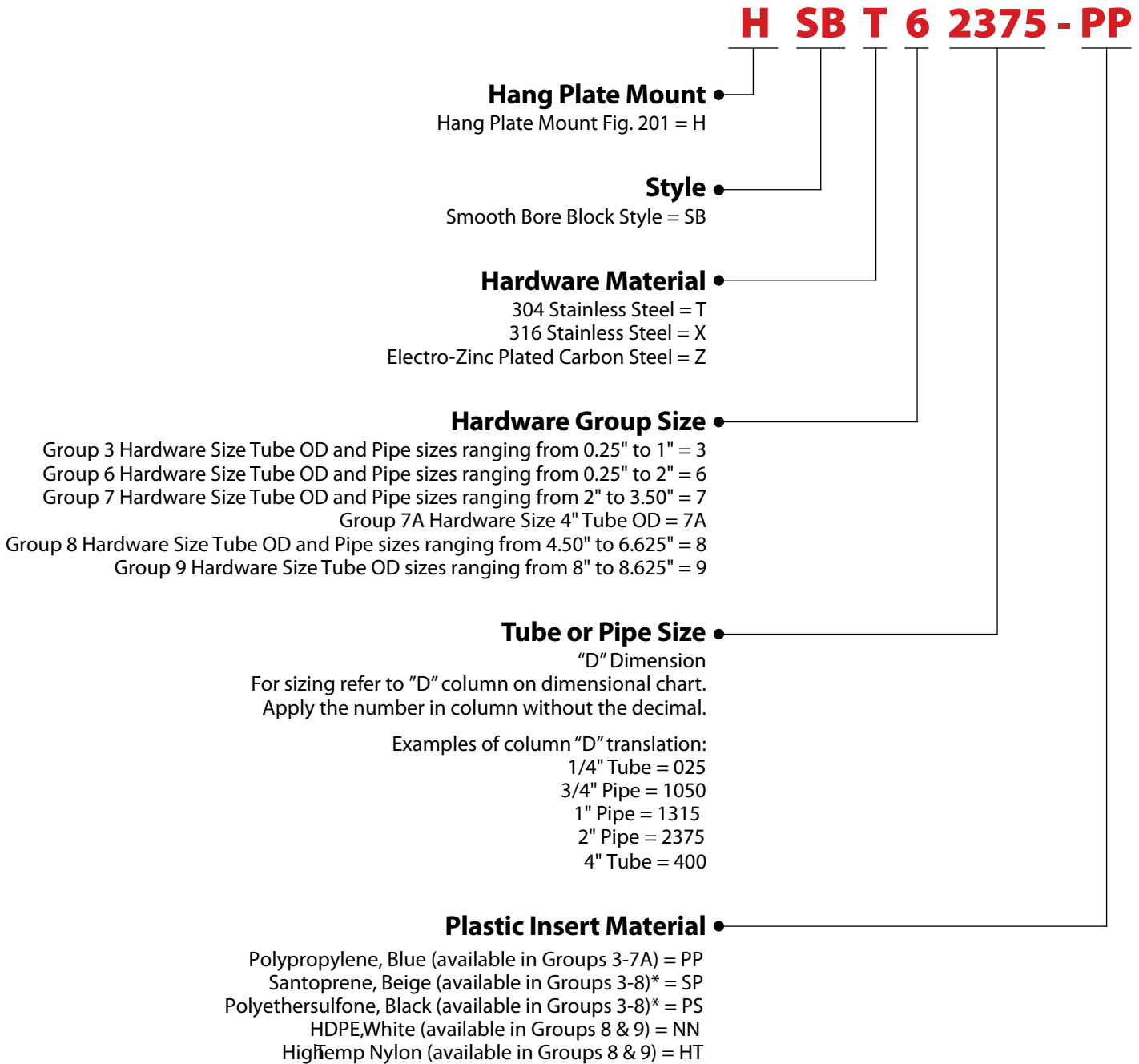

***Note:** Group 8 SP & PS are only available in 6" tube size.

FIG. 201

SMOOTH BORE HANG PLATE MOUNT

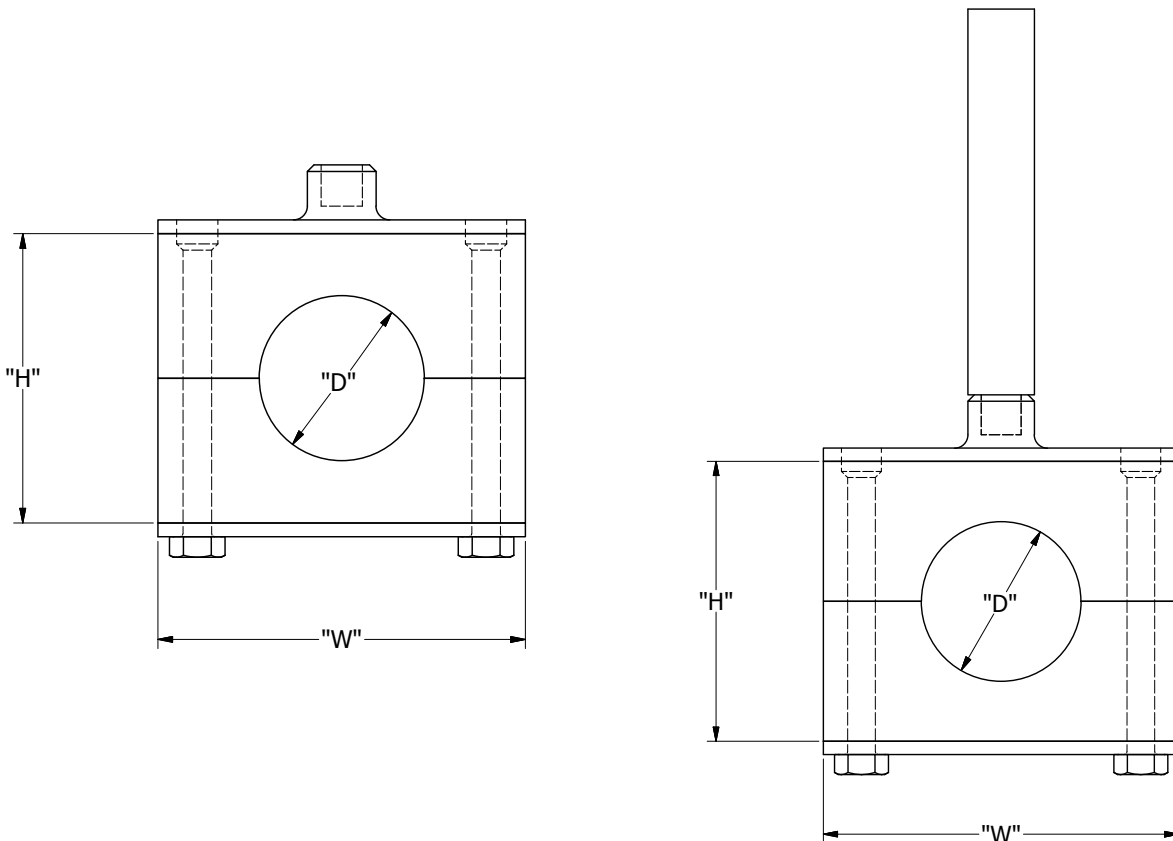
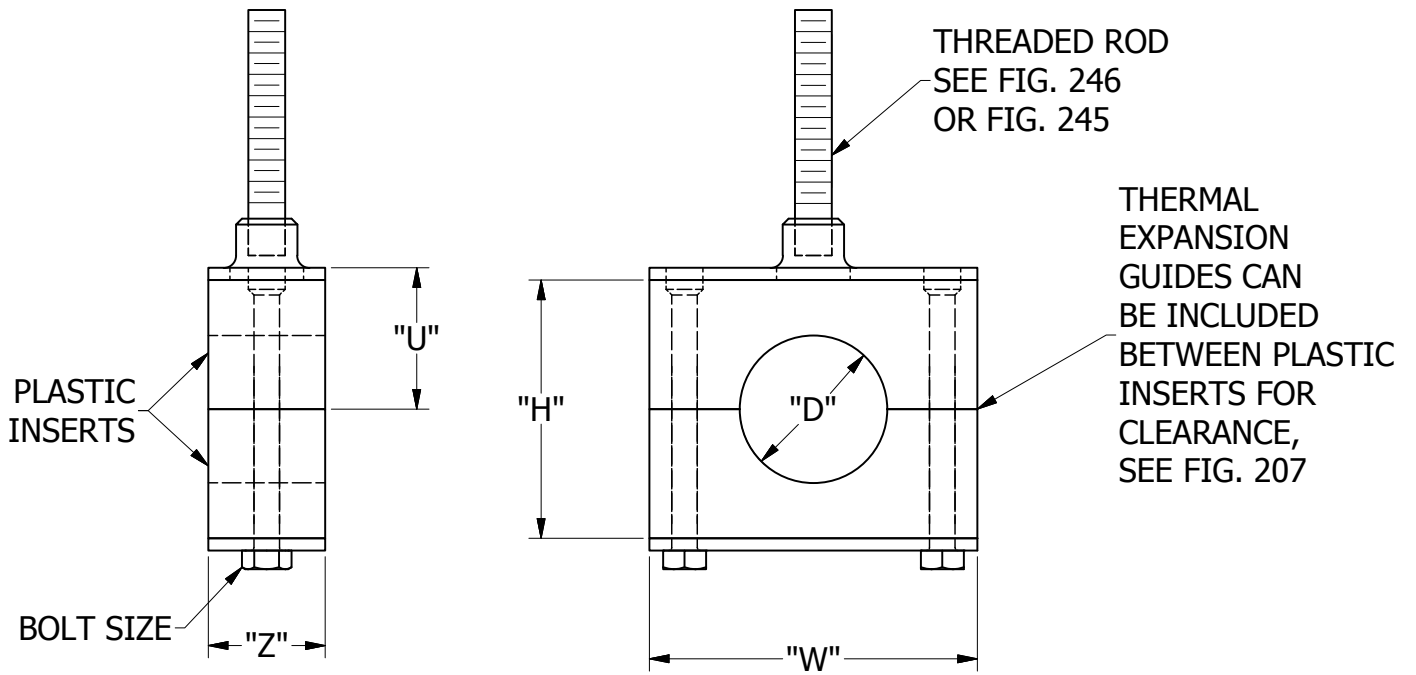

FIG. 201

SMOOTH BORE HANG PLATE MOUNT

GRP NO.	TUBE OR PIPE SIZE	"D" INCHES	W	H	Z	U	BOLT SIZE	HANG NUT	LBS.
3	1/4 T	0.250	1.88" (48 mm)	1.38" (35 mm)	1.22" (31 mm)	0.81" (20 mm)	1/4-20	3/8-16	0.3 (0.14 kg)
	3/8 T	0.375							
	1/2 T	0.500							
	3/4 T	0.750							
	1/2 P	0.840							
	1 T	1.000							
6	1/4 T	0.250	3.34" (85 mm)	2.63" (67 mm)	1.22" (31 mm)	1.44" (37 mm)	1/4-20	3/8-16	0.5 (0.23 kg)
	3/8 T	0.375							
	1/2 T	0.500							
	5/8 T	0.625							
	3/4 T	0.750							
	1/2 P	0.840							
	7/8 T	0.875							
	1 T	1.000							
	3/4 P	1.050							
	1-1/4 T	1.250							
	1 P	1.315							
	1-1/2 T	1.500							
	1-1/4 P	1.660							
	1-1/2 P	1.900							
2 T	2.000								
7	2 T	2.000	5.02" (128 mm)	4.38" (111 mm)	1.22" (31 mm)	2.31" (59 mm)	1/4-20	3/8-16	1.0 (0.45 kg)
	2 P	2.375							
	2-1/2 T	2.500							
	2-1/2 P	2.875							
	3 T	3.000							
	3-1/2 T -3 P	3.500							
7A	4 T	4.000	5.77" (147 mm)	4.80" (122 mm)	1.22" (31 mm)	2.54" (65 mm)	1/4-20	3/8-16*	1.3 (0.59 kg)
8	6 T	6.000	8.88" (226 mm)	7.65" (194 mm)	1.50" (38 mm)	4.01" (102 mm)	3/8 - 16	5/8-11	4.4 (1.99 kg)
	6P	6.625							

* Also available with a 1/2-13 thread

FIG. 201

SMOOTH BORE HANG PLATE MOUNT



Figure 201
Hang Plate Mount

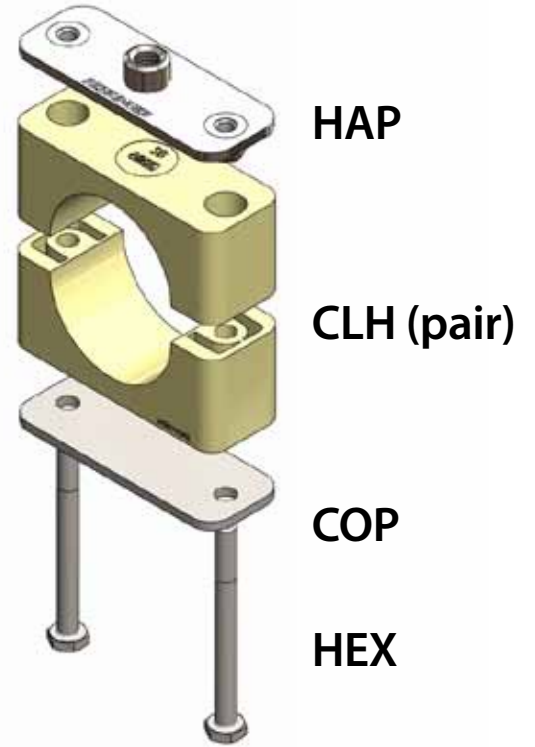



Smooth Bore Base Plate Mount

Size Range: 1/4" outside diameter through 6.625" outside diameter

Hardware: 304 Stainless Steel, 316 Stainless Steel, or Electro-Zinc Plated Carbon Steel

Plastic Inserts: Polypropylene (blue)
Santoprene (beige)
Polyethersulfone (black)
HDPE (white)
High Temp Nylon (black)
*See page 85 for temperature ratings

Installations: Locate bolt holes in mounting structure and either tap into structure or use 1/4-20 bolt and nut to secure

Thermal Expansion Guide: (Optional) Provides for axial expansion of the tube or pipe due to thermal expansion. One set of two per clamp (See Fig. 207 in accessories).

Thermal Expansion Guide Material: Santoprene, 1/16" insert, Black for service identification.

202 Smooth Bore Base Plate Mount - Part Number Configurator

Part Number Example:

B SB X 3 100 - SP

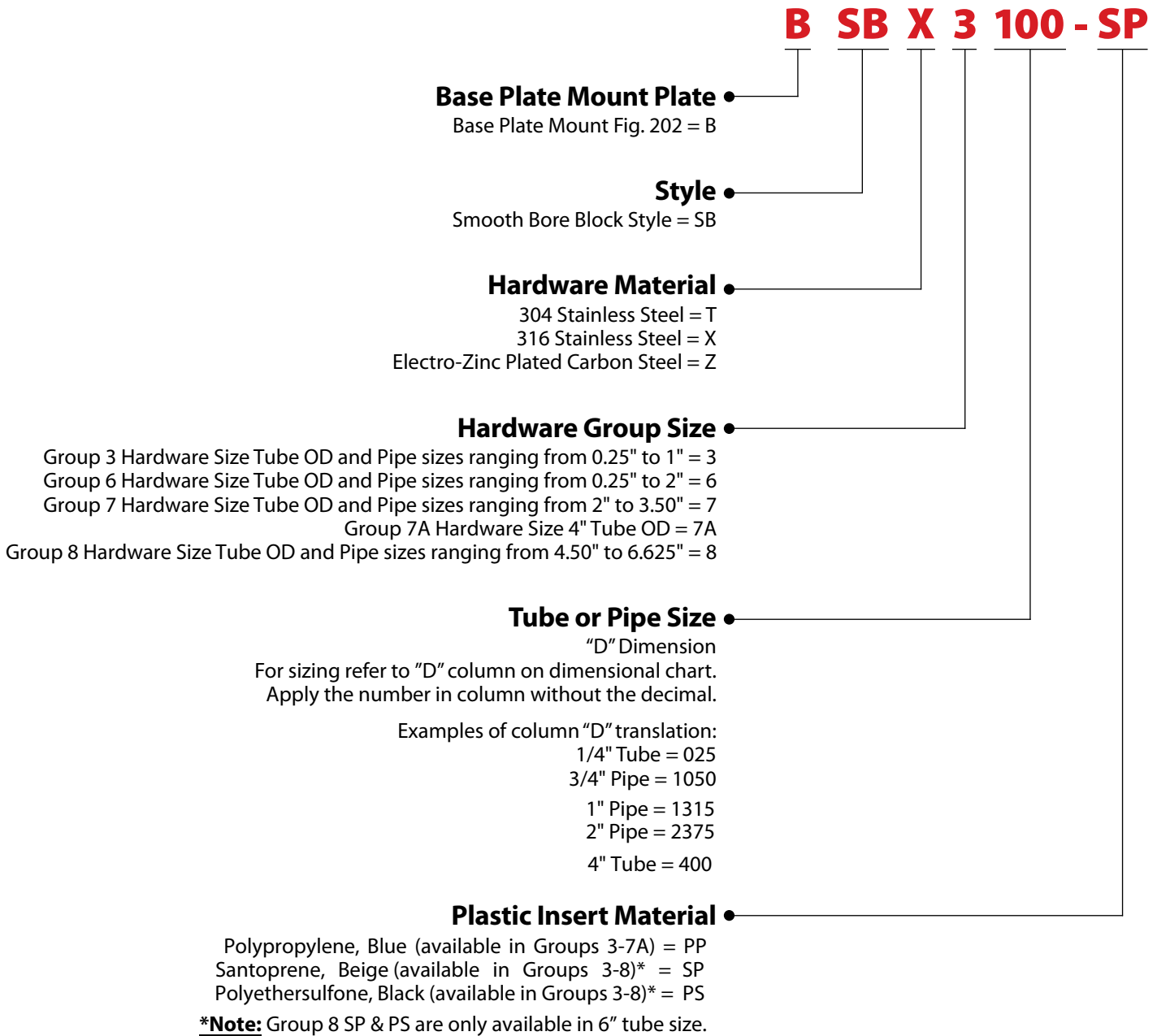

FIG. 202

SMOOTH BORE BASE PLATE MOUNT

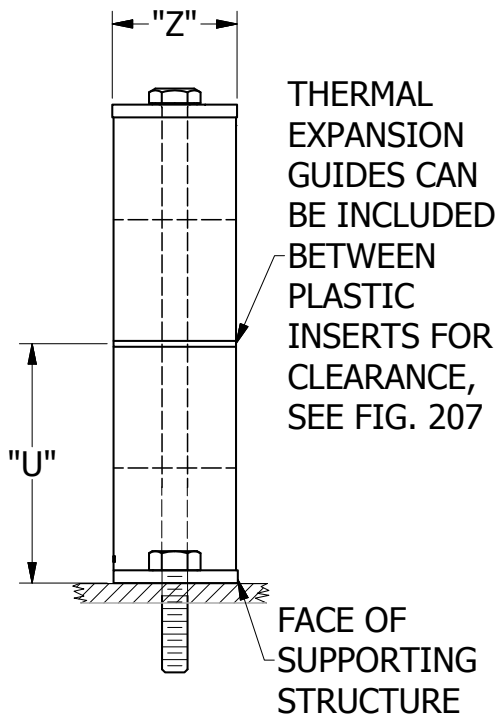
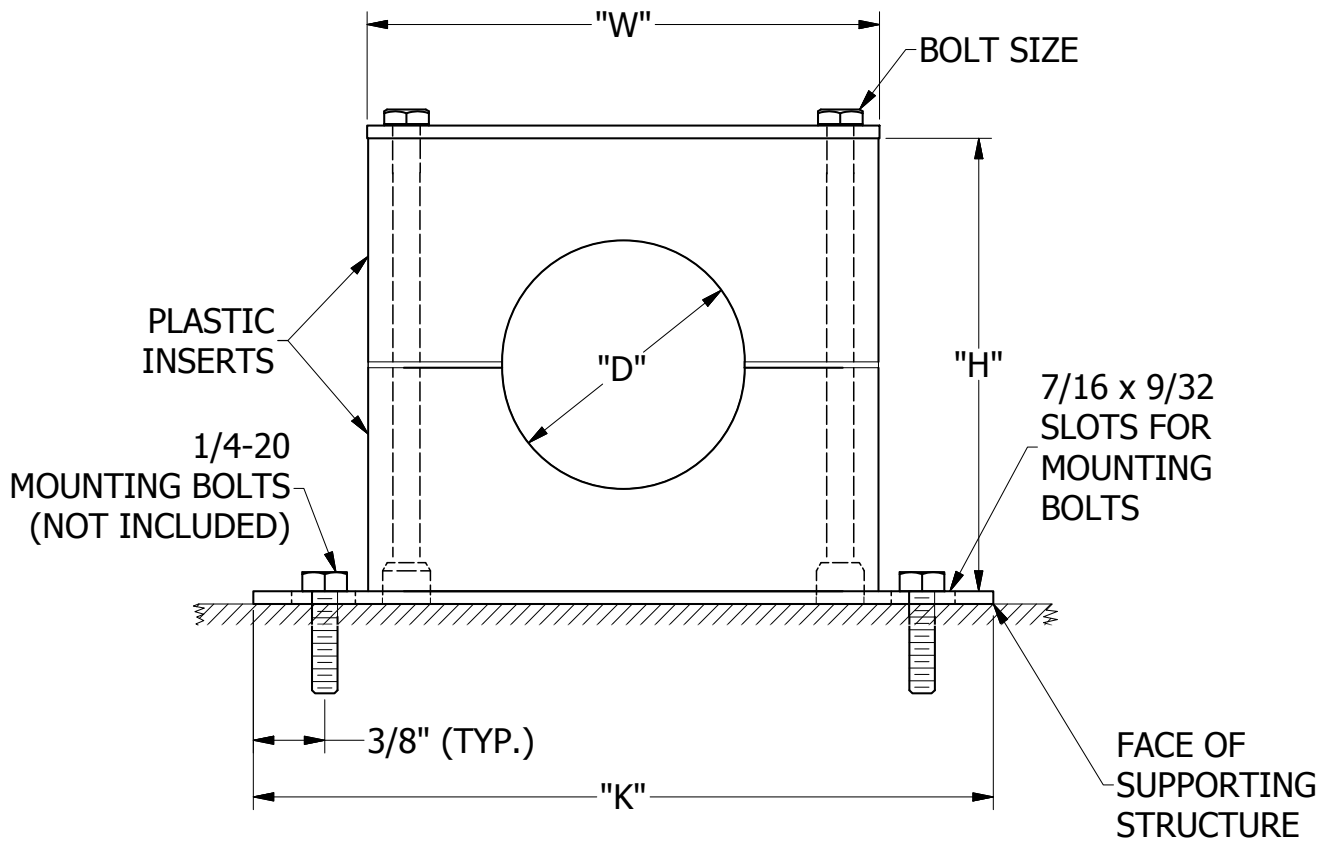

FIG. 202

SMOOTH BORE BASE PLATE MOUNT

GRP NO.	TUBE OR PIPE SIZE	"D" INCHES	W	H	Z	U	K	BOLT SIZE	LBS.
3	1/4 T	0.250	1.88" (48 mm)	1.38" (35 mm)	1.22" (31 mm)	0.81" (20 mm)	3.50" (89 mm)	1/4-20	0.4 (0.18 kg)
	3/8 T	0.375							
	1/2 T	0.500							
	3/4 T	0.750							
	1/2 P	0.840							
	1 T	1.000							
6	1/4 T	0.250	3.34" (85 mm)	2.63" (67 mm)	1.22" (31 mm)	1.44" (37 mm)	4.88" (124 mm)	1/4-20	0.6 (0.27 kg)
	3/8 T	0.375							
	1/2 T	0.500							
	5/8 T	0.625							
	3/4 T	0.750							
	1/2 P	0.840							
	7/8 T	0.875							
	1 T	1.000							
	3/4 P	1.050							
	1-1/4 T	1.250							
	1 P	1.315							
	1-1/2 T	1.500							
	1-1/4 P	1.660							
	1-1/2 P	1.900							
2 T	2.000								
7	2 T	2.000	5.02" (128 mm)	4.38" (111 mm)	1.22" (31 mm)	2.31" (59 mm)	6.50" (165 mm)	1/4-20	1.1 (0.50 kg)
	2 P	2.375							
	2-1/2 T	2.500							
	2-1/2 P	2.875							
	3 T	3.000							
	3-1/2 T -3 P	3.500							
7A	4 T	4.000	5.77" (147 mm)	4.8" (122 mm)	1.22" (31 mm)	2.54" (65 mm)	7.19" (183 mm)	1/4-20	1.5 (0.68 kg)
8	6 T	6.000	8.88" (226 mm)	7.65" (194 mm)	1.50" (38 mm)	4.01" (102 mm)	11.25" (286 mm)	3/8 - 16	4.4 (1.99 kg)
	6P	6.625							

FIG. 202

SMOOTH BORE BASE PLATE MOUNT

Figure 202 Base Plate Mount

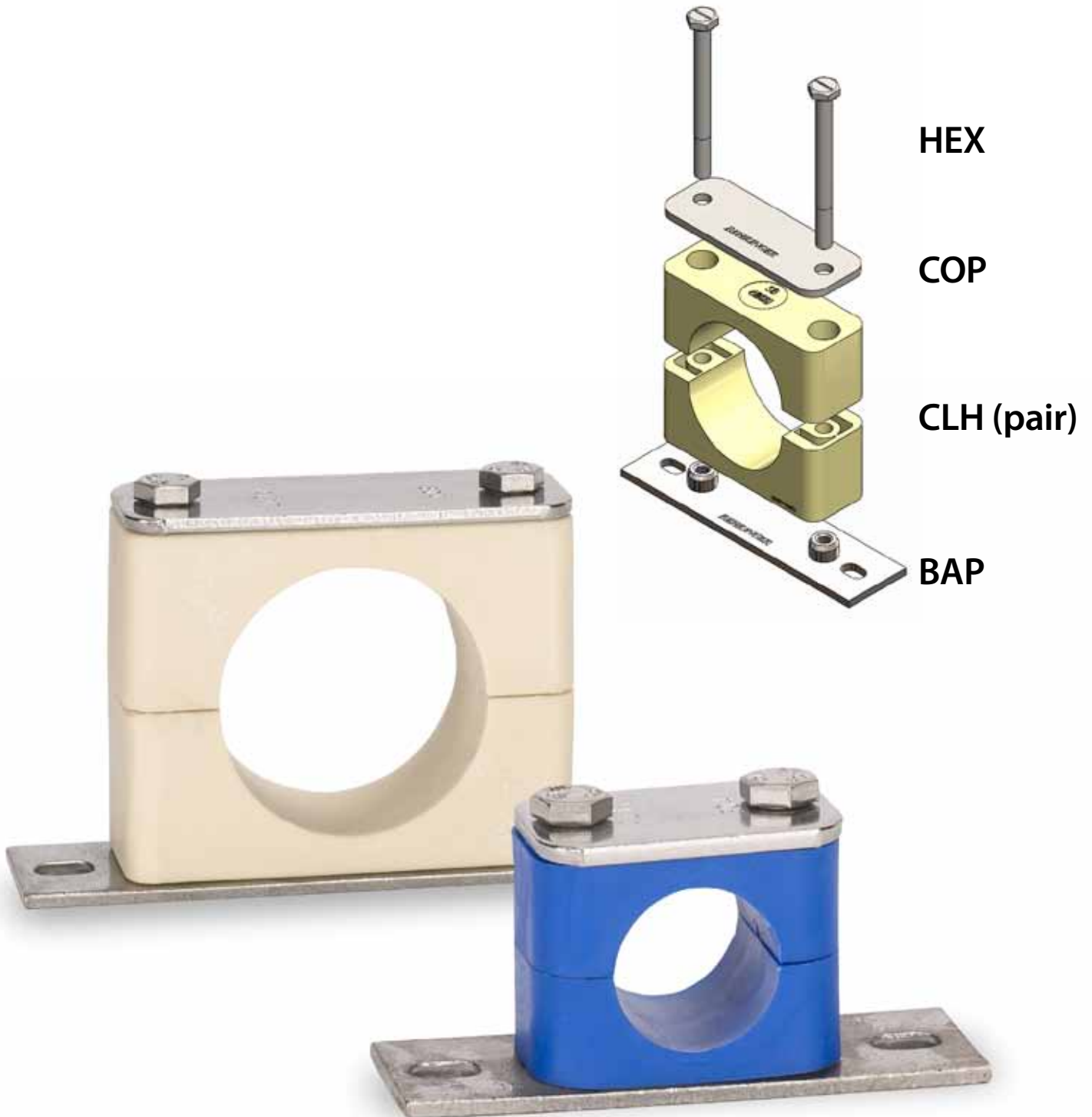

Rail Mount

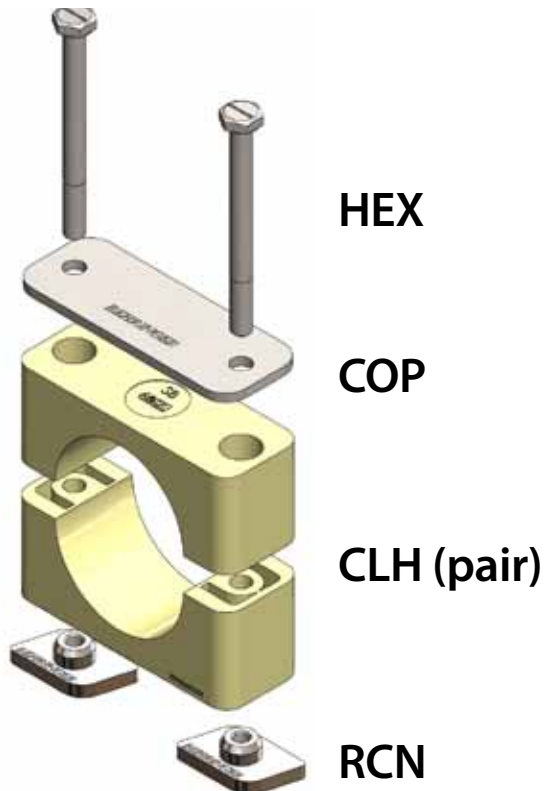

RAL-1 Rail Mounting

Size Range: Rail Accommodates Clamps from 1/4" through 4" tube

Hardware: 304 Stainless Steel, 316 Stainless Steel, or Electro-Zinc Plated Carbon Steel

Installations: Weld Rail (RAL-1) to structure or supporting member. Slide clamp weld plate into rail, locate proper position and assemble clamp. Tightening hex bolts of clamp will lock clamp into position.

Alternate Mounting Option: RCN-1 Rail Nut (RCN-1) may also be used when mounting to Behringer's proprietary mounting rail (RAL-1).

203 Rail Mounting (RAL-1) - Part Number Configurator

Part Number Example:

ST - RA1 - 99 - T - 6FT

ST - RA1 - 99 - T - 6FT

- **Standard Rail 1**
ST
- **Rail Size**
Rail-1
- **Universal Group Size**
99
- **Hardware Material**
 - 304 Stainless Steel = T
 - 316 Stainless Steel = X
 - Electro-Zinc Plated Carbon Steel = Z
 - Carbon Steel = C

- **Rail Length**
(Standard Length) 72" = 6FT
48" = 4FT
24" = 2FT
16" = 16"

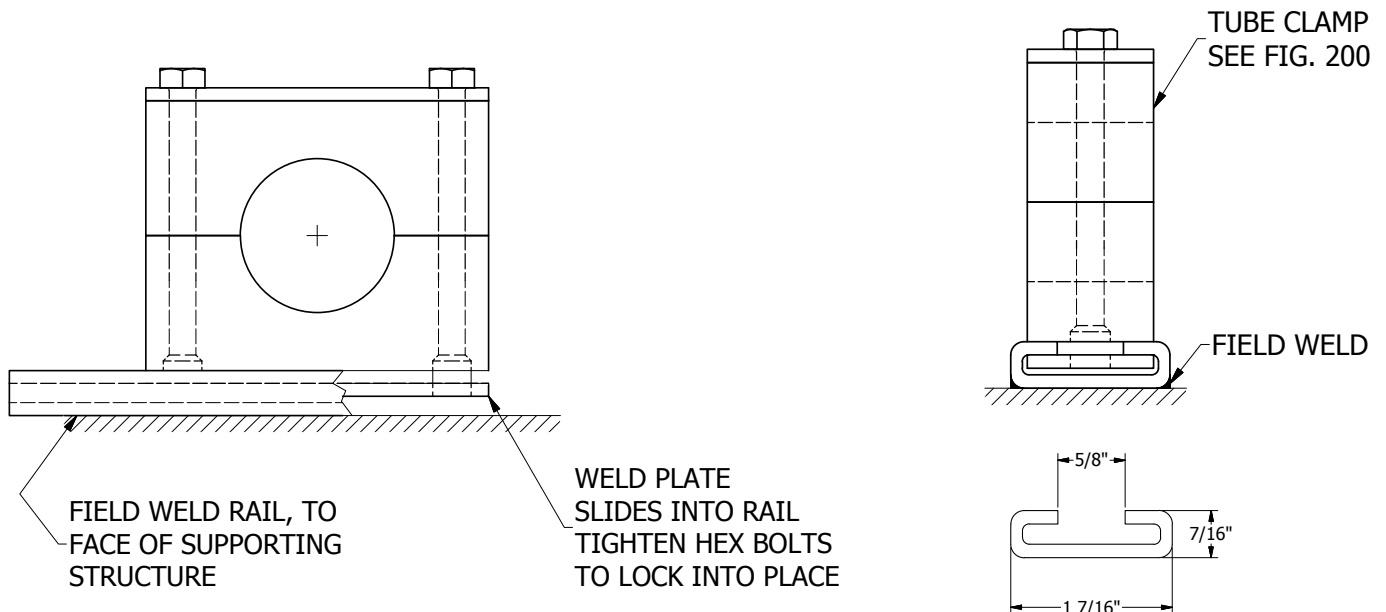



Stacking Kit

Size Range: Any double combination of sizes 1/4" outside diameter through 3.5" outside diameter (Group 7 housing)

Hardware: 304 Stainless Steel, 316 Stainless Steel, or Electro-Zinc Plated Carbon Steel

Plastic Inserts: Polypropylene (blue)
Santoprene (beige)
Polyethersulfone (black)
*See page 85 for temperature ratings

Thermal Expansion Guide: (Optional) Provides for axial expansion of the tube or pipe due to thermal expansion. One set of two per clamp (See Fig. 207 in accessories).

Thermal Expansion Guide Material: Santoprene, 1/16" insert, Black for service identification

NOTE: This is sold as a modular component ONLY. Must order Fig. 200, 201 or 202 as a bottom assembly in addition to each stacking kit.

204 Stacking Kit - Part Number Configurator

Part Number Example:

SK SB Z 3 75 - PP

SK SB Z 3 75 - PP

Stacking Kit ●

Stacking Kit Fig. 204 = SK

Style ●

Smooth Bore Block Style = SB

Hardware Material ●

304 Stainless Steel = T
316 Stainless Steel = X
Electro-Zinc Plated Carbon Steel = Z

Hardware Group Size ●

Group 3 Hardware Size Tube OD and Pipe sizes ranging from 0.25" to 1" = 3
Group 6 Hardware Size Tube OD and Pipe sizes ranging from 0.25" to 2" = 6
Group 7 Hardware Size Tube OD and Pipe sizes ranging from 2" to 3.50" = 7

Tube or Pipe Size ●

"D" Dimension
For sizing refer to "D" column on dimensional chart.
Apply the number in column without the decimal.

Examples of column "D" translation:
1/4" Tube = 025
3/4" Pipe = 1050
1" Pipe = 1315
2" Pipe = 2375

Plastic Insert Material ●

Polypropylene, Blue (available in Groups 3-7) = PP
Santoprene, Beige (available in Groups 3-8)* = SP
Polyethersulfone Black (available in Groups 3-8)* = PS

***Note:** Group 8 SP & PS are only available in 6" tube size.

FIG. 204

STACKING KIT

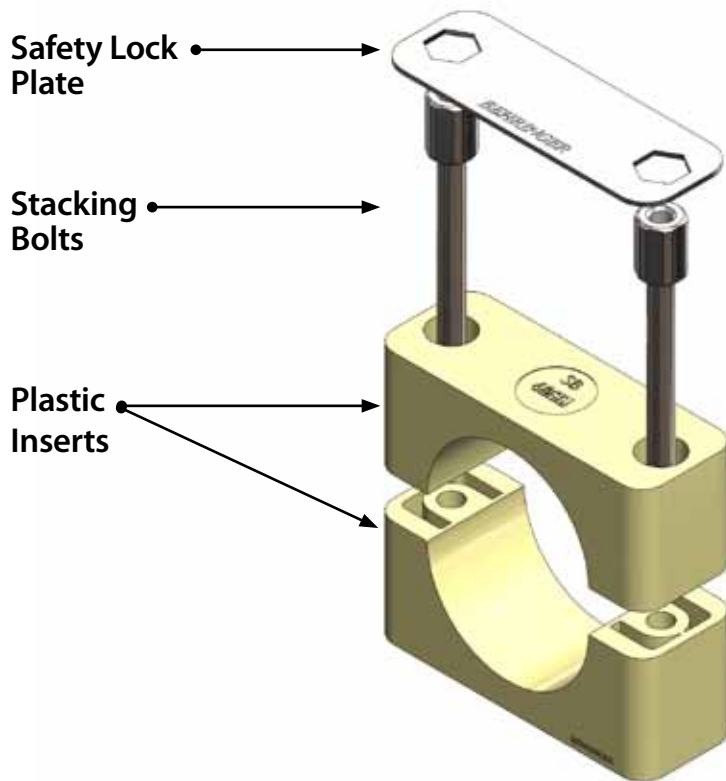
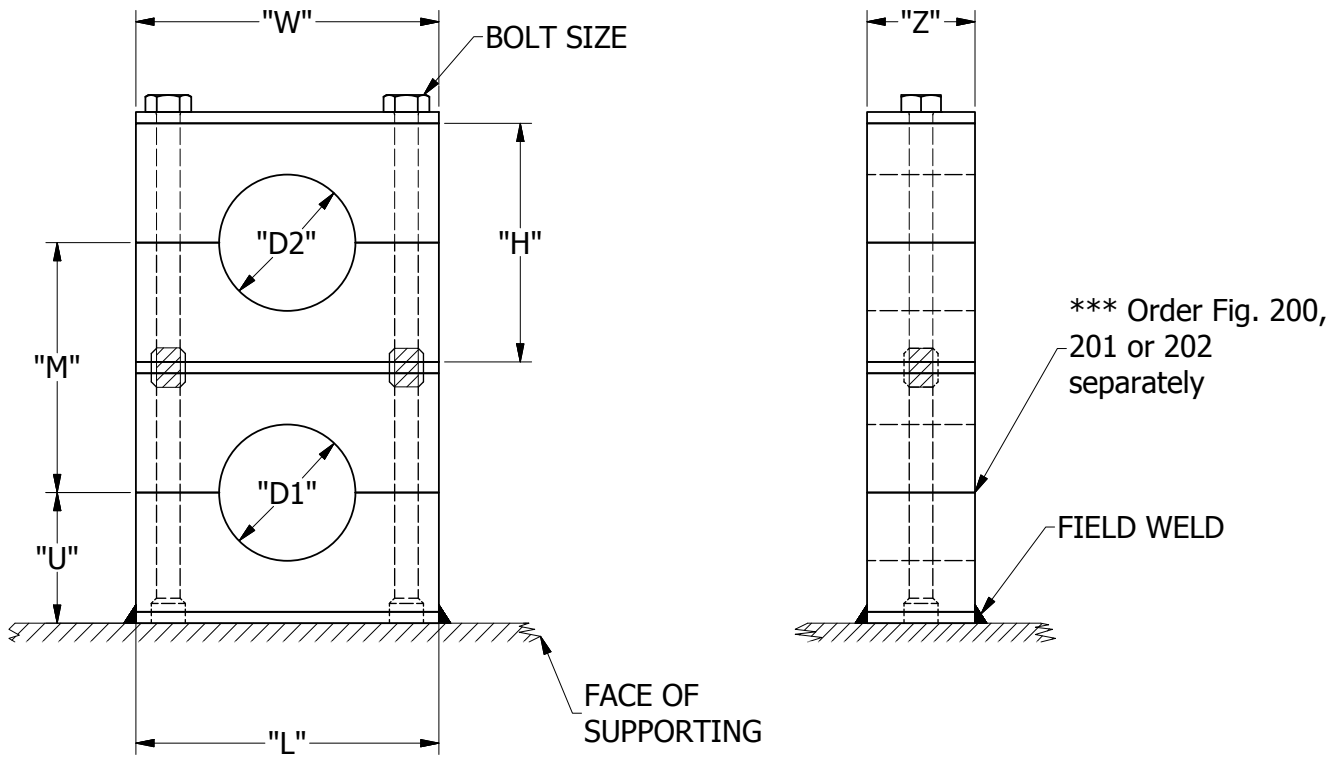

FIG. 204

STACKING KIT

GRP NO.	TUBE OR PIPE SIZE	"D" INCHES	W	H	Z	U	L	M	BOLT SIZE
3	1/4 T	0.250	1.88" (48 mm)	1.38" (35 mm)	1.22" (31 mm)	0.81" (20 mm)	2.02" (51 mm)	1.44" (37 mm)	1/4-20
	3/8 T	0.375							
	1/2 T	0.500							
	3/4 T	0.750							
	1/2 P	0.840							
	1 T	1.000							
6	1/4 T	0.250	3.34" (85 mm)	2.63" (67 mm)	1.22" (31 mm)	1.44" (37 mm)	3.46" (88 mm)	2.69" (68 mm)	1/4-20
	3/8 T	0.375							
	1/2 T	0.500							
	5/8 T	0.625							
	3/4 T	0.750							
	1/2 P	0.840							
	7/8 T	0.875							
	1 T	1.000							
	3/4 P	1.050							
	1-1/4 T	1.250							
	1 P	1.315							
	1-1/2 T	1.500							
	1-1/4 P	1.660							
	1-1/2 P	1.900							
7	2 T	2.000	5.02" (128 mm)	4.38" (111 mm)	1.22" (31 mm)	2.31" (59 mm)	5.02" (128 mm)	4.44" (113 mm)	1/4-20
	2 P	2.375							
	2-1/2 T	2.500							
	2-1/2 P	2.875							
	3 T	3.000							
	3-1/2 T -3 P	3.500							

FIG. 204

STACKING KIT



Figure 204
Stacking Kit

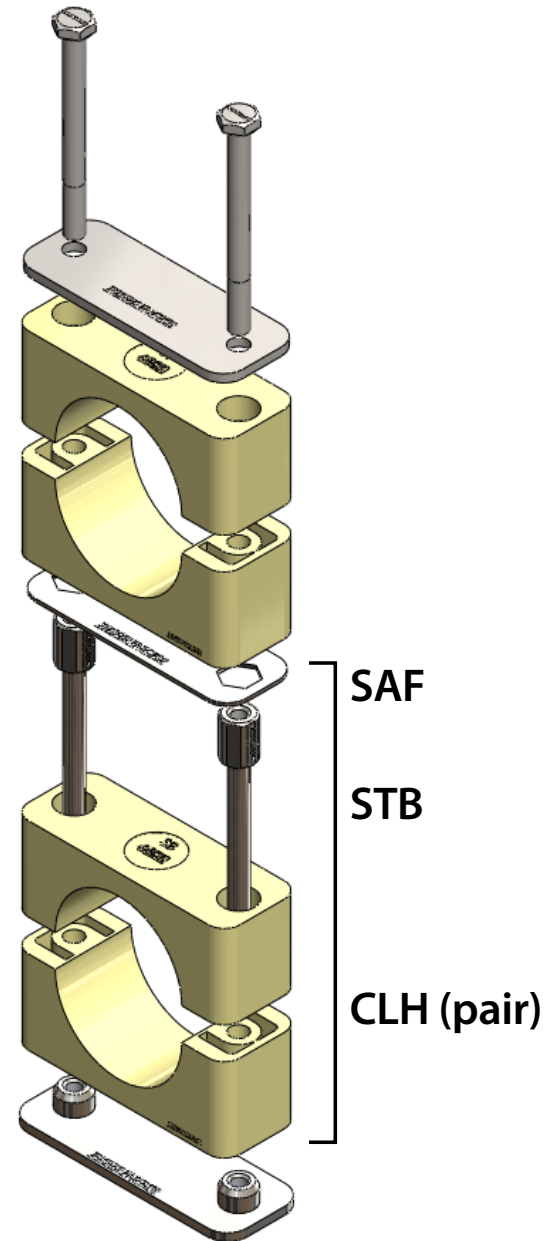



UniStrut Mount

Size Range: 1/4" outside diameter through 4" outside diameter (Group 7A housing).

Hardware: 304 Stainless Steel, 316 Stainless Steel, or Electro-Zinc Plated Carbon Steel

Plastic Inserts: Polypropylene (blue)
Santoprene (beige)
Polyethersulfone (black)
*See page 85 for temperature ratings

Installation: After unistrut rail position has been established, position 2 unistrut rail nuts in channel where desired to accept plastic inserts. Place pipe or tube in clamp perpendicular to unistrut channel. Torque down on clamp bolts to lock assembly in place.

Thermal Expansion Guide: (Optional) Provides for axial expansion of the tube or pipe due to thermal expansion. One set of two per clamp (See Fig. 207 in accessories).

Thermal Expansion Guide Material: Santoprene, 1/16" insert, Black for service identification

211 Smooth Bore UniStrut Mount - Part Number Configurator

Part Number Example:

U SB T 6 200 - SP

U SB T 6 200 - SP

Unistrut Mount ●

Unistrut Mount Fig. 211 = U

Style ●

Smooth Bore Block Style = SB

Hardware Material ●

304 Stainless Steel = T

316 Stainless Steel = X

Electro-Zinc Plated Carbon Steel = Z

Hardware Group Size ●

Group 3 Hardware Size Tube OD and Pipe sizes ranging from 0.25" to 1" = 3

Group 6 Hardware Size Tube OD and Pipe sizes ranging from 0.25" to 2" = 6

Group 7 Hardware Size Tube OD and Pipe sizes ranging from 2" to 3.50" = 7

Group 7A Hardware Size 4" Tube OD = 7A

Tube or Pipe Size ●

"D" Dimension

For sizing refer to "D" column on dimensional chart.

Apply the number in column without the decimal.

Examples of column "D" translation:

1/4" Tube = 025

3/4" Pipe = 1050

1" Pipe = 1315

2" Pipe = 2375

4" Tube = 400

Plastic Insert Material ●

Polypropylene, Blue (available in Groups 3-7A) = PP

Santoprene, Beige (available in Groups 3-8)* = SP

Polyethersulfone, Black (available in Groups 3-8)* = PS

***Note:** Group 8 SP & PS are only available in 6" tube size.

FIG. 211

SMOOTH BORE UNISTRUT MOUNT

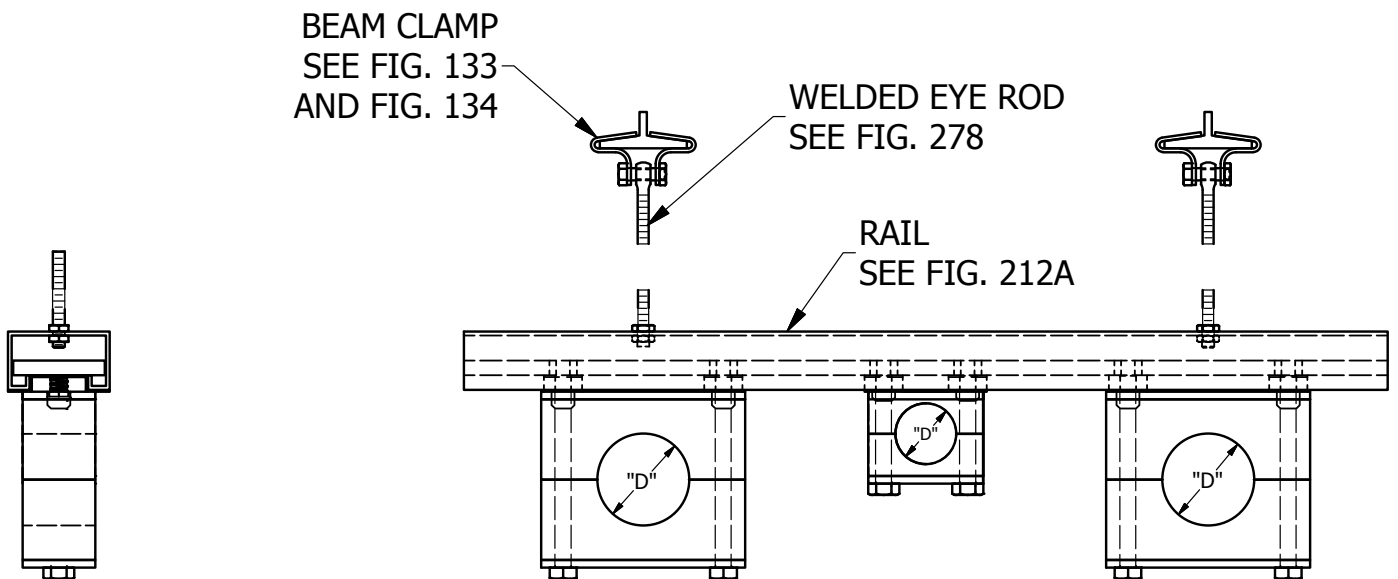
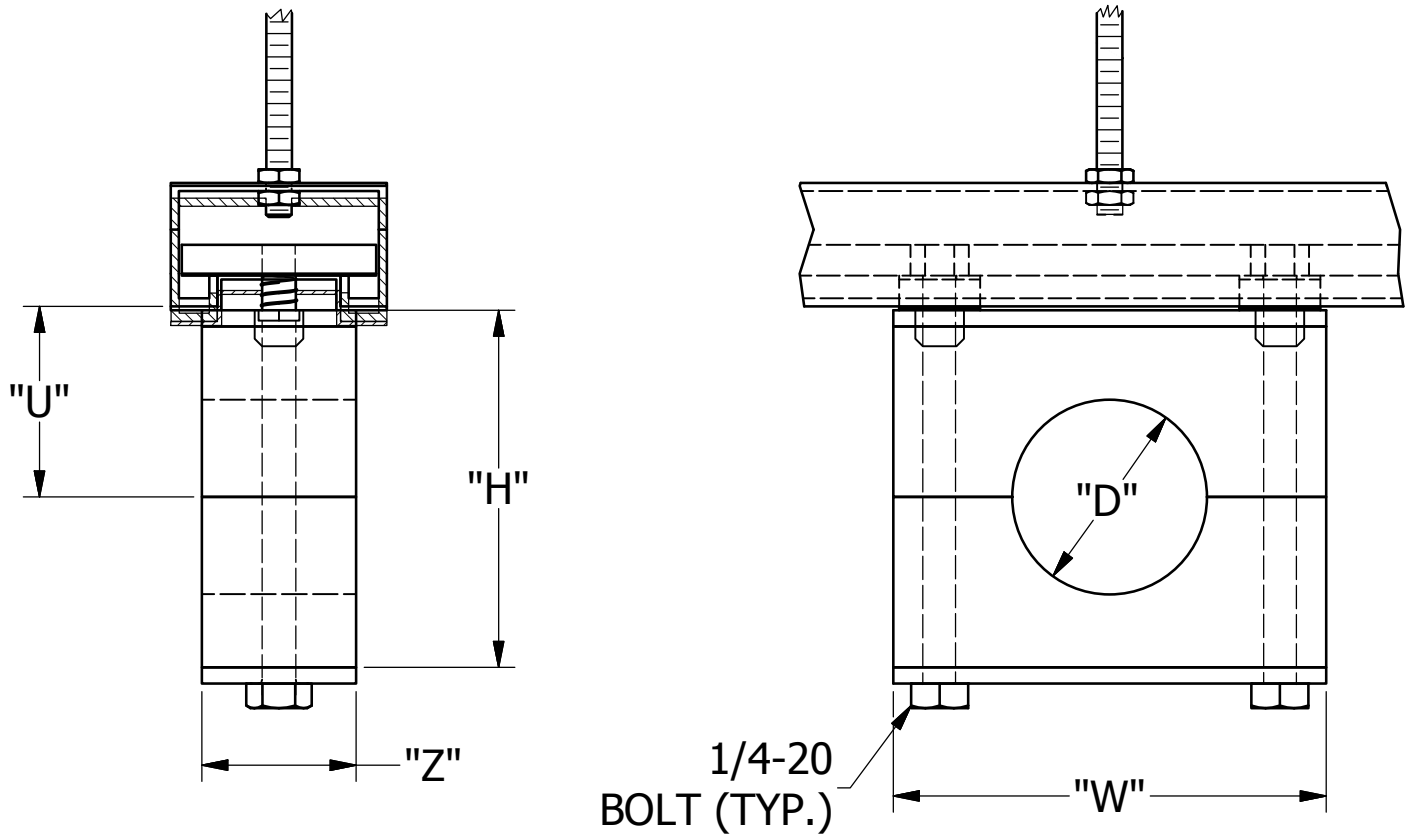
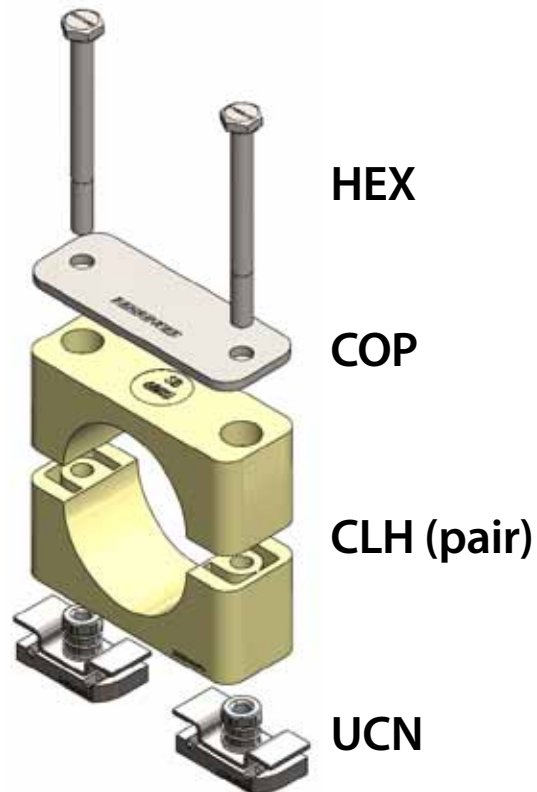

FIG. 211

SMOOTH BORE UNISTRUT MOUNT

GRP NO.	TUBE OR PIPE SIZE	"D" INCHES	INCHES				LBS.
			W	H	Z	U	
3	1/4 T	0.250	1.88" (48 mm)	1.38" (35 mm)	1.22" (31 mm)	0.75" (19 mm)	0.4 (0.18 kg)
	3/8 T	0.375					
	1/2 T	0.500					
	3/4 T	0.750					
	1/2 P	0.840					
	1 T	1.000					
6	1/4 T	0.250	3.34" (85 mm)	2.63" (67 mm)	1.22" (31 mm)	1.38" (35 mm)	0.6 (0.27 kg)
	3/8 T	0.375					
	1/2 T	0.500					
	5/8 T	0.625					
	3/4 T	0.750					
	1/2 P	0.840					
	7/8 T	0.875					
	1 T	1.000					
	3/4 P	1.050					
	1-1/4 T	1.250					
	1 P	1.315					
	1-1/2 T	1.500					
	1-1/4 P	1.660					
	1-1/2 P	1.900					
2 T	2.000						
7	2 T	2.000	5.00" (127 mm)	4.38" (111 mm)	1.22" (31 mm)	2.25" (57 mm)	1.1 (0.50 kg)
	2 P	2.375					
	2-1/2 T	2.500					
	2-1/2 P	2.875					
	3 T	3.000					
	3-1/2 T -3 P	3.500					
7A	4 T	4.000	5.77" (147 mm)	4.8" (122 mm)	1.22" (31 mm)	2.48" (62 mm)	1.5 (0.68 kg)

Figure 211 Unistrut Mount



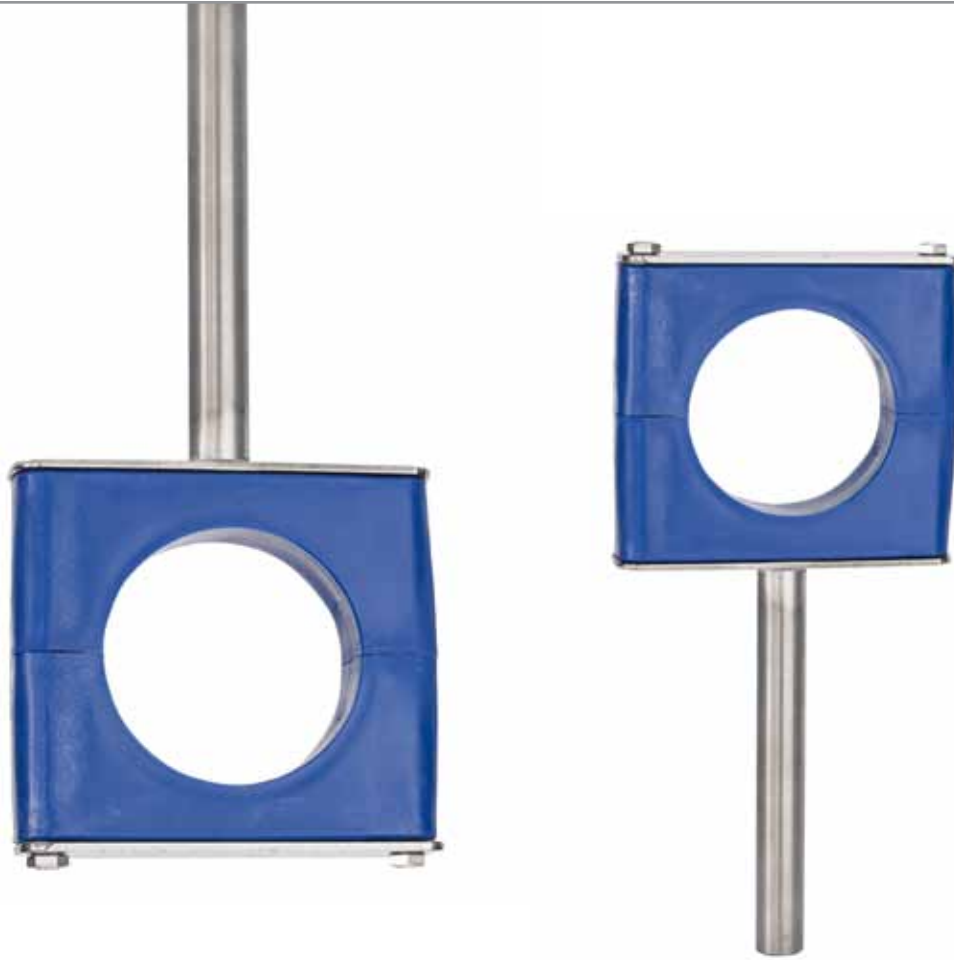

Smooth Bore Rod Mount

Size Range: 1/4" outside diameter through 6.625" outside diameter.

Hardware: 304 Stainless Steel, 316 Stainless Steel, or Electro-Zinc Plated Carbon Steel.

Plastic Inserts: Polypropylene (blue)
Santoprene (beige)
Polyethersulfone (black)
HDPE (white)
High Temp Nylon (black)
*See page 85 for temperature ratings

Installation: Cut bar in field to proper length. Field weld hang or floor mount bar to support structure. Fig 221 can also be used in combination with the figure 225 or 226 stanchions. This combination will allow the support to be adjusted telescopically to the tube or pipe elevation. Call customer service for the price and availability of special rod lengths.

Thermal Expansion Guide: (Optional) Provides for axial expansion of the tube or pipe due to thermal expansion. One set of two per clamp (See Fig. 207 in accessories).

Thermal Expansion Guide Material: Santoprene, 1/16" insert, Black for service identification.

221 Smooth Bore Rod Mount - Part Number Configurator

Part Number Example:

R SB Z 6 1050 - SP - 06

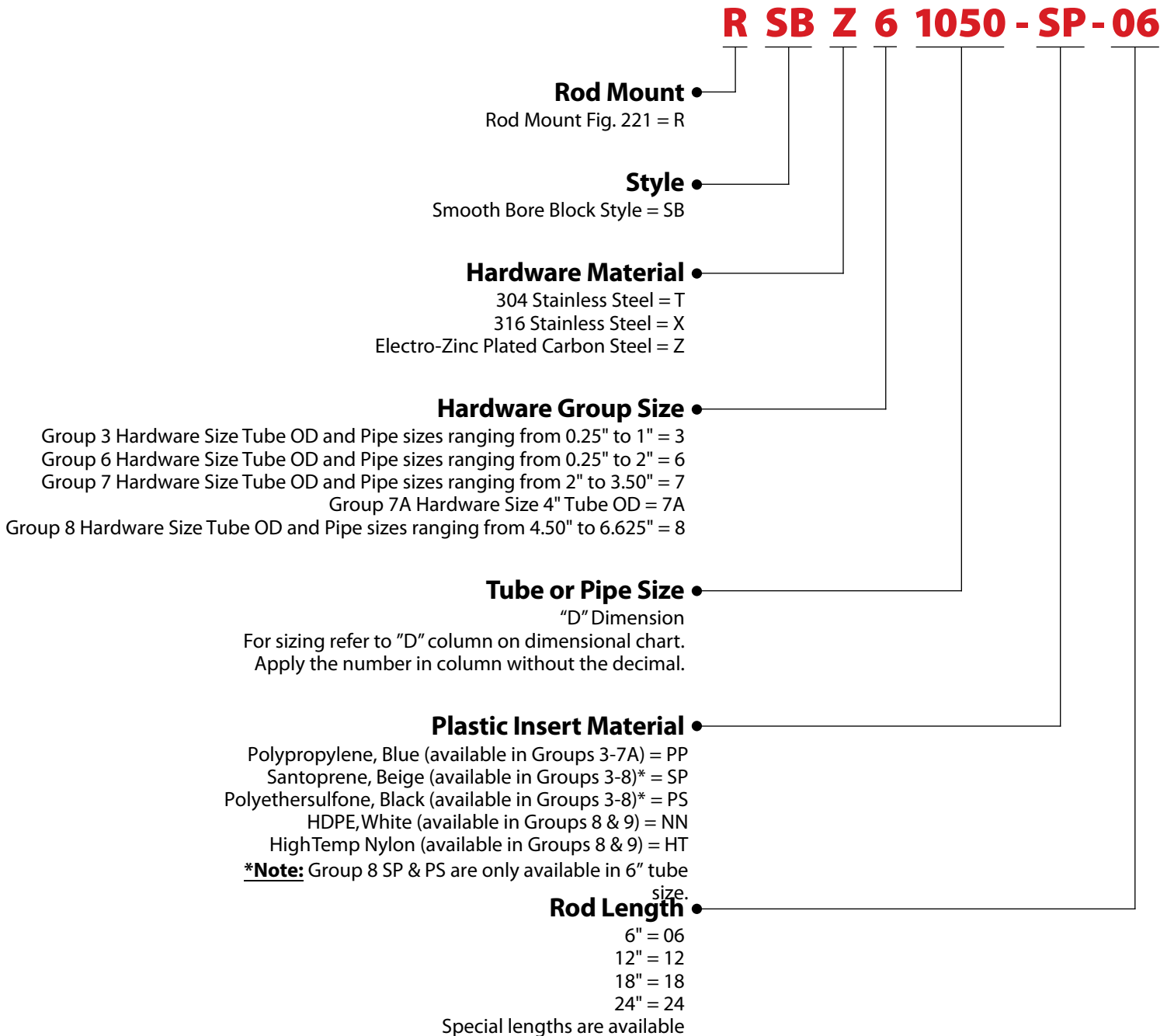

FIG. 221

SMOOTH BORE ROD MOUNT

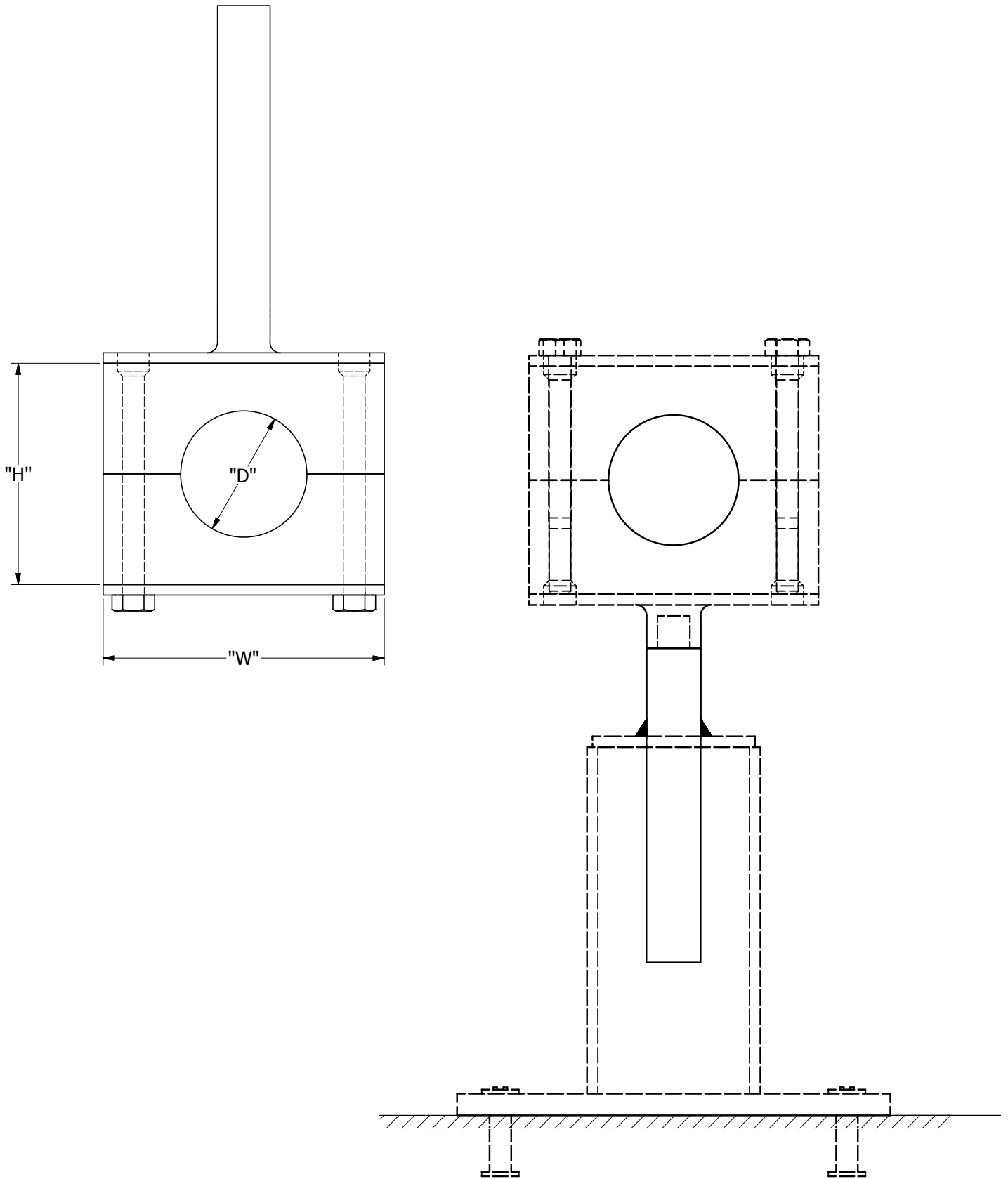

FIG. 221

SMOOTH BORE ROD MOUNT

GRP NO.	TUBE OR PIPE SIZE	"D" INCHES	W	Z	U	BOLT SIZE	"A" ROD DIA.
3	1/4 T	0.250	1.88" (48 mm)	1.22" (31 mm)	0.81" (20 mm)	1/4-20	0.5" (12.7 mm)
	3/8 T	0.375					
	1/2 T	0.500					
	3/4 T	0.750					
	1/2 P	0.840					
	1 T	1.000					
6	1/4 T	0.250	3.34" (85 mm)	1.22" (31 mm)	1.44" (37 mm)	1/4-20	0.5" (12.7 mm)
	3/8 T	0.375					
	1/2 T	0.500					
	5/8 T	0.625					
	3/4 T	0.750					
	1/2 P	0.840					
	7/8 T	0.875					
	1 T	1.000					
	3/4 P	1.050					
	1-1/4 T	1.250					
	1 P	1.315					
	1-1/2 T	1.500					
	1-1/4 P	1.660					
	1-1/2 P	1.900					
2 T	2.000						
7	2 T	2.000	5.00" (127 mm)	1.22" (31 mm)	2.31" (59 mm)	1/4-20	0.75" (19 mm)
	2 P	2.375					
	2-1/2 T	2.500					
	2-1/2 P	2.875					
	3 T	3.000					
	3-1/2 T -3 P	3.500					
7A	4 T	4.000	5.77" (147 mm)	1.22" (31 mm)	2.54" (65 mm)	1/4-20	0.75" (19 mm)
8	6 T	6.000	8.88" (226 mm)	1.50" (38 mm)	4.01" (102 mm)	3/8 - 16	1.00" (25.4 mm)
	6P	6.625					



Stanchions

Fig. 223 Telescopic Adjusting Round Floor Stand **65-67**
[About](#) | [Part Number Configurator](#) | [Schematic](#)

Fig. 224 CH Series Rod Stand Plate **68-70**
[About](#) | [Part Number Configurator](#) | [Schematic](#)

Fig. 225 Telescopic Adjusting Stanchion - Hang Mount **71-74**
[About](#) | [Part Number Configurator](#) | [Schematic](#) | [Photos](#)

Fig. 226 Telescopic Adjusting Stanchion - Floor Mount **75-77**
[About](#) | [Part Number Configurator](#) | [Schematic](#)



Telescopic Adjusting Round Floor Mount Stand

The Telescopic Adjusting Round Floor Mount Stand allows the housing's rod elevation to be adjusted up to 2" from the base plate's surface. The rod attached to the housing slides inside the base plate's elevation adjustment tube (.560 ID x .750 OD). This fine tune adjustment allows the installer to quickly increase the support's elevation to match the tube's distance from the floor. The base plate can be supplied with or without anchor bolt holes. Clamp and Rod are sold separately. Anchor bolts not supplied by Behringer.

Base Plate Sizing: RSP1 & RSP2 - 0.25" to 2.00" OD tube & pipe size
RSP3 & RSP4 - 2.05" to 4.50" OD tube & pipe sizes
RSP5 & RSP6 - 5.08" to 6.00" OD tube & pipe sizes

Hardware: 304 Stainless Steel, 316 Stainless Steel, Carbon Steel & Electro-Zinc Plated Carbon Steel

Finish: MILL = Fabricated steel and welds are a mill finish
BUFF = Fabricated steel and weld are buffed to remove weld discoloration and splatter
BLND = Fabricated steel is polished and welds are blended

Special finishes and painted stands are available, call Customer Service for price and availability.

Welding Instructions:

Contact Behringer Sales for more information.

223 Telescopic Adjusting Round Floor Mount Stand - Part Number Configurator

Part Number Example:

TBS - X - B - RSP1 - MILL

TBS - X - B - RSP1 - MILL

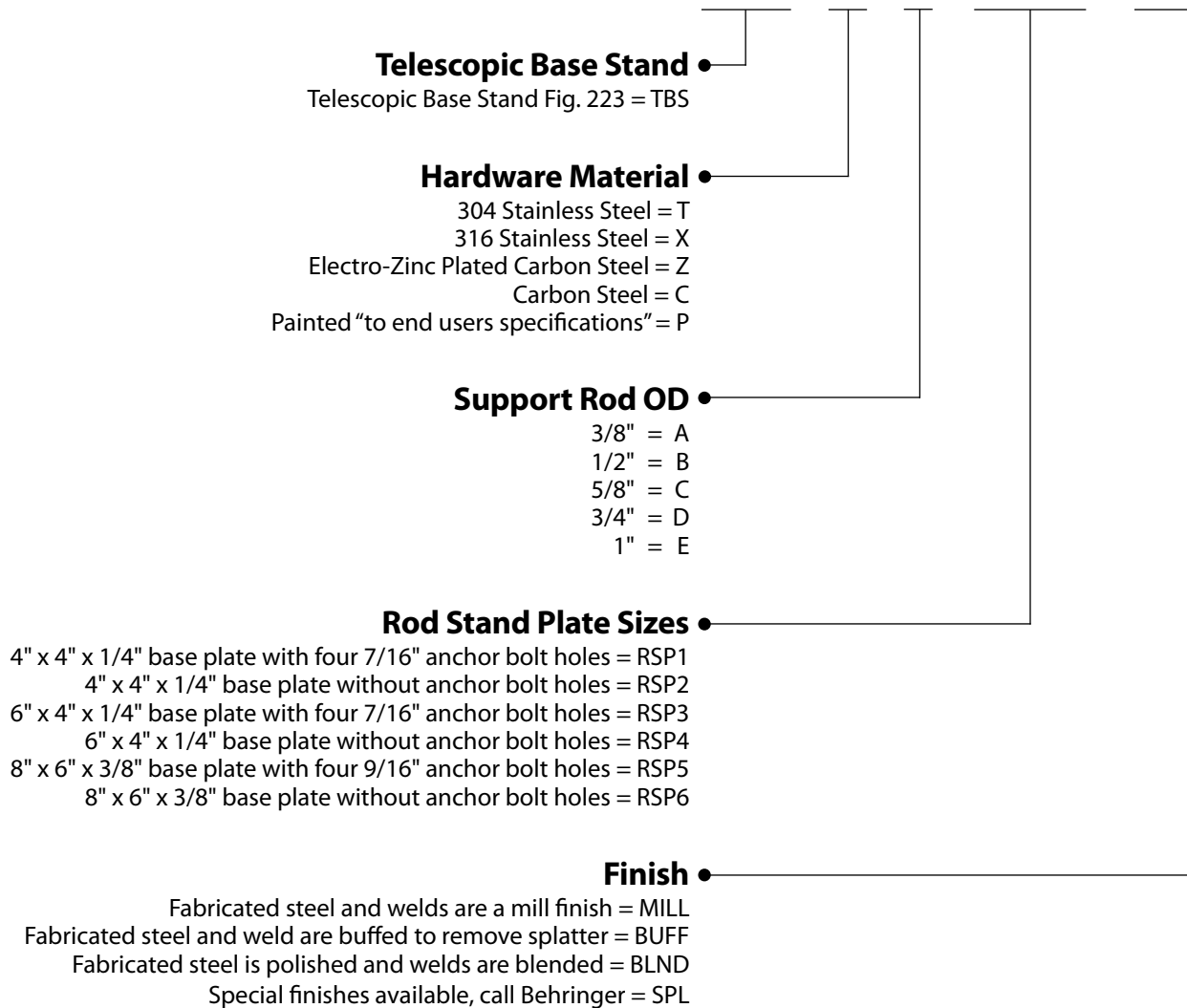

Note: Clamp and Rod sold separately

FIG. 223

TELESCOPIC ADJUSTING ROUND FLOOR MOUNT STAND

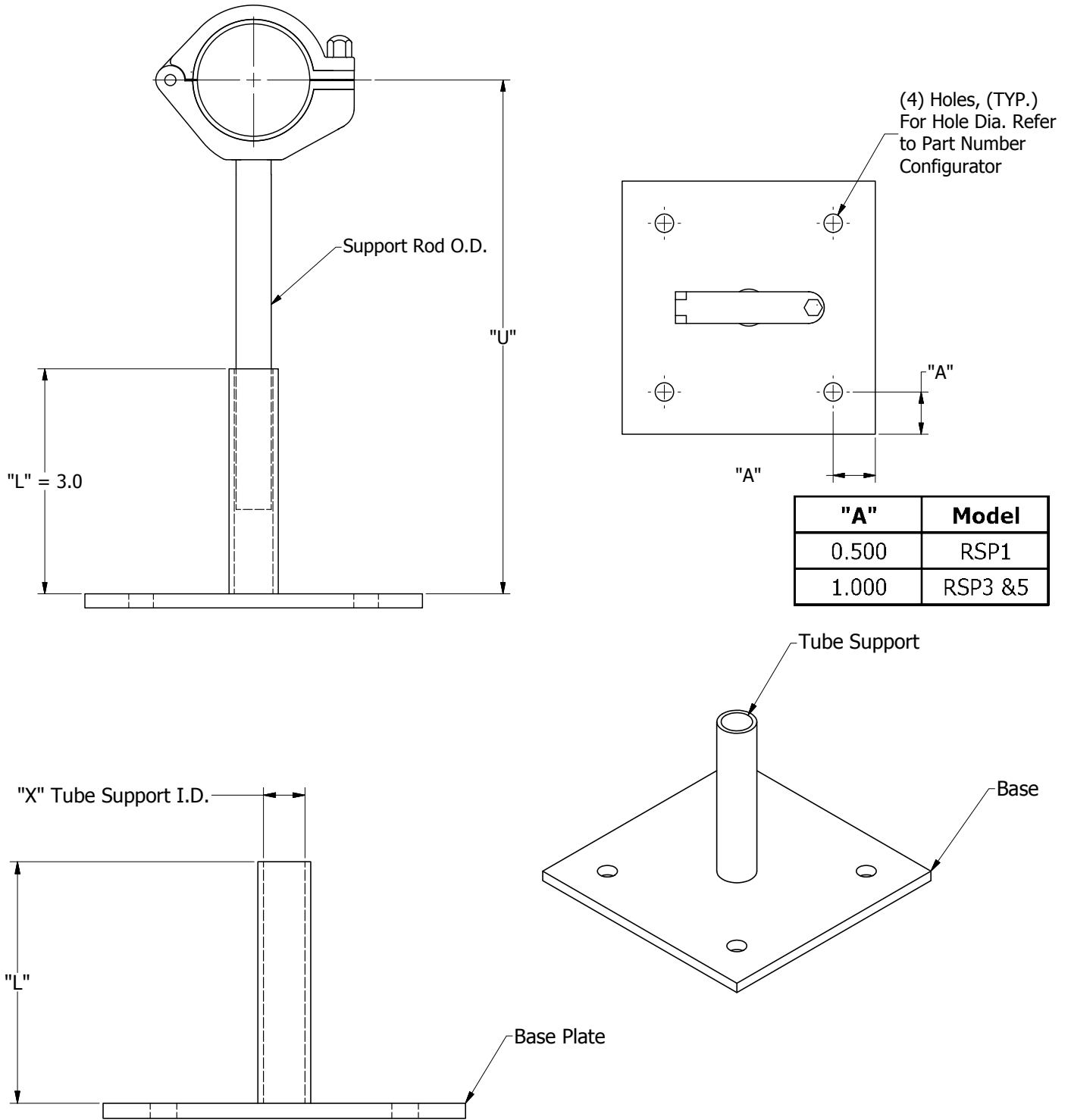



CH Series Rod Stand Plate

One piece CH Series Rod Stand Plate with rod cut to specified length. The rod is welded to the base plate, which can be supplied with or without anchor bolt-holes. Anchor bolts not supplied by Behringer.

The height is calculated from the top of the plate to centerline of tube or pipe. Please refer to "U" min column in catalog for minimum height of the required RH series product.

Base Plate Sizing: RSP1 & RSP2 - 0.25" to 2.00" OD tube & pipe size
RSP3 & RSP4 - 2.05" to 4.50" OD tube & pipe sizes
RSP5 & RSP6 - 5.08" to 6.00" OD tube & pipe sizes

Hardware: 304 Stainless Steel, 316 Stainless Steel

Finish: MILL = Fabricated steel and welds are a mill finish
BUFF = Fabricated steel and weld are buffed to remove splatter
BLND = Fabricated steel is polished and welds are blended

Special finishes and painted stands are available, call Customer Service for price and availability.

Cautionary Note: If using a Dynamic housing as a sliding base support, it is recommended to tack weld the housing once slope has been verified. This will ensure that the base plate remains flat or parallel to the resting surface. This particularly applies to high temperature service lines that will experience thermal cycling.

224 CH Series Rod Stand Plate - Part Number Configurator

Part Number Example:

CHR - PS - 100 - X - 06 - RSP1 - BLND

CHR - PS - 100 - X - 06 - RSP1 - BLND

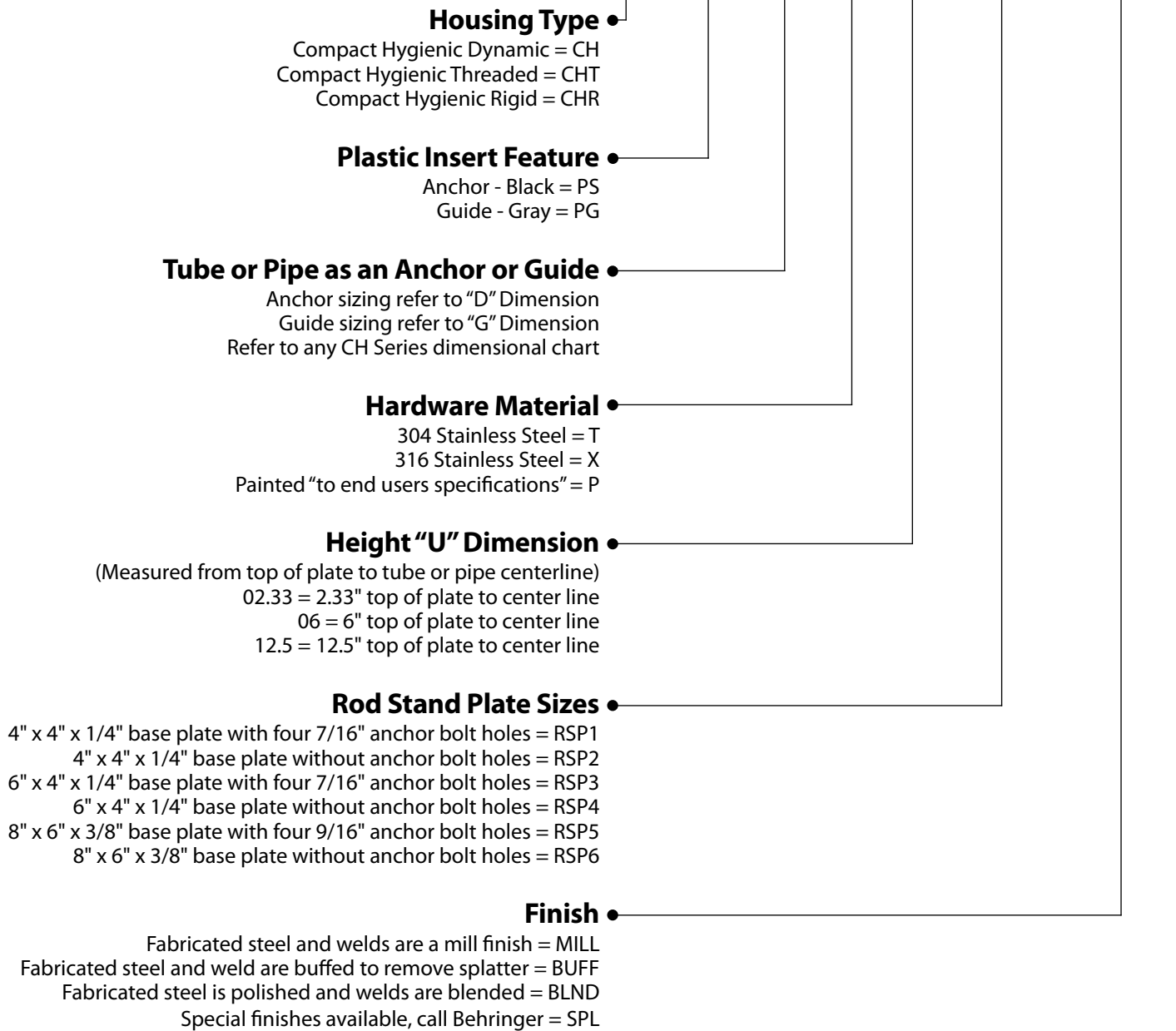
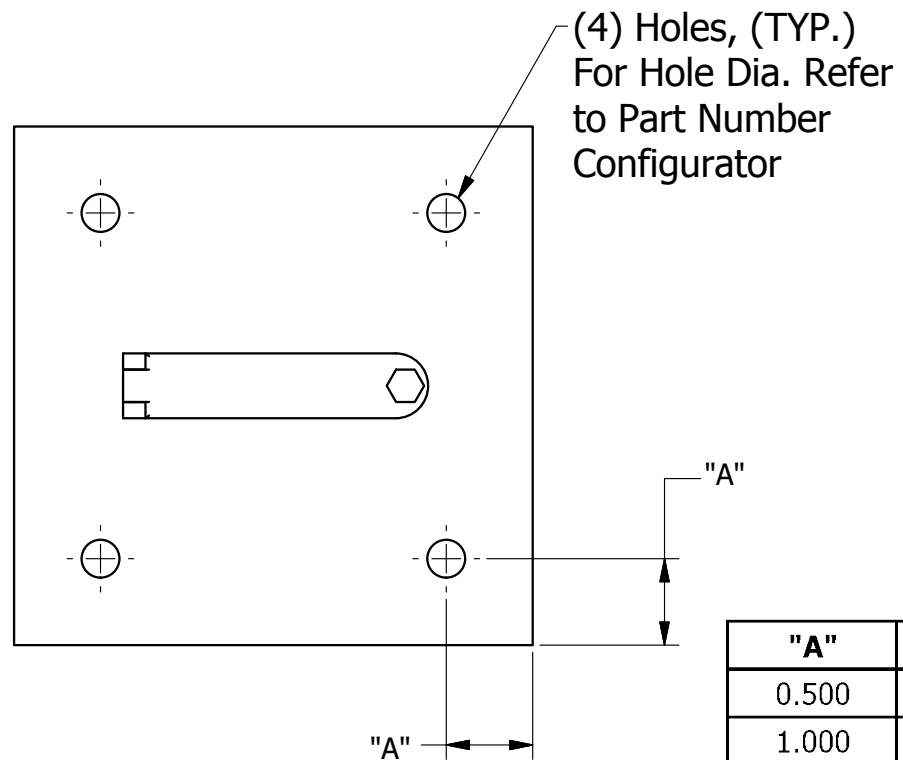
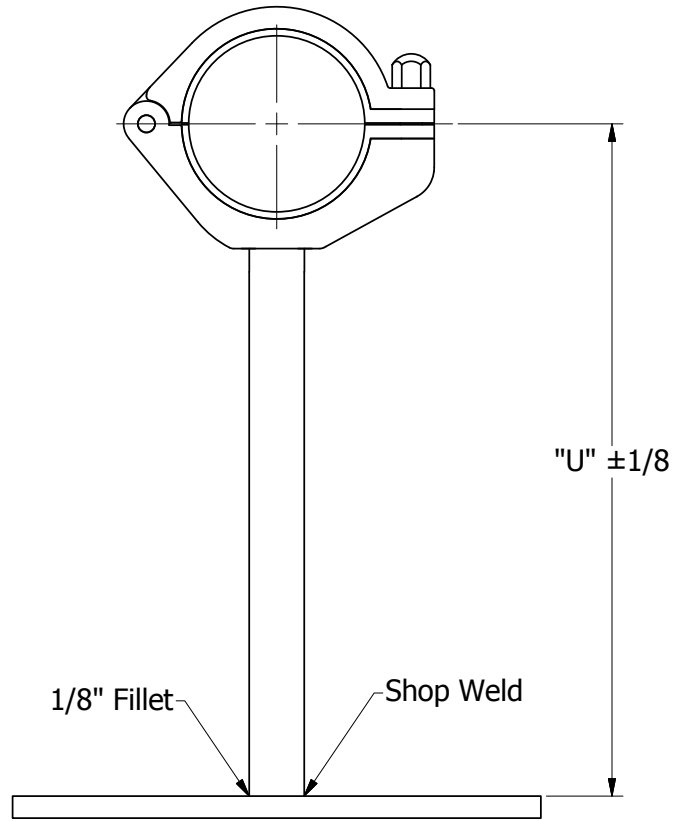

FIG. 224

CH SERIES ROD STAND PLATE



"A"	Model
0.500	RSP1
1.000	RSP3 &5

TELESCOPIC ADJUSTING STANCHION - HANG MOUNT[About](#) | [Part Number Configurator](#) | [Schematic](#) | [Photos](#)**Telescopic Adjusting Stanchion - Hang Mount**

Hanger Stanchion with square or round tube cut to specified length. One end of the tube has a capped end with a rod hole. The rod hole is used for telescopic adjustment of the hanger rod. Specify the steel finish and the finish on the weld.

Features: Hole in capped end of tube allows the hanger rod to be manually adjusted for telescopic location of the tube or pipe.

Hardware: 304 Stainless Steel, 316 Stainless Steel

Finish: MILL = Fabricated steel and welds are a mill finish
BUFF = Fabricated steel and weld are buffed to remove splatter
BLND = Fabricated steel is polished and welds are blended

Special finishes and painted stands are available, call Customer Service for price and availability.

225 Telescopic Hang Mount Stanchion - Part Number Configurator

Part Number Example:

S12 - B - SW1 - XXX - T - MILL

S12 - B - SW1 - XXX - T - MILL

Stanchion Length

- 6" = S06
- 12" = S12
- 18" = S18
- 24" = S24
- 36" = S36
- 48" = S48
- 96" = S96

Rod Hole Diameter

- Capped end with 3/8" rod hole = A
- Capped end with 1/2" rod hole = B
- Capped end with 5/8" rod hole = C
- Capped end with 3/4" rod hole = D
- Capped end with 1" rod hole = E
- Capped end with no rod hole = F

Square Tube Size

- 1-1/2" x 1-1/2" x 1/8" square tube = SW1
- 2" x 2" x 1/8" square tube = SW2
- 3" x 3" x 3/16" square tube = SW3

either/or

Round Tube Size

- 1-1/2" SCH 40 round pipe = RW1
- 2" SCH 40 round pipe = RW2
- 3" SCH 40 round pipe = RW3

Base Plate

- no base plate = XXX

Hardware Material

- 304 Stainless Steel = T
- 316 Stainless Steel = X
- Electro-Zinc Plated Carbon = Z
- Carbon Steel = C
- Painted to end users specifications = P

Finish

- Fabricated steel and welds are a mill finish = MILL
- Fabricated steel and weld are buffed to remove splatter = BUFF
- Fabricated steel is polished and welds are blended = BLND
- Special finishes available, call Behringer = SPL

TELESCOPIC ADJUSTING STANCHION - HANG MOUNT

[About](#) | [Part Number Configurator](#) | [Schematic](#) | [Photos](#)

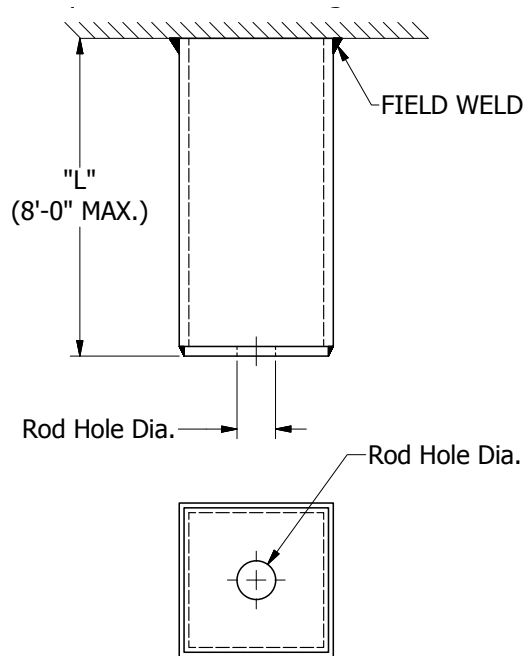
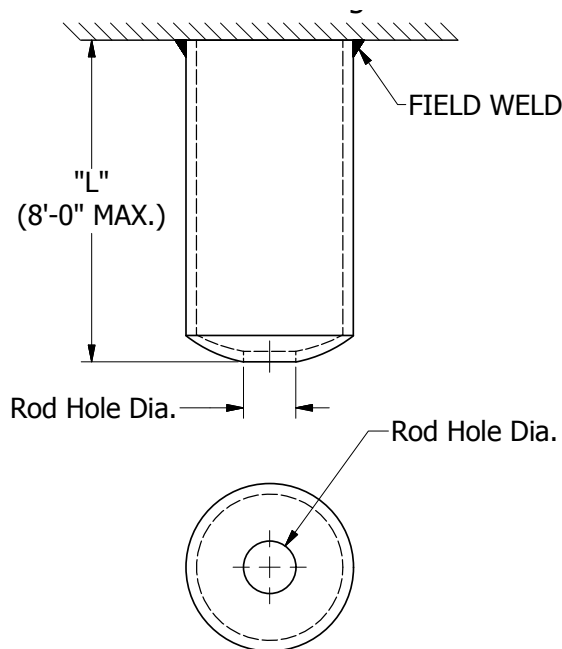
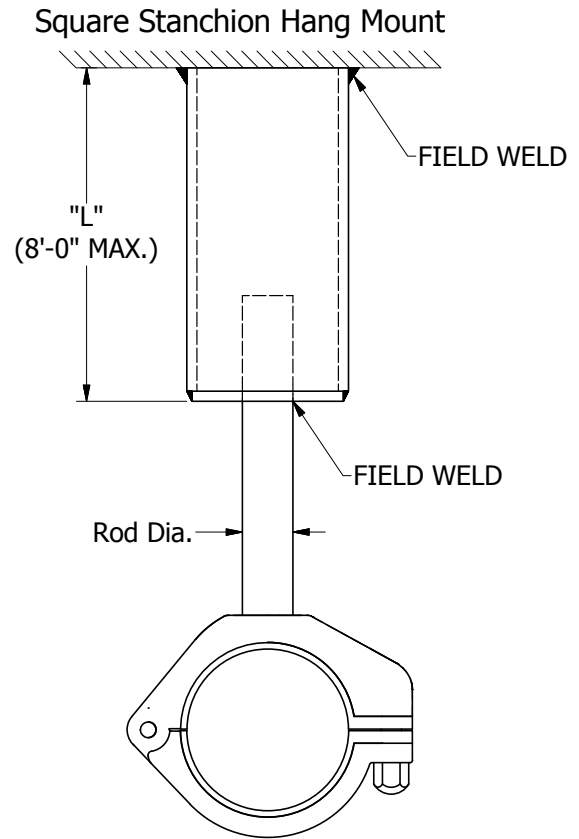
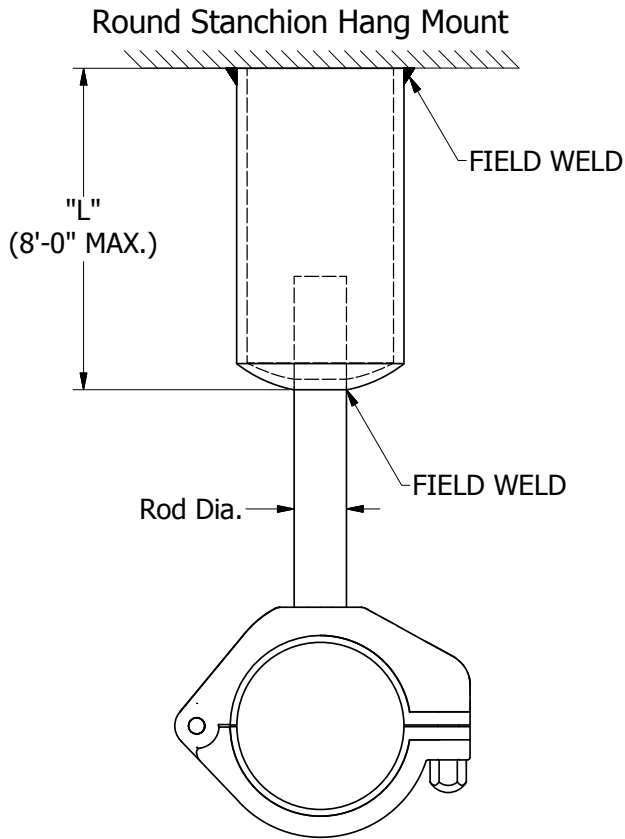

Note: Clamp and Rod Sold Separately

FIG. 225

TELESCOPIC ADJUSTING STANCHION - HANG MOUNT

[About](#) | [Part Number Configurator](#) | [Schematic](#) | [Photos](#)

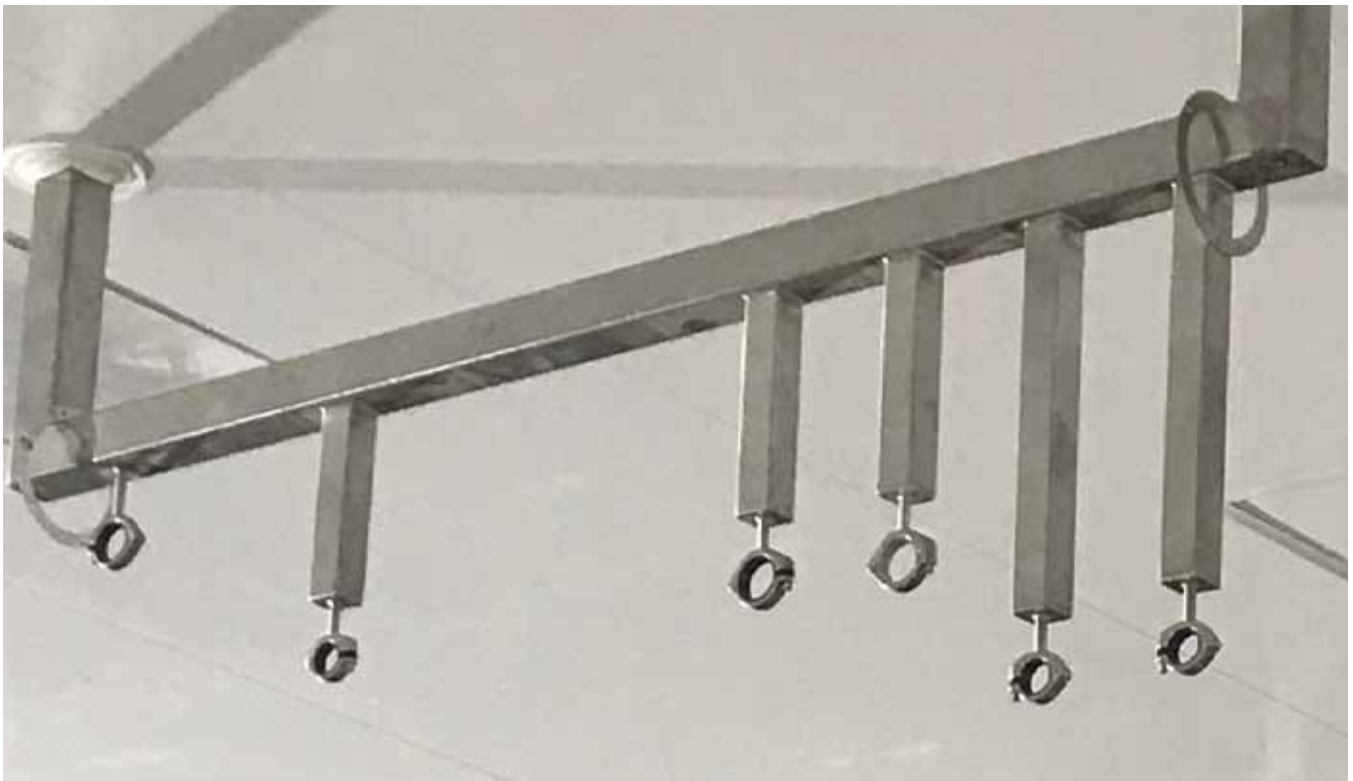
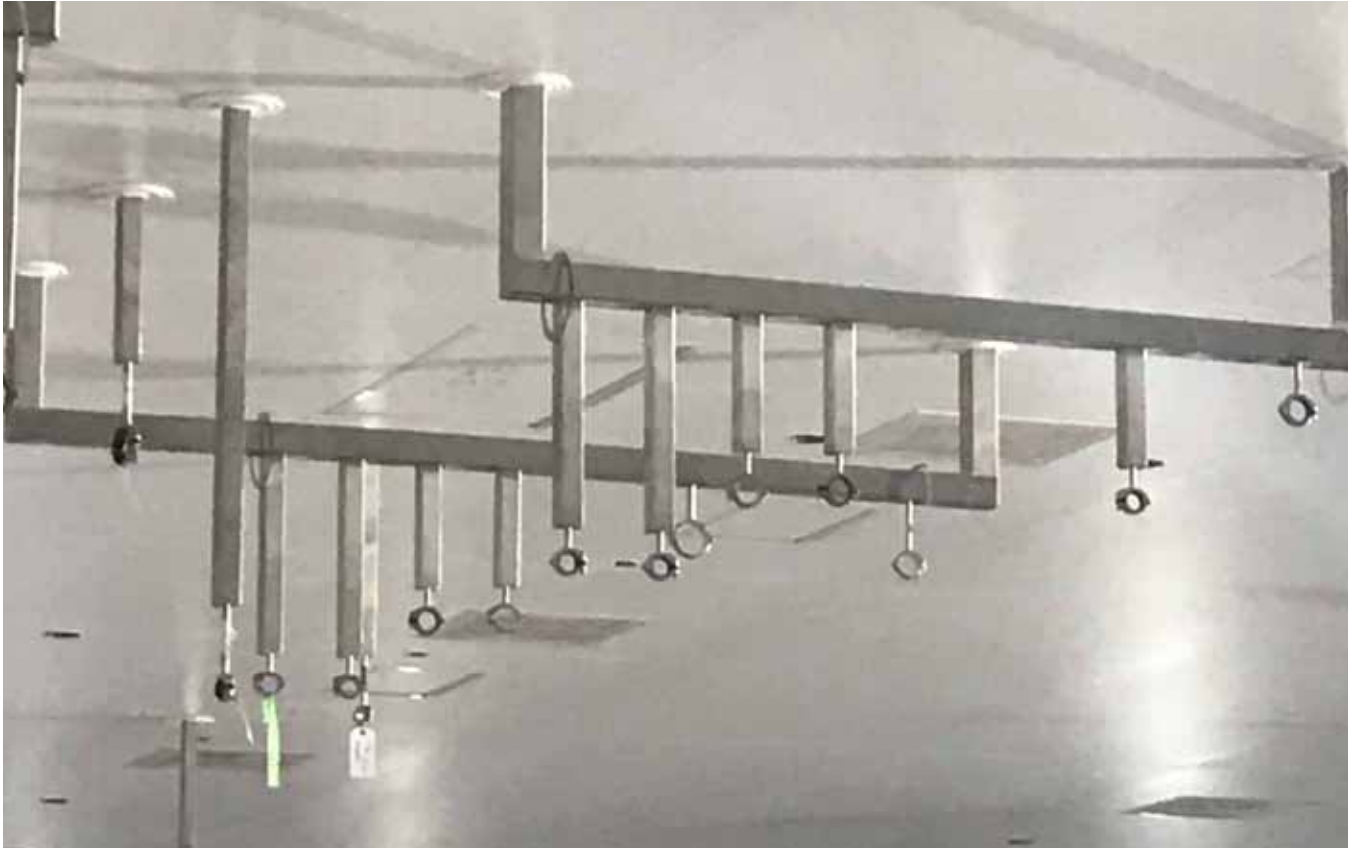

TELESCOPIC ADJUSTING STANCHION - FLOOR MOUNT[About](#) | [Part Number Configurator](#) | [Schematic](#)**Telescopic Adjusting Stanchion - Floor Mount**

One piece Floor Stand with square or round tube cut to specified length. One end of the tube has a capped end with a rod hole. The rod hole is used for telescopic adjustment of the hanger rod. The open end of the tube is welded to a base plate which can be supplied with or without anchor bolt holes. Specify the steel finish and the finish on the weld.

Features: Hole in capped end of tube allows the hanger rod to be manually adjusted for telescopic location of the tube or pipe.

Hardware: 304 Stainless Steel; 316 Stainless Steel, Carbon Steel & Electro-Zinc Plated Carbon Steel

Finish: MILL = Fabricated steel and welds are a mill finish
BUFF = Fabricated steel and weld are buffed to remove splatter
BLND = Fabricated steel is polished and welds are blended

Special finishes and painted stands are available, call Customer Service for price and availability.

Cautionary Note: If using a Dynamic housing as a sliding base support, it is recommended to tack weld the housing once slope has been verified. This will ensure that the base plate remains flat or parallel to the resting surface. This particularly applies to high temperature service lines that will experience thermal cycling.

226 Telescopic Adjusting Stanchion Floor Mount - Part Number Configurator

Part Number Example:

S12 - B - SW1 - BP1 - T - MILL

S12 - B - SW1 - BP1 - T - MILL

Stanchion Length

- 6" = S06 24" = S24
- 12" = S12 36" = S36
- 18" = S18 48" = S48
- 96" = S96

Rod Hole Diameter

- Capped end with 3/8" rod hole = A
- Capped end with 1/2" rod hole = B
- Capped end with 5/8" rod hole = C
- Capped end with 3/4" rod hole = D
- Capped end with 1" rod hole = E
- Capped end with no rod hole = F

Square Tube Size

- 1-1/2" x 1-1/2" x 1/8" square tube = SW1
- 2" x 2" x 1/8" square tube = SW2
- 3" x 3" x 3/16" square tube = SW3

either/or

Round Tube Size

- 1-1/2" SCH 40 round pipe = RW1
- 2" SCH 40 round pipe = RW2
- 3" SCH 40 round pipe = RW3

Base Plate

- 6" x 6" x 3/8" base plate with four 7/16" anchor bolt holes = BP1
- 6" x 6" x 3/8" base plate without anchor bolt holes = BP2
- 8" x 8" x 1/2" base plate with four 9/16" anchor bolt holes = BP3
- 8" x 8" x 1/2" base plate without anchor bolt holes = BP4

Hardware Material

- 304 Stainless Steel = T
- 316 Stainless Steel = X
- Electro-Zinc Plated Carbon = Z
- Carbon Steel = C
- Painted to end users specifications = P

Finish

- Fabricated steel and welds are a mill finish = MILL
- Fabricated steel and weld are buffed to remove splatter = BUFF
- Fabricated steel is polished and welds are blended = BLND
- Special finishes available, call Behringer = SPL

Round Stanchion Floor Mount

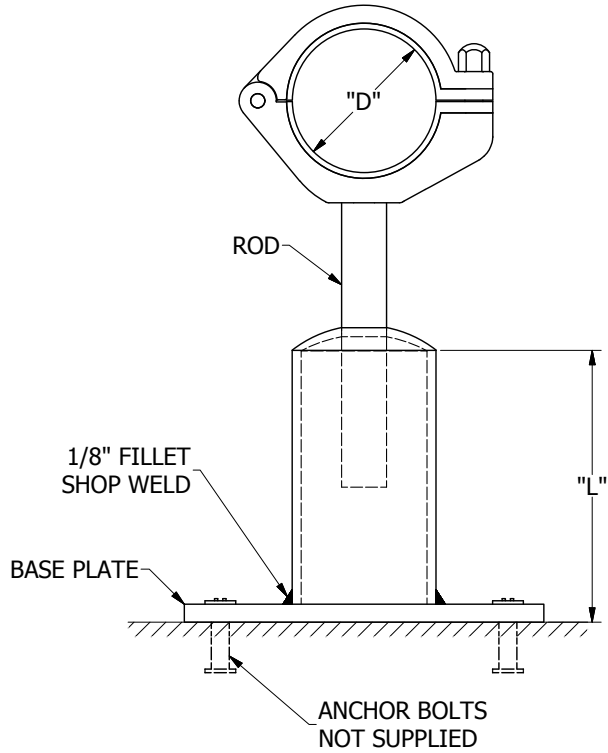

Square Stanchion Floor Mount

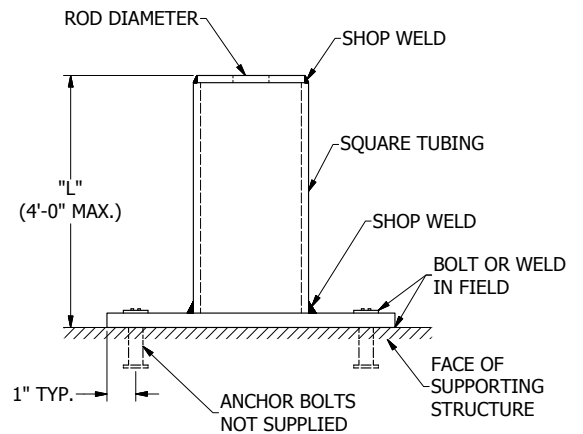
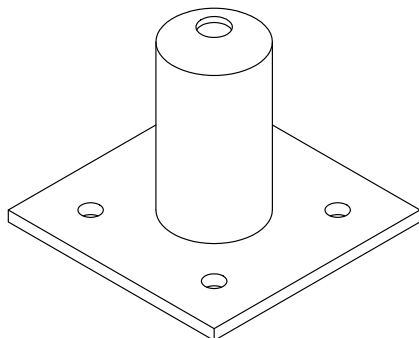
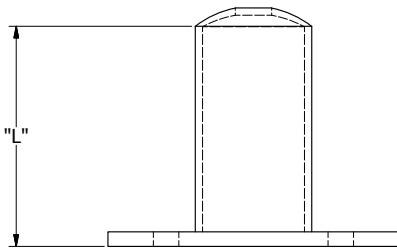
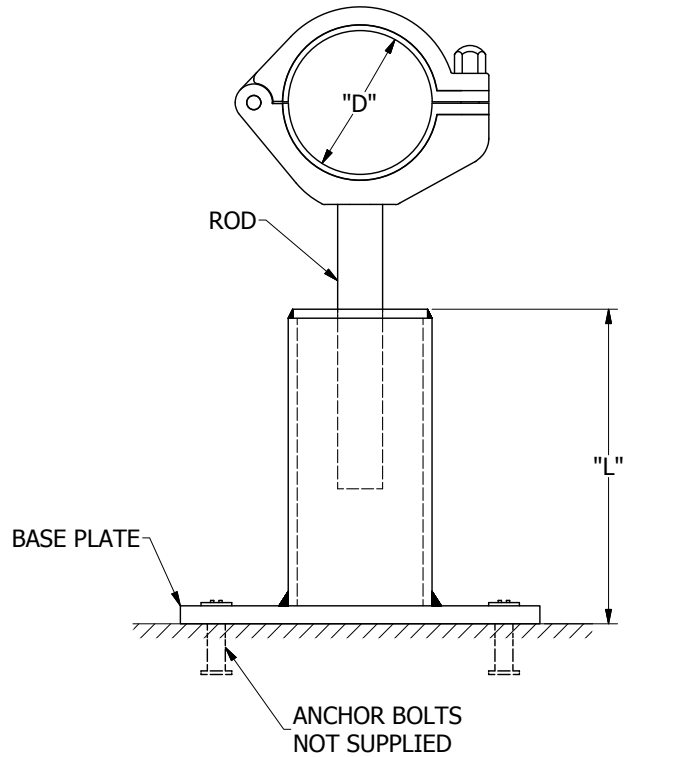

Note: Clamp and Rod Sold Separately



CH Rigid Height Adjuster

- Fine tune slope for process lines to achieve full drainability
- Adjustment range of up to 1" above and below midpoint setting, providing a total of 2" of travel distance
- Installers will not need to use temporary supports, therefore, reducing installation time
- Components of adjuster are captive so will not come apart
- Economical option in comparison to standard stanchions, where permitted
- Convenient wrench flats for easy field adjustment
- If needed, a simple tack weld will secure the elevation
- Designed to be used with our CHT rounded supports with a threaded connection
- **ASME BPE** Compliant – no exposed threads, drainable geometry



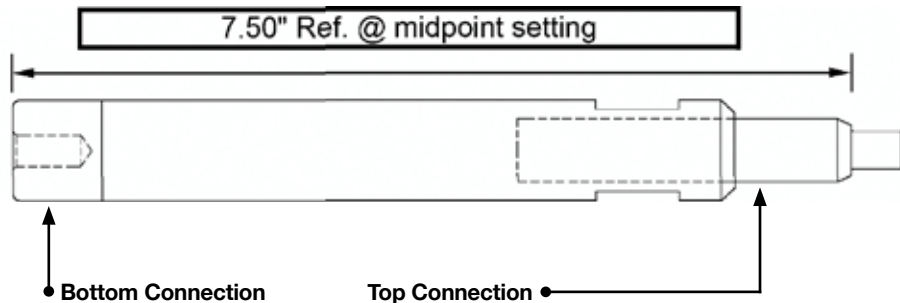
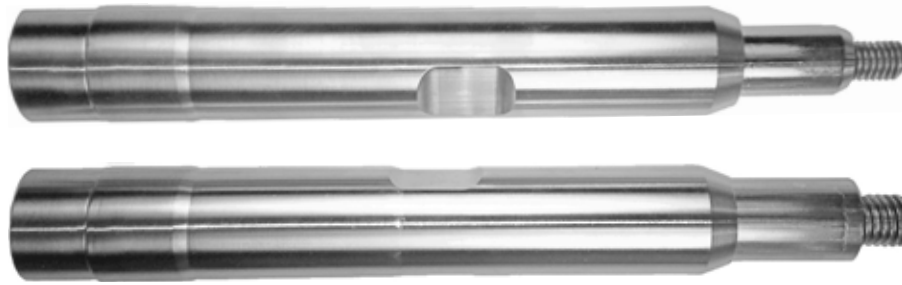

038F	3/8-16 UNC
050F	1/2-13 UNC
075F	3/4-10 UNC

038M	3/8-16 UNC	Group 1-7 CHT
050M	1/2-13 UNC	Group 8-8A CHT
075M	3/4-10 UNC	Group 9 CHT

Part Number Configuration

Adjuster Type	-	Bottom Connection	-	Top Connection	-	Material
CHADJ		038F		038M		T=304
		050F		050M		X=316
		075F		075M		

Inventory Items

CHADJ-038F-038M-T
CHADJ-050F-038M-T
CHADJ-050F-050M-T
CHADJ-075F-075M-T

Rigid Height Adjuster Support Assembly with Integral Stanchion Cap

Contact factory for specifications and pricing.





CH Dynamic Height Adjuster

- Dynamic style offers both height and slope adjustment after installation
- Saves time on piping installation-No need to install temporary supports
- Fine tune slope for process lines to achieve full drainability
- 1-1/2" of total travel length (3/4" length of adjustment from mid-point setting)
- Assembly includes CH Dynamic housing
- Shorter offset dimension than standard CH Height Adjuster
- Economical option in comparison to standard stanchions, where permitted
- Wrench flats for easy adjustment adjacent to the tube support
- Internal O-Ring seal to keep out any fluids
- Captive design for safety
- **ASME BPE** Compliant-No exposed threads, drainable geometry



Part Number: CH-HA-T-1

The Height Adjustment Coupling:

This coupling is designed for fine tuning of the elevation on hangers to get the proper slope for drainability. It can be used in conjunction with our stanchions or by themselves. The hygienic design of this coupling incorporates an integral o-ring seal and has a travel length of ½ in. Socket weld connection (Size to suit).



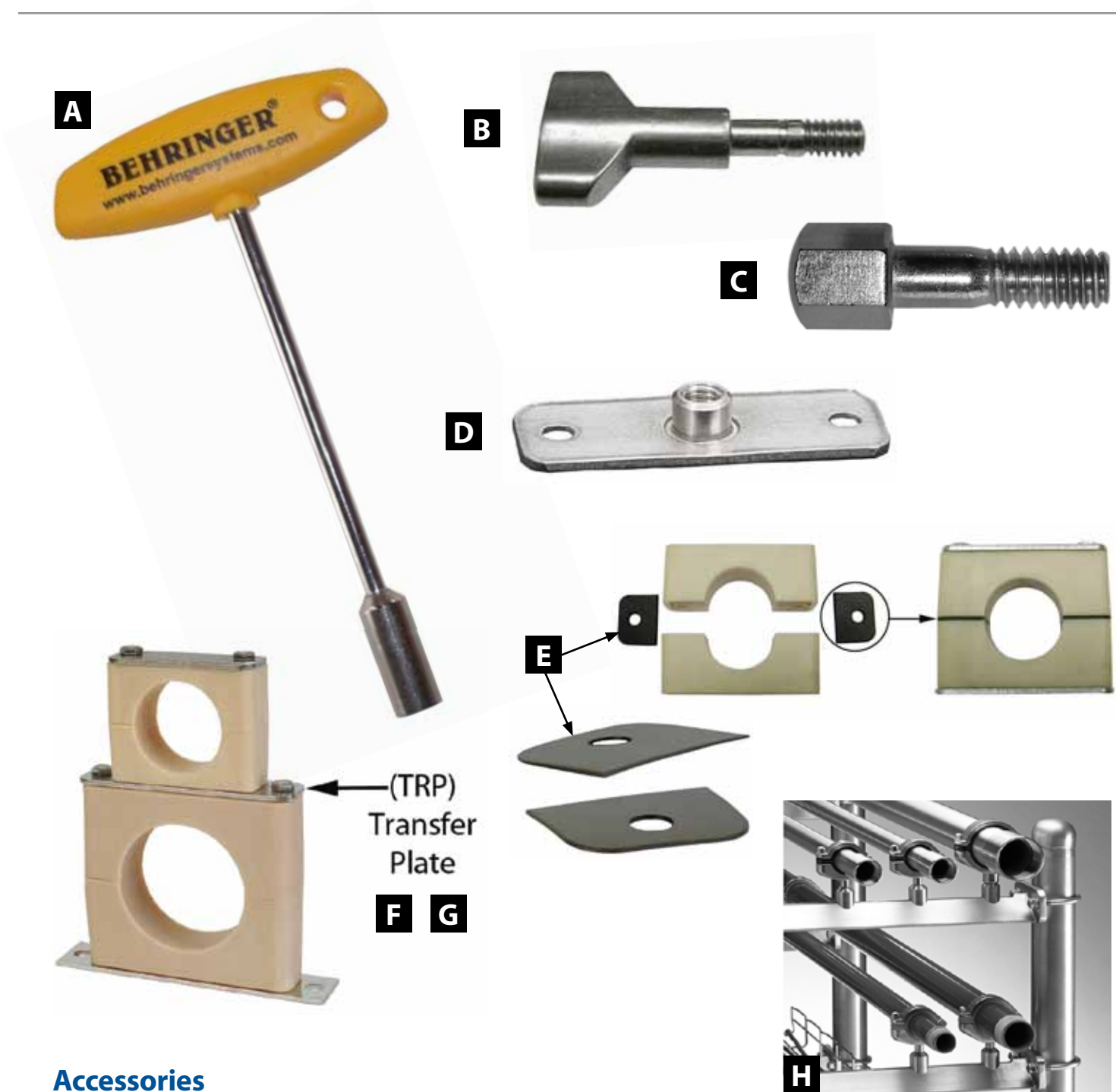

(TRP)
Transfer
Plate

Accessories

A	T-Handle Nut Driver	CHTOOL
B	Wing Bolt	CWBT-01
C	Acorn Bolt	CABX-01
D	Swivel Plate (Ceiling Mount Plate)	SB-SWV-06-T
E	Fig 207-Thermal Expansion Guide (TEG)	SB-TEG-06-S-150
F	Transfer Plate (Group 7 to 6)	SB-TRP-06-T-706
G	Transfer Plate (Group 6 to 3)	SB-TRP-06-T-603
H	OCAL Inserts	Conduit/Electrical Inserts



Technical Appendix

Proper Slope for Drainability	84
Recommended Mounting Practices	85
Thermal Expansion	85
Material Properties	86
Surface Finishing for Metal Parts.....	87
Slope Conversion Chart	88
Shear Force Diagram	89
Spacing of Hangers	90

Proper Slope for Drainability

Process piping must be installed to achieve:

- Continuous slope for drainability—offset any deflection present with slope.
- Adequate spacing of supports to avoid pooling of liquids
- Minimum slope per ASME BPE Standard:
 - Table SD-2.4.3.1-1 Slope Designations for Gravity-Drained Lines
 - GSD1 1/16"/ft. minimum (5mm/m)
 - GSD2 1/8"/ft. minimum (10mm/m) (min. recommended by ASME for product-contact lines)
 - GSD3 1/4"/ft. minimum (20mm/m)
 - GSD0 Line slope not required
- Slope measurements should be taken with a calibrated digital level or protractor per ASME BPE Non-Mandatory Appendix C
- Added support in proximity to any concentrated loads
- Supports at each change of direction
- Corrosion resistance
- Materials compatible with the chemical, thermal, and physical performance requirements of each application

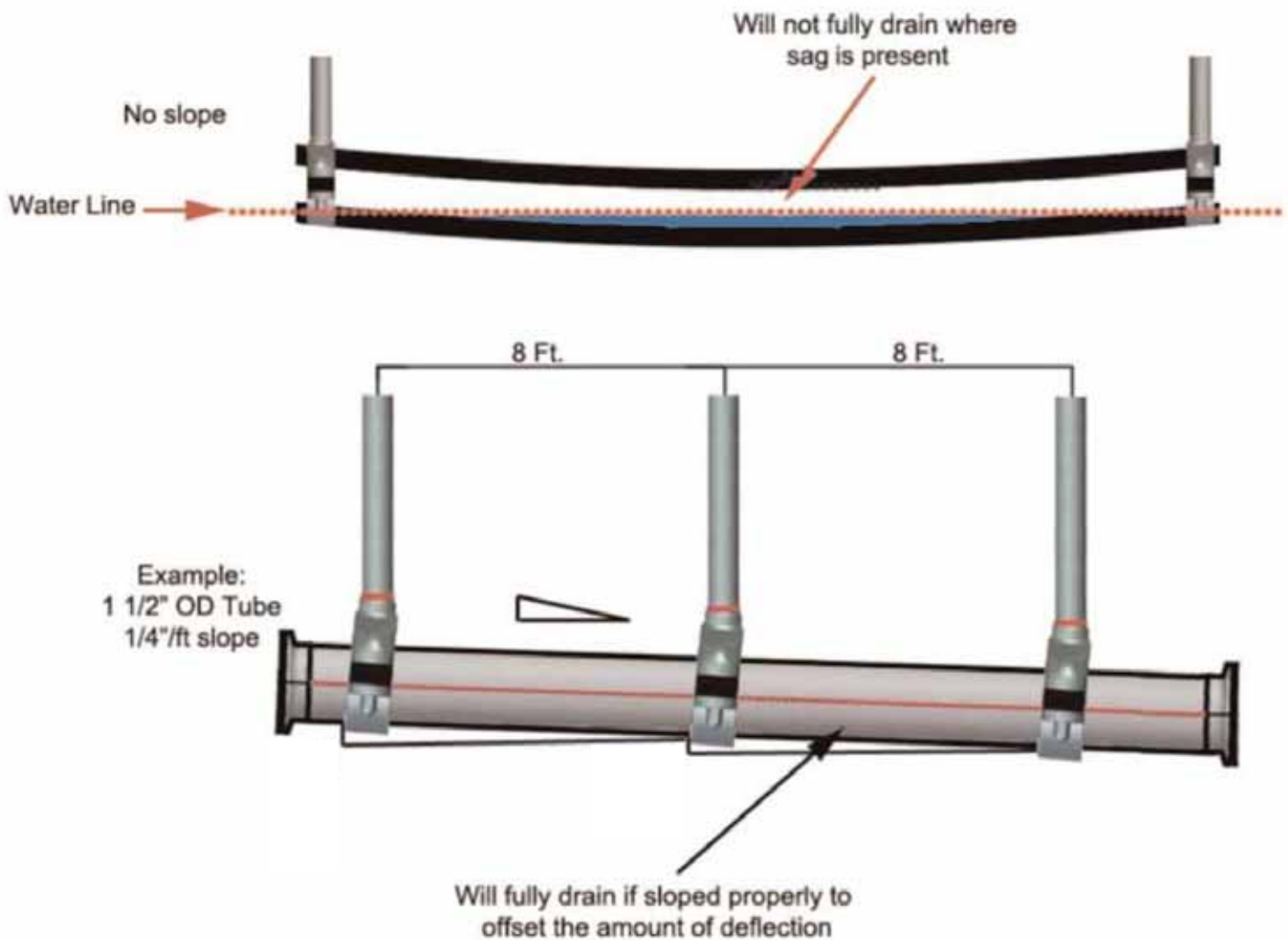

Recommended Mounting Practices



Bends

Behringer recommends that supports and hangers be installed in close proximity to each change in direction of piping, with consideration of pipe movement due to thermal expansion and use of anchor and guide inserts to facilitate intended pipe movements.



Concentrated Loads

Behringer recommends that supports and hangers be installed as close as possible to any concentrated loads, such as valves, instrumentation, and other process components.

It may be necessary to install on both sides of certain loads to reduce deflection and ensure proper continuous slope for drainability.

Thermal Expansion

- Anchoring systems should be designed to accommodate piping motion including thermal expansion.
- Proper selection and positioning of anchors and guides to facilitate thermal cycling of the piping without causing structural damage or cause process components to misalign at mechanical joints.
- Anchor - An anchor is a rigid device used to prevent all pipe displacement at the point of application. Anchors are used to fix selected points on a piping system in order to control forces, moments, and movement in each section of the total pipe run.
- Guide - A guide is a device used to permit pipe movement in a predetermined direction while preventing undesirable movement in other directions. Guides are used to control piping movement, provide lateral pipe stability, control sway, and ensure proper alignment at expansion joints and loops. The guide allows free axial movement of the pipe/tube while maintaining proper alignment and elevation for drainability.
- Enlarging the ID dimension of the CH Series Polyethersulfone insert by .040" (Groups 1-5) and 0.050" (Groups 6-9) turns a gripping support "Anchor" into a "Guide". Behringer stocks both anchor and guide inserts for OD tube, pipe, and copper tube sizes. See part number configuration for more information. Guide inserts are also available for the Smooth Bore Series (See Fig. 207 in accessories).



Smooth Bore Inserts

General Information			Thermal Properties	
Plastic Insert Material	Part # Code	Color	Intermittent Exposure	Continuous Exposure
Polypropylene	PP	Blue	-22° to + 212°F (-30° to + 102° C)	-22° to + 194°F (-30° to + 90° C)
Santoprene	SP	Beige	-40° to + 302°F (-40° to + 150° C)	-40° to + 275°F (-40° to + 135° C)
Polyethersulfone	PS	Black	-50° to + 320°F (-45° to + 160° C)	-50° to + 320°F (-45° to + 160° C)
Polyethersulfone**	PS	Black	-50° to + 392°F (-45° to + 200° C)	-50° to + 392°F (-45° to + 200° C)
Zeotherm	ZT	Black	-40° to + 350°F (-40° to + 175° C)	-40° to + 300°F (-40° to + 150° C)
High Density Polyethylene*	NN	White	-58° to + 180°F (-50° to + 82° C)	-58° to + 175°F (-50° to + 79° C)
High Temp Nylon*	HT	Black	-40° to + 350°F (-40° to + 177° C)	-40° to + 260°F (-40° to + 127° C)

* NN & HT inserts available in group 8 & 9 sizes only.

** Note: Inventory will be transitioning from Polysulfone (PS) to Polyethersulfone (PESU) material starting Feb 2019. Part numbers will remain the same. Orders will be fulfilled using a FIFO plan until fully converted.

CH Series Inserts

General Information			Thermal Properties	
Plastic Insert Material	Part # Code	Color	Intermittent Exposure	Continuous Exposure
Polyethersulfone**	PS	Black	-50° to + 392°F (-45° to + 200° C)	-50° to + 392°F (-45° to + 200° C)
Polyethersulfone**	PG	Gray	-50° to + 392°F (-45° to + 200° C)	-50° to + 392°F (-45° to + 200° C)
Polysulfone	PS	Black	-50° to + 320°F (-45° to + 160° C)	-50° to + 320°F (-45° to + 160° C)
Polysulfone	PG	Gray	-50° to + 320°F (-45° to + 160° C)	-50° to + 320°F (-45° to + 160° C)

**Note: Inventory will be transitioning from Polysulfone (PS) to Polyethersulfone (PESU) beginning October 2018. Part numbers will remain the same.

Chemical Properties	Resistant to a wide range of Chemicals. Please contact Behringer for Product Data Sheets.
Mechanical Properties	

Surface Finishing for Metal Parts

In addition to the standard surface finish, alternative finishes are available on request



Mill Finish



Brushed



Blended Weld

TABLE 1			TABLE 2			TABLE 3			
Slope by Percentage (%) (most accurate)			Slope by Degrees (°) (second accurate)			Slope by inches/foot (least accurate)			
Percent (%)	Degrees (°)	inches/foot	Degrees (°)	Percent (%)	inches/foot	inches/foot	decimal eq	Percent (%)	Degrees (°)
0.1	0.057	0.012	0.1	0.175	0.021	1/64	0.016	0.130	0.075
0.2	0.115	0.024	0.2	0.349	0.042	1/32	0.031	0.260	0.149
0.3	0.172	0.036	0.3	0.524	0.063	3/64	0.047	0.391	0.224
0.4	0.229	0.048	0.4	0.698	0.084	1/16	0.063	0.521	0.298
0.5	0.286	0.060	0.5	0.873	0.105	5/64	0.078	0.651	0.373
0.6	0.344	0.072	0.6	1.047	0.126	3/32	0.094	0.781	0.448
0.7	0.401	0.084	0.7	1.222	0.147	7/64	0.109	0.911	0.522
0.8	0.458	0.096	0.8	1.396	0.168	1/8	0.125	1.042	0.597
0.9	0.516	0.108	0.9	1.571	0.189	9/64	0.141	1.172	0.671
1.0	0.573	0.120	1.0	1.746	0.209	5/32	0.156	1.302	0.746
1.1	0.630	0.132	1.1	1.925	0.231	11/64	0.172	1.432	0.821
1.2	0.688	0.144	1.2	2.100	0.252	3/16	0.188	1.563	0.895
1.3	0.745	0.156	1.3	2.275	0.273	13/64	0.203	1.693	0.970
1.4	0.802	0.168	1.4	2.450	0.294	7/32	0.219	1.823	1.044
1.5	0.859	0.108	1.5	2.625	0.315	15/64	0.234	1.953	1.119
1.6	0.917	0.192	1.6	2.800	0.336	1/4	0.250	2.083	1.193
1.7	0.974	0.204	1.7	2.975	0.357	5/16	0.313	2.604	1.492
1.8	1.031	0.216	1.8	3.150	0.378	3/8	0.375	3.125	1.790
1.9	1.088	0.228	1.9	3.325	0.399	7/16	0.438	3.646	2.088

Shear Force

Shear Force Testing was conducted under controlled conditions and with manufacturers recommended bolt torque. Actual Shear Forces may vary due to specific process conditions such as temperature, tube surface roughness, uneven load conditions and presence of line shock and/or vibration.

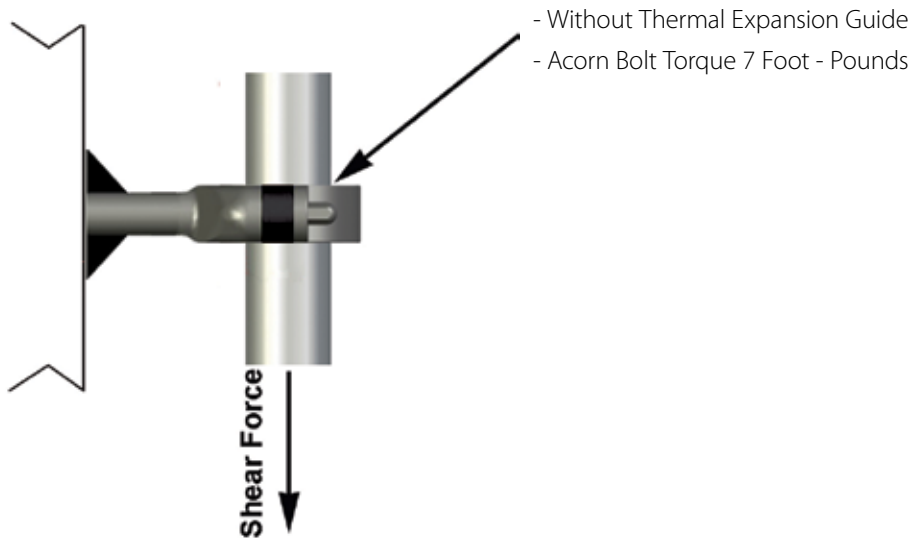
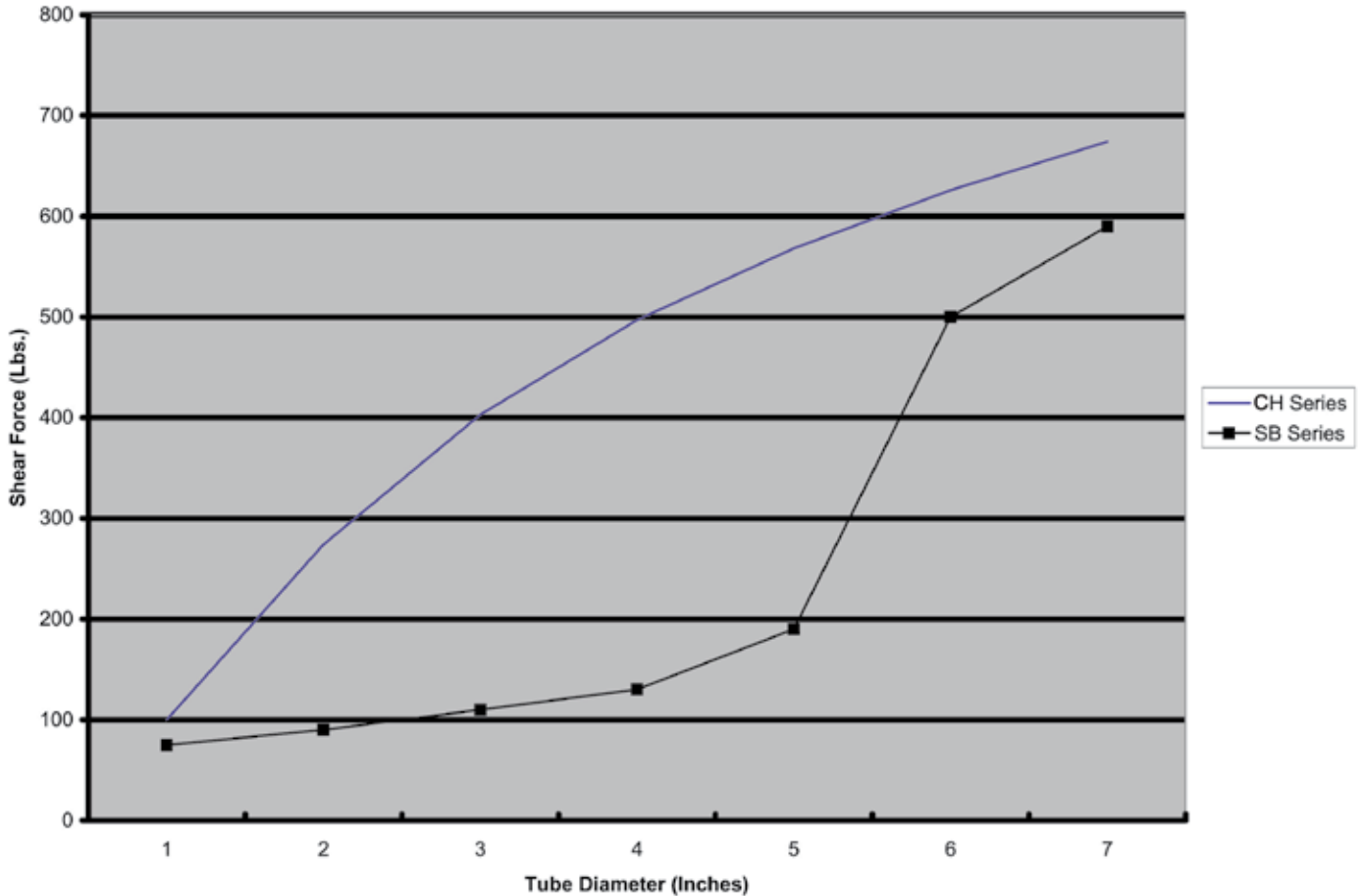

SPACING OF HANGERS

Hangers and/or supports shall be spaced as far apart as economically possible with due consideration to assure that the sag of the pipe between supports is within limits that will permit drainage and also avoid excessive bending stresses from concentrated loads such as valves and in-line equipment. Contractor shall use the maximum recommended spacing between pipe support specified below. Spacing indicated below may differ from that listed in MSS SP-69. Additional hangers may be necessary to adequately support concentrated loads such as valves, flanges, or instruments.

STEEL PIPE HANGER SPACING:

PIPE SIZE (IN)	MAXIMUM SPACING (FT)
1/2" & 3/4"	4
1"	5
1-1/2" & 2"	10
3"	12
4" -16"	16

COPPER TUBING HANGER SPACING (includes schedule 10 pipe):

TUBING SIZE (IN)	MAXIMUM SPACING (FT)
3/8" - 3/4"	6
1" - 1-1/4"	8
1-1/2" - 3"	10
4" - 8"	12

STAINLESS STEEL SANITARY TUBING HANGER SPACING:

TUBING SIZE (IN)	MAXIMUM SPACING (FT)
1/2" - 3/4"	4
1"	5
1-1/2"	6
2"	8
2-1/2" - 3"	10
4"	12
6"	14

PLASTIC PIPING:

Support in accordance with manufacturers recommendations.

BEHRINGER[®]

For more information on Behringer Pipe Supports for industrial applications, visit our website:

www.behringersystems.com

Or call us at +1 (973) 948-0226

Your local stocking distributor:

Behringer Corporation
17 Ridge Road
Branchville, NJ 07826
Tel: +1 (973) 948-0226
Fax: +1 (973) 948-2562
email: sales@behringersystems.com
web: www.behringersystems.com