

BEHRINGER®



Pipe Supports

For Industrial Applications



Introduction

Thank you for choosing Behringer, the world's leading manufacturer of Pipe and Tube supports. Behringer has been manufacturing pipe clamps and support systems for over 40 years, and has developed a reputation in the industrial and sanitary markets that is second to none. We have made developments and product improvements over the years both strengthening and broadening our product offering. This is evident in the breadth of our line and ability to accommodate new applications and designs. You can count on Behringer for all of your clamping requirements.

Product

Behringer Industrial Pipe and Tube Supports have natural vibration-dampening characteristics. This is important in pressure piping in order to reduce vibration, noise, and shock. This will effectively protect the system and its sensitive components from the damaging effects of these adverse system byproducts typically found in pressure piping systems.

Behringer offers several different series and within each series there are many different configurations available. We offer options for mounting such as welding, bolting, rail and strut mounting, double, and group mounting, etc. Behringer always welcomes a challenge, and would be happy to work with you to design a product that is custom-tailored to your application. This is where many of our developments are first generated, and helps to further progress the complexity of our product. Challenge us with your requirements.

Guarantee

Behringer Corporation, hereinafter called the "MANUFACTURER", guarantees that this product shall be free from defects in workmanship and materials. THIS GUARANTEE IS IN LIEU OF ALL OTHER GUARANTEES EITHER EXPRESSED OR IMPLIED, INCLUDING GUARANTEES FOR FITNESS FOR PURPOSE INTENDED. The MANUFACTURER'S liability is limited to the replacement of any materials which, after inspection by the MANUFACTURER at its sole option, are found to be defective. The MANUFACTURER will honor only those claims that are presented to it within one hundred eighty (180) days of the delivery of the materials to the purchaser. The MANUFACTURER SPECIFICALLY DISCLAIMS ANY AND ALL LIABILITY FOR CONSEQUENTIAL DAMAGES. The MANUFACTURER shall not be liable for any damages which arise out of the misuse or abuse of the products.



Applications

Behringer clamps are used in many different types of applications ranging from low pressure lubrication and water systems to high pressure hydraulic and process systems. Anywhere that there are pipes, tubes, or hoses are viable applications for Behringer clamps. Behringer clamps are used in the following markets and applications most frequently.

Mobile Equipment
Mining Equipment
Offshore and Marine Applications
Shipbuilding
Instrumentation
Nuclear
General Construction
Electrical/Mechanical Contracting
Process Piping
Pharmaceutical/Biotechnology
Food and Dairy
Beverage

Power Generation
Pulp and Paper
Industrial Hydraulics
Power Units
Agricultural Equipment
OEM Machinery

Assistance

Behringer Corporation has a competent and highly skilled staff of inside sales and customer service personnel available to assist you with any of your needs. Behringer can be reached in the following ways.

Post Mail: Behringer Corporation
17 Ridge Road
Branchville, NJ 07826
Telephone: +1 (973) 948-0226
Fax: +1 (973) 948-2562
Email: sales@behringersystems.com

Our regular business hours are Monday through Friday, 8AM - 5 PM Eastern Time. For after-hours service, please contact your regional sales manager.

Please Read

The information contained in this document is provided as an aid in properly selecting products and/or options. It is intended to be used by technically experienced users for general reference only. The supplier assumes no responsibility or liability for the accuracy or completeness of this document, as well as results obtained by the use of this information. Due to the variety of possible operating conditions, it is highly recommended that the user make their own tests to determine the safety and suitability of all products and combinations thereof. The user is solely responsible for final determination of such conditions.

Table of Contents



	<u>Page</u>
Pipe Clamp Selection	2-3
Pipe Clamp Series Specifications	4-5
Standard Series Pipe Clamps	
Clamp Pair Selection, Part Numbers, and Dimensions	6
Securing Plate Selection and Dimensions	7
Rail and Strut Mounting Options	8
Hardware Selection and Dimensions	9
Complete Assembly Ordering Code	10
Ordering Examples	11
Heavy Series Pipe Clamps	
Clamp Pair Selection, Part Numbers, and Dimensions	12
Securing Plate Selection and Dimensions	13
Hardware Selection and Dimensions	14
Rail and Strut Mounting Options	15
Complete Assembly Ordering Code	16
Ordering Examples	17
Twin Series Pipe Clamps	
Clamp Pair Selection, Part Numbers and Dimensions	18
Hardware Selection and Dimensions	19
Rail and Strut Mounting Options	20
Complete Assembly Ordering Code	21
Ordering Examples	22
Heavy-4 Series Pipe Clamps	
Clamp Pair Selection, Part Numbers and Dimensions	23
Hardware Selection and Dimensions	24
Complete Assembly Ordering Code & Ordering Examples	25
Saddle Series Pipe Clamps	
Long Saddle U-Bolt Clamp	26
Short Saddle U-Bolt Clamp	27
Cushioned Clamping System	
Cushioned Clamping System	28
Technical Appendix	
Material Properties Technical Data	29
Complete Clamp Dimensional Drawings	30-31
Tightening Torques and Maximum Loads	32
Recommended Spacing	33

Pipe Clamp Selection

Behringer's pipe clamps are available with many different mounting configurations and arrangements. In choosing a pipe clamp, there are five main required pieces of information; series, size, clamp pair material, hardware material, and mounting/hardware configuration.

Series Selection

In order to select the proper clamp, the first thing that must be determined is the series of clamp to be used. Refer to the series specification on pages 4-5 to see what clamp series are available, as well as the technical characteristics of those series. The most important factors to be considered are the operating pressure of the line to be secured, the weight being supported, and the dynamic load. Other considerations include size, environment, and application. For example, a 1" pipe for a hydraulic system operating at 2,000 psi would typically require the use of the standard series, but the heavy series may be selected if it will be required to support the weight of a large filter or other system component. Maximum weight loads and shearing forces can be found in the technical appendix. Also, the heavy series might be selected rather than the standard series if the line is on a piece of mining or mobile equipment that may see a very high amount of impact with other equipment or materials such as stones and metals. In Fig.1 below you can see the suggested operating pressures by series. These suggested values take into consideration the shock and vibration that a typical hydraulic system operating at these pressures can deliver.

Fig. 1: General Pressure Guidelines by Series

Clamp Series	Suggested Operating Pressure
Standard	up to 2000 psi
Heavy	5000 psi for Single Heavy/10,000 psi for Double
Twin	up to 1500 psi
Heavy-4	5000 psi for Single Heavy/10,000 psi for Double

Size

The next important factor in the selection of the pipe clamp is the size of the line to be secured. Behringer clamps use a modular group size that consists of multiple OD sizes being available within the same group. Clamps are listed as pipe or tube sizes. The difference is in the standard measurements used to rate pipe and tube sizes. Pipe is rated by the inside diameter, and will have a larger outside diameter because of the wall thickness. For example, a 1 inch pipe has an OD of 1.315. This is a standard pipe OD size and is consistent of all hydraulic pipe, regardless of schedule. Tubing, on the other hand, is rated by the outside diameter. Therefore, a 1 inch tube will have an OD of 1.00 in. This is important in determining the size of the pipe clamp that will be selected. Also, the size may determine the series of clamp selected. For example, a low pressure line operating at 1,500 psi that is 6 inch pipe size is not available in the Standard Series, therefore the Heavy Series must be used.

Clamp Pair Material

The clamp pair material is the next thing that should be selected. Behringer's clamp pairs are offered in different materials; Polypropylene (PP), Santoprene (SP), Aluminum (AL), HDPE (NN), and High Temperature Cast Nylon (HT). The single most important determining factor of clamp pair material is operating temperature. The temperature ratings and other important specifications can be found in the technical appendix. Some materials are not available in all sizes or all series. Refer to the specific clamp pair selection charts from each series to see what is available in the required size. Other considerations for materials are compatibility with the environment and for aesthetic reasons, color.

Hardware Material

Once you have determined the series of pipe clamp and the size that is required, the next step is to determine the hardware materials that you will require. In the series selection pages, you will see that each series has a standard hardware material type. See Fig. 2 for standard hardware choices. The standard hardware is either plain carbon steel or zinc-plated steel. All Behringer clamps that are zinc-plated use a trivalent blue zinc plating, which is more environmentally friendly than typical hexavalent zinc plating, and is RoHS compliant. In addition to the standard hardware choices, Behringer offers stainless steel in 2 grades from stock. AISI 304 Stainless Steel (A2 - 1.4301/1.4305) is used in applications where stainless steel is required. This may be in an outside environment, because of chemical compatibility reasons, or because of requirements from the FDA or other regulatory committee. AISI 316 Ti Stainless Steel (A4 - 1.4401/1.4571) is a high grade stainless steel. The 316 Stainless is used in applications where it will come in contact with salt water or air with a high salt concentration such as offshore or marine applications.

Fig. 2: Standard Hardware Material by Series

Clamp Series	Code	Material
Standard	Z	Clear Zinc-Plated Steel
Heavy	C	Plain Carbon Steel
Twin	Z	Clear Zinc-Plated Steel
Heavy-4	C	Plain Carbon Steel

Pipe Clamp Selection

Mounting / Hardware Configuration

Behringer offers a multitude of mounting configurations and arrangement styles. Clamps can be mounted to support structure by either welding, bolting, rail-mounting, unistrut mounting, or stanchion and special securing plates. In addition, clamps can be stacked on top of each other, suspended from threaded rods, or any number of double and group positions can be made on multiple clamp weld plates, called Group Weld Plates (GRW). These options are not available for every series. Please check the ordering code for available mounting and hardware configurations. See below for examples of these mounting types.



Weld Mounting [STW, SWP, TWP]

Clamps are supplied with a weld plate for welding directly to the support structure. This is the most common form of clamp mounting, and is available in all series of pipe clamps. It is typically used with a cover plate and bolts, and is a commonly stocked item.

Standard Series:	STW
Heavy Series:	SWP / DWP
Twin Series:	TWP
Heavy 4 Series:	SWP / DWP



Rail Mounting [RAL / RCN]

Rail mounting makes installation of multiple lines of different group sizes an easy task. All clamps within one series can be mounted directly to a single channel using rail nuts that are designed for that rail. Behringer also makes proprietary rails that can accept the weld plates rather than the rail nuts. The rail uses are as follows.

RAL-0	Standard and Twin Series Clamps with RCN-0 (standard) / RCN-T0 (twin)
RAL-1	Standard and Twin Series with STW RCN-1 (standard) / RCN-4 (twin)
RAL-2	Heavy Series Clamps with SWP (H3-H5)
RAL-3	Heavy Series Clamps with SWP (H6)
RAL-4	Heavy Series Clamps with RCN



Bolt Mounting with Base Plates [BAP]

Clamps are supplied with a base plate for applications where the clamp cannot be welded into position. This is commonly used to mount the clamps to non-metallic surfaces such as wood or drywall. However, base plates can be welded into position if required. Base plates are available in the standard series and heavy series.



Strut Mounting (UCN)

Behringer clamps can also be supplied with strut nuts (UCN) for mounting to standard strut channel. The new spring-loaded nuts are adaptable to any strut channel that is 1-5/8" wide. The depth of the channel is not important, as the UCN clips attach with a spring loaded tension on the top of the channel. Unistrut adaptation is available for all series of pipe clamps.



Multiple Clamp Weld Plates [DOW, GRW]

For multiple lines, Behringer offers double weld plates or group weld plates. The double weld plates create a double clamp that allows for the convenience of welding only one plate, but the strength and durability of using standard series hardware with individual clamp halves and 4 hex bolts. Group weld plates can accommodate between 3-10 positions, depending on the application. This is beneficial for keeping a tightly regimented center distance on the piping or tubing where multiple lines are run along the same plane. For both the double and group weld plates, all clamps to be fitted to the same plate must be within the same hardware group size.



Stacking Kits

Stacking kits consist of a set of clamp halves, stacking bolts, and a safety plate. A stacking kit is everything that is needed to take an existing clamp and make it one level taller. You use the hardware from the existing clamp; remove the cover plate, clamp halves, and hex bolts from the existing clamp, insert the stacking kit onto the bottom fixture (weld plate, rail nuts, etc...), and then replace the existing clamp hardware on top. Multiple stacking kits can be added to increase the number of clamps stacked on top of each other. Stacking kits are available in all series.

Pipe Clamp Series Specifications

Vibration-Dampening Pipe Clamps

Behringer's vibration-dampening pipe clamps are manufactured in different series for use in many different applications. The core range of pipe clamps encompasses Standard Series, Heavy Series, Heavy-4 Series, and Twin Series. They meet ASTM, Shipbuilding, Nuclear, Coast Guard, and other specifications.



Standard Series Pipe Clamps

Range: 0.25 in. (6.2 mm) through 4 in. (102 mm) OD

Pressure: 2,000 psi

Material: Zinc-plated, 304SS, 316SS, Carbon Steel

Clamp Halves: Polypropylene, Santoprene, Aluminum

Standard series pipe clamps can withstand the shock and vibration that a hydraulic system operating at up to 2,000 psi can deliver. Standard hardware is zinc-plated steel, unless otherwise noted. Also available from stock are 304 SS and 316 SS hardware. The standard series is offered in a multitude of configurations, such as weld-mounting, bolt-mounting, rail-mounting, stacking, double weld-mounting, and group weld-mounting. Many other options are possible with existing hardware, and custom arrangements are always a welcomed challenge.



Heavy Series Pipe Clamps

Range: 0.25 in. (6.3 mm) through 8.625 in. (219 mm)

Pressure: 5,000 to 10,000 psi

Material: Plain Carbon Steel, 304SS, 316SS, Zinc Plated

Clamp Halves: Polypropylene, Santoprene, Aluminum

Heavy series pipe clamps can withstand the shock and vibration that a hydraulic system operating at up to 5,000 psi can deliver. With the use of the Double Heavy design, lines with operating pressure of up to 10,000 psi can be accommodated. Standard hardware material is un-plated carbon steel. Also available are 304 SS and 316 SS, as well as zinc-plated hardware. The heavy series can be mounted using a weld plate, baseplate, rails, and stacking kits. Many other options are possible with existing hardware, and custom arrangements are always a possibility.



Twin Series Pipe Clamps

Range: 0.25 in. (6.3 mm) through 1.66 in. (42 mm)

Pressure: 1,500 psi

Material: Zinc Plated, 304SS, 316SS, Plain Carbon Steel

Clamp Halves: Polypropylene, Santoprene

The Twin Series is an excellent choice where multiple lines are required, while keeping a close center distance between the lines. Twin series pipe clamps can withstand the shock and vibration that a hydraulic system operating at up to 1,500 psi can deliver. Twin Series hardware material is zinc-plated steel. Also available from stock are 304 SS and 316 SS hardware. The twin series can be mounted using a weld plate, rails, and stacking kits. Many other options are possible with existing hardware, and custom arrangements are always an option.



Heavy-4 Series Pipe Clamps

Range: 8.625 in. (219 mm) through 30 in. (762 mm) OD

Pressure: 5,000 psi to 10,000 psi

Material: Un-plated Carbon Steel, 304SS, 316SS, Zinc-Plated

Clamp Halves: Polypropylene
Others on request

Behringer's patented Heavy-4 Series pipe clamps are unrivaled in design and performance. Our clamps feature a unique 4-segmented plastic design which retains dimensional accuracy, resists stress and impact, absorbs vibration, and accomplishes a strong plastic-to-metal contact interface. This segmented plastic design is complemented by substantial steel support hardware.

Heavy-4 Series pipe clamps can withstand the shock and vibration that a hydraulic system operating at up to 5,000 psi can deliver, and with the use of the double heavy design they can accommodate lines with pressures up to 10,000 psi. Standard hardware is a low carbon steel. Also available are 304 SS and 316 SS as well as zinc-plated hardware. The Heavy-4 Series is only offered as a weld-mounted clamp.

Pipe Clamp Series Specifications

Other Pipe Clamps

Behringer also manufactures other clamping components and hardware. The Cushion Clamps mount low pressure lines to commonly found strut channel. Plastic saddle clamps and U-bolts are commonly used on large diameter low pressure piping. Behringer has roots in the metal fabrication industry, and we can easily manufacture customer-specific fabricated metal or injection molded products. We currently manufacture many other items for OEMs that are specially designed for that specific customer. We work closely with key personnel in the research and design stages, and can make prototypes in a very short time. Let us know what we can do for you.



Cushioned Pipe Clamps

Range: 0.25 in. (6.2 mm) through 6.625 in. (168 mm) OD

Pressure: Low pressure

Material: Zinc-Plated, 304SS, 316 SS

Clamp Insert: Thermoplastic Elastomer

Behringer's cushioned clamps are designed for low pressure applications such as conduit, water, waste, and other non or low pressure lines. They easily mount to standard strut channels that are available in almost every industrial and many mobile applications. The standard hardware material is zinc-plated steel. Also available are 304 SS and 316 SS hardware. The cushion is manufactured from a thermoplastic elastomer material that is designed to reduce vibration and noise, while providing constant reliability in operating temperatures to 275 degrees F.



Saddle Series Pipe Clamps

Range: 0.84 in. (21 mm) through 30 in. (762 mm)

U-Bolt Material: Zinc Plated, 304SS, 316SS,

Saddle Material: Polypropylene, UHMW

The Saddle Series pipe clamps consist of a heavy duty plastic saddle and a U-bolt with 4 hex nuts. The saddle series allows for movement due to vibrations and thermal expansion and contraction. The plastic saddle eliminates the metal-to-metal contact of the piping on the support structure, preventing costly damage to pipe installations. Behringer's Saddle Series clamps are typically used in shipbuilding, offshore and marine vessels, chemical plants, or wherever large diameter low pressure piping is installed. Behringer's saddle clamps are available in 2 different designs; Long Saddle and Short Saddle. The Long Saddle (shown above) extends past the u-bolt legs, and has holes for the legs to be inserted into. The Short Saddle does not extend to the u-bolts, and sits on the support structure or is held in place with location pins.

Custom Pipe Clamps



Range: Any

Pressure: Any

Material: Any

Clamp Insert: Any

Customization is an easy task for Behringer's vast experience in custom metal fabrication and injection molding. If you have ideas about a custom-made product, we can easily and quickly take concepts and turn them into prototypes and ultimately production items. Behringer currently manufactures custom products for major OEM manufacturers in the mobile, offshore, industrial, and construction markets. Some custom items are a variation of a standard item, and others are completely different from our cataloged items. Let Behringer work for you to help resolve any of your fastening or clamping requirements.

Standard Series Pipe Clamps

Behringer's clamp pairs are available in different materials and incorporate a modular insert by group size. Standard Series pipe clamps are available in sizes from 1/4 in. (6.35mm) through 4.5 in. (114mm) outside diameter sizes, and various materials such as polypropylene, Santoprene, and aluminum.



Group 0

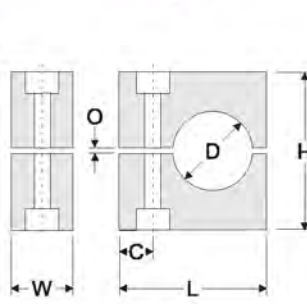

Groups 1-7A

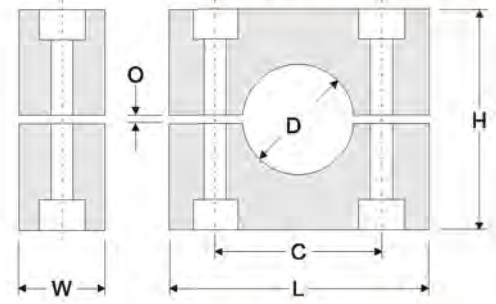

Clamp Pair Material Codes (*)			
P	[PP] Polypropylene Black Color	S	[SP] Santoprene Beige Color
		A	[AL] Aluminum Aluminum Color

Clamp Pair Selection and Part Numbers

Behringer Group	Size	Metric OD (mm)	Imperial OD (Inch)	L	C	H	O	W	Weight Ea.	Ribbed Inside Clamp Pair (See material for *)
0	1/4 OD Tube	6.4	0.250	1.125 in. (28.6 mm)	0.375 in. (9.5 mm)	1.110 in. (28.2 mm)	0.031 in. (0.8 mm)	1.219 in. (31 mm)	0.02 lbs	ST-CLH-00-*-025
	3/8 OD Tube	9.5	0.375							ST-CLH-00-*-038
	1/8 OD Tube	10.0	0.405							ST-CLH-00-*-041
	1/2 OD Tube	12.7	0.500							ST-CLH-00-*-050
	5/8 OD Tube	16.0	0.625							ST-CLH-00-*-062
1	1/4 OD Tube	6.4	0.250	1.375 in. (35 mm)	0.790 in. (20 mm)	1.080 in. (27.4 mm)	0.031 in. (0.8 mm)	1.219 in. (31 mm)	0.03 lbs	ST-CLH-01-*-025
	8 mm OD	8.0	0.315							ST-CLH-01-*-032
	3/8 OD Tube	9.5	0.375							ST-CLH-01-*-038
	1/8 Pipe	10.0	0.405							ST-CLH-01-*-041
	12 mm	12.0	0.472							ST-CLH-01-*-047
2	3/8 OD Tube	9.5	0.375	1.625 in. (42 mm)	1.020 in. (26 mm)	1.280 in. (32.5 mm)	0.031 in. (0.8 mm)	1.219 in. (31 mm)	0.04 lbs	ST-CLH-02-*-038
	1/2 OD Tube	12.7	0.500							ST-CLH-02-*-050
	1/4 Pipe	13.7	0.540							ST-CLH-02-*-054
	15 mm	15.0	0.591							ST-CLH-02-*-059
	5/8 OD Tube	16.0	0.625							ST-CLH-02-*-062
	3/8 Pipe	17.1	0.675							ST-CLH-02-*-068
3	3/8 OD Tube	9.5	0.375	1.875 in. (48 mm)	1.300 in. (33 mm)	1.380 in. (35.1 mm)	0.031 in. (0.8 mm)	1.219 in. (31 mm)	0.05 lbs	ST-CLH-03-*-038
	18 mm	18.0	0.709							ST-CLH-03-*-070
	3/4 OD Tube	19.0	0.750							ST-CLH-03-*-075
	20 mm	20.0	0.790							ST-CLH-03-*-079
	1/2 Pipe	21.3	0.840							ST-CLH-03-*-084
	7/8 OD Tube	22.2	0.875							ST-CLH-03-*-087
	1 OD Tube	25.4	1.000							ST-CLH-03-*-100
4	3/4 Pipe	26.7	1.050	2.250 in. (57 mm)	1.580 in. (40 mm)	1.625 in. (42 mm)	0.031 in. (0.8 mm)	1.219 in. (31 mm)	0.06 lbs	ST-CLH-04-*-105
	1 1/8 OD Tube	28.6	1.125							ST-CLH-04-*-112
	30 mm	30.0	1.181							ST-CLH-04-*-118
5	1 1/8 OD Tube	28.6	1.125	2.750 in. (70 mm)	2.050 in. (52 mm)	2.375 in. (60 mm)	0.031 in. (0.8 mm)	1.219 in. (31 mm)	0.11 lbs	ST-CLH-05-*-113
	1 1/4 OD Tube	32.0	1.250							ST-CLH-05-*-125
	1 Pipe	33.4	1.315							ST-CLH-05-*-132
	35 mm	35.0	1.378							ST-CLH-05-*-138
	1 1/2 OD Tube	38.1	1.500							ST-CLH-05-*-150
	40 mm	40.0	1.575							ST-CLH-05-*-157
	1 5/8 OD Tube	41.3	1.625							ST-CLH-05-*-163
	1 1/4	42.2	1.660							ST-CLH-05-*-166
6	1 3/4 OD Tube	44.5	1.750	3.375 in. (86 mm)	2.600 in. (66 mm)	2.625 in. (67 mm)	0.031 in. (0.8 mm)	1.219 in. (31 mm)	0.12 lbs	ST-CLH-06-*-175
	1 1/2 Pipe	48.3	1.900							ST-CLH-06-*-190
	2 OD Tube	50.8	2.000							ST-CLH-06-*-200
7	2 1/4 OD Tube	57.2	2.250	5.000 in. (127 mm)	4.250 in. (108 mm)	4.375 in. (111 mm)	0.031 in. (0.8 mm)	1.219 in. (31 mm)	0.41 lbs	ST-CLH-07-*-225
	2 Pipe	60.3	2.375							ST-CLH-07-*-238
	2 1/2 OD Tube	63.5	2.500							ST-CLH-07-*-250
	2 1/2 Pipe	73.0	2.875							ST-CLH-07-*-288
	3 OD Tube	76.2	3.000							ST-CLH-07-*-300
	3 Pipe	88.9	3.500							ST-CLH-07-*-350
7A	4 OD Tube	102.0	4.000	5.750 in. (146 mm)	4.948 in. (126 mm)	4.828 in. (123 mm)	0.031 in. (0.8 mm)	1.219 in. (31 mm)	0.39 lbs	ST-CLH-7A-*-400
	4 Pipe	114.0	4.500							ST-CLH-7A-*-450

www.behringer.com

Standard Series Pipe Clamps

Securing Plate Selection and Dimensions

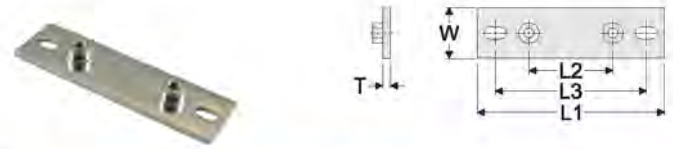
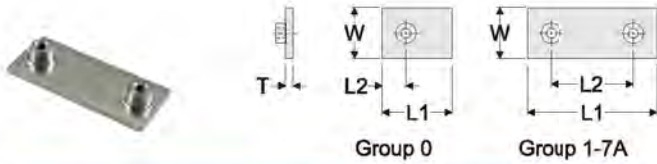

Single Weld Plate [STW]							
Grp.	Order Number	L1	L2	W	T	Thread	Weight
0	ST-STW-00-*	1.188 in. (30 mm)	0.370 in. (9 mm)	1.223 in. (31 mm)	0.120 in. (3 mm)	1/4 - 20 UNC M6	0.06 lbs
1	ST-STW-01-*	1.510 in. (38 mm)	0.790 in. (20 mm)	1.223 in. (31 mm)	0.120 in. (3 mm)	1/4 - 20 UNC M6	0.07 lbs
2	ST-STW-02-*	1.740 in. (44 mm)	1.020 in. (26 mm)	1.223 in. (31 mm)	0.120 in. (3 mm)	1/4 - 20 UNC M6	0.08 lbs
3	ST-STW-03-*	2.020 in. (51 mm)	1.300 in. (33 mm)	1.223 in. (31 mm)	0.120 in. (3 mm)	1/4 - 20 UNC M6	0.10 lbs
4	ST-STW-04-*	2.300 in. (58 mm)	1.580 in. (40 mm)	1.223 in. (31 mm)	0.120 in. (3 mm)	1/4 - 20 UNC M6	0.11 lbs
5	ST-STW-05-*	2.770 in. (70 mm)	2.050 in. (52 mm)	1.223 in. (31 mm)	0.120 in. (3 mm)	1/4 - 20 UNC M6	0.13 lbs
6	ST-STW-06-*	3.320 in. (84 mm)	2.600 in. (66 mm)	1.223 in. (31 mm)	0.120 in. (3 mm)	1/4 - 20 UNC M6	0.15 lbs
7	ST-STW-07-*	5.02 in. (128 mm)	4.250 in. (108 mm)	1.223 in. (31 mm)	0.120 in. (3 mm)	1/4 - 20 UNC M6	0.21 lbs
7A	ST-STW-7A-*	5.776 in. (147 mm)	4.948 in. (126 mm)	1.223 in. (31 mm)	0.120 in. (3 mm)	1/4 - 20 UNC M6	0.27 lbs

***Materials:** Z Zinc Plated Steel (Standard Material)
 T AISI 304 Grade Stainless Steel (A2 - 1.4301/1.4305)
 X AISI 316 Grade Stainless Steel (A4 - 1.4401/1.4571)
 C Unplated Carbon Steel (Standard Material)

Threads: Omit As ordered above, the weld plates have standard UNC Thread
 -MET By adding the "-MET" designation after the material designation above, the threads are M6 Metric Thread

Base Plate [BAP]								
Grp.	Order Number	L1	L2	L3	W	T	Thread	Weight
0	ST-BAP-00-*	-	-	-	-	-	-	-
1	ST-BAP-01-*	3.000 in. (76 mm)	0.790 in. (20 mm)	2.295 in. (58 mm)	1.223 in. (31 mm)	0.120 in. (3 mm)	1/4 - 20 UNC M6	0.13 lbs
2	ST-BAP-02-*	3.302 in. (84 mm)	1.020 in. (26 mm)	2.550 in. (65 mm)	1.223 in. (31 mm)	0.120 in. (3 mm)	1/4 - 20 UNC M6	0.14 lbs
3	ST-BAP-03-*	3.500 in. (89 mm)	1.300 in. (33 mm)	2.825 in. (72 mm)	1.223 in. (31 mm)	0.120 in. (3 mm)	1/4 - 20 UNC M6	0.16 lbs
4	ST-BAP-04-*	3.813 in. (97 mm)	1.580 in. (40 mm)	3.085 in. (78 mm)	1.223 in. (31 mm)	0.120 in. (3 mm)	1/4 - 20 UNC M6	0.16 lbs
5	ST-BAP-05-*	4.250 in. (108 mm)	2.050 in. (52 mm)	3.500 in. (89 mm)	1.223 in. (31 mm)	0.120 in. (3 mm)	1/4 - 20 UNC M6	0.19 lbs
6	ST-BAP-06-*	4.875 in. (124 mm)	2.600 in. (66 mm)	4.125 in. (105 mm)	1.223 in. (31 mm)	0.120 in. (3 mm)	1/4 - 20 UNC M6	0.20 lbs
7	ST-BAP-07-*	6.500 in. (165 mm)	4.250 in. (108 mm)	5.750 in. (146 mm)	1.223 in. (31 mm)	0.120 in. (3 mm)	1/4 - 20 UNC M6	0.27 lbs
7A	ST-BAP-07A-*	7.240 in. (184 mm)	4.948 in. (126 mm)	6.450 in. (164 mm)	1.223 in. (31 mm)	0.120 in. (3 mm)	1/4 - 20 UNC M6	0.35 lbs

***Materials:** Z Zinc Plated Steel (Standard Material)
 T AISI 304 Grade Stainless Steel (A2 - 1.4301/1.4305)
 X AISI 316 Grade Stainless Steel (A4 - 1.4401/1.4571)
 C Unplated Carbon Steel (Standard Material)

Threads: Omit As ordered above, the weld plates have standard UNC Thread
 -MET By adding the "-MET" designation after the material designation above, the threads are M6 Metric Thread

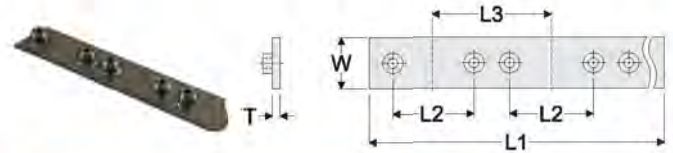
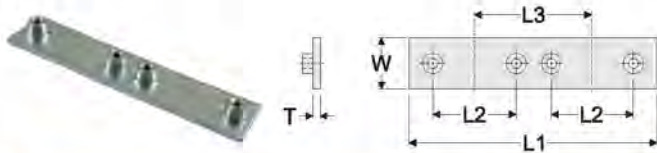

Double Weld Plate [DOW]								
Grp.	Order Number	L1	L2	L3	W	T	Thread	Weight
0	ST-DOW-00-*	-	-	-	-	-	-	-
1	ST-DOW-01-*	3.000 in. (76 mm)	0.790 in. (20 mm)	1.510 in. (38 mm)	1.223 in. (31 mm)	0.120 in. (3 mm)	1/4 - 20 UNC M6	0.16 lbs
2	ST-DOW-02-*	3.500 in. (89 mm)	1.020 in. (26 mm)	1.740 in. (44 mm)	1.223 in. (31 mm)	0.120 in. (3 mm)	1/4 - 20 UNC M6	0.17 lbs
3	ST-DOW-03-*	4.000 in. (102 mm)	1.300 in. (33 mm)	2.020 in. (51 mm)	1.223 in. (31 mm)	0.120 in. (3 mm)	1/4 - 20 UNC M6	0.19 lbs
4	ST-DOW-04-*	4.630 in. (119 mm)	1.580 in. (40 mm)	2.300 in. (58 mm)	1.223 in. (31 mm)	0.120 in. (3 mm)	1/4 - 20 UNC M6	0.24 lbs
5	ST-DOW-05-*	5.630 in. (143 mm)	2.050 in. (52 mm)	2.770 in. (70 mm)	1.223 in. (31 mm)	0.120 in. (3 mm)	1/4 - 20 UNC M6	0.26 lbs
6	ST-DOW-06-*	6.880 in. (175 mm)	2.600 in. (66 mm)	3.320 in. (84 mm)	1.223 in. (31 mm)	0.120 in. (3 mm)	1/4 - 20 UNC M6	0.30 lbs
7	ST-DOW-07-*	10.220 in. (260 mm)	4.250 in. (108 mm)	5.145 in. (131 mm)	1.223 in. (31 mm)	0.120 in. (3 mm)	1/4 - 20 UNC M6	0.45 lbs
7A	ST-DOW-07A-*	11.690 in. (297 mm)	4.948 in. (126 mm)	5.688 in. (144 mm)	1.223 in. (31 mm)	0.120 in. (3 mm)	1/4 - 20 UNC M6	0.56 lbs

***Materials:** Z Zinc Plated Steel (Standard Material)
 T AISI 304 Grade Stainless Steel (A2 - 1.4301/1.4305)
 X AISI 316 Grade Stainless Steel (A4 - 1.4401/1.4571)
 C Unplated Carbon Steel (Standard Material)

Threads: Omit As ordered above, the weld plates have standard UNC Thread
 -MET By adding the "-MET" designation after the material designation above, the threads are M6 Metric Thread

Group Weld Plate [GRW]								
Grp.	Order Number	L1	L2	L3	W	T	Thread	Weight
0	N/A	-	-	-	-	-	-	-
1	ST-GRW-01-XXX	C/F	0.790 in. (20 mm)	1.510 in. (38 mm)	1.223 in. (31 mm)	0.120 in. (3 mm)	1/4 - 20 UNC M6	
2	ST-GRW-02-XXX	C/F	1.02 in. (26 mm)	1.740 in. (44 mm)	1.223 in. (31 mm)	0.120 in. (3 mm)	1/4 - 20 UNC M6	
3	ST-GRW-03-XXX	C/F	1.300 in. (33 mm)	2.020 in. (51 mm)	1.223 in. (31 mm)	0.120 in. (3 mm)	1/4 - 20 UNC M6	
4	ST-GRW-04-XXX	C/F	1.580 in. (40 mm)	2.300 in. (58 mm)	1.223 in. (31 mm)	0.120 in. (3 mm)	1/4 - 20 UNC M6	
5	ST-GRW-05-XXX	C/F	2.050 in. (52 mm)	2.770 in. (70 mm)	1.223 in. (31 mm)	0.120 in. (3 mm)	1/4 - 20 UNC M6	
6	ST-GRW-06-XXX	C/F	2.600 in. (66 mm)	3.320 in. (84 mm)	1.223 in. (31 mm)	0.120 in. (3 mm)	1/4 - 20 UNC M6	
7	ST-GRW-07-XXX	C/F	4.250 in. (108 mm)	5.145 in. (131 mm)	1.223 in. (31 mm)	0.120 in. (3 mm)	1/4 - 20 UNC M6	
7A	ST-GRW-7A-XXX	C/F	4.948 in. (126 mm)	5.688 in. (144 mm)	1.223 in. (31 mm)	0.120 in. (3 mm)	1/4 - 20 UNC M6	

***Materials:** C Unplated Carbon Steel (Standard Material)
 T AISI 304 Grade Stainless Steel (A2 - 1.4301/1.4305)
 X AISI 316 Grade Stainless Steel (A4 - 1.4401/1.4571)
 Z Zinc Plated Steel

Threads: Omit As ordered above, the weld plates have standard UNC Thread
 -MET By adding the "-MET" designation after the material designation above, the threads are M6 Metric Thread

XXX Number of positions (ex. 005)

Standard Series Pipe Clamps

Rail Mounting Selection and Dimensions

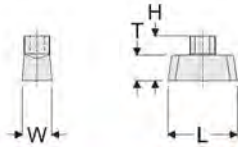

Rail Nut [RCN-0 / MRN-0]						
Grp.	Order Number	L	W	T	H	Thread Weight Ea.
0-7A	ST-RCN-99- RN0	0.950 in. (24 mm)	0.405 in. (10.4 mm)	0.190 in. (5 mm)	0.570 in. (14.5 mm)	1/4-20 UNC 0.02 lbs
0-7A	ST-MRN-99- RN0	0.950 in. (24 mm)	0.405 in. (10.4 mm)	0.190 in. (5 mm)	0.570 in. (14.5 mm)	M6 0.02 lbs

***Materials:**

- Z Zinc Plated Steel (Standard Material)
- T AISI 304 Grade Stainless Steel (A2 - 1.4301/1.4305)
- X AISI 316 Grade Stainless Steel (A4 - 1.4401/1.4571)
- C Unplated Carbon Steel (Special Material)

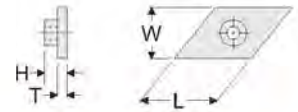

Rail Nut [RCN-1 / MRN-1]						
Grp.	Order Number	L	W	T	H	Thread Weight Ea.
0-7A	ST-RCN-99- RN1	1.075 in. (27 mm)	0.783 in. (20 mm)	0.175 in. (4 mm)	0.405 in. (10 mm)	1/4-20 UNC 0.04 lbs
0-7A	ST-MRN-99- RN1	1.075 in. (27 mm)	0.783 in. (20 mm)	0.175 in. (4 mm)	0.405 in. (10 mm)	M6 0.04 lbs

***Materials:**

- Z Zinc Plated Steel (Standard Material)
- T AISI 304 Grade Stainless Steel (A2 - 1.4301/1.4305)
- X AISI 316 Grade Stainless Steel (A4 - 1.4401/1.4571)
- C Unplated Carbon Steel (Special Material)

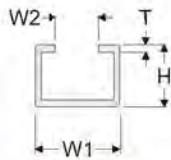

Mounting Rail [RAL-0]							
Grp.	Order Number	W1	W2	T	H	Length	Weight
0-7A	ST-RA0-99- XXX	1.125 in. (28 mm)	0.438 in. (11 mm)	14 gauge	0.438 in. (11 mm)	6FT 3FT	3.94 lbs 1.97 lbs

***Materials:**

- C Unplated Carbon Steel (Standard Material)
- T AISI 304 Grade Stainless Steel (A2 - 1.4301/1.4305)
- X AISI 316 Grade Stainless Steel (A4 - 1.4401/1.4571)
- Z Zinc Plated Steel

XXX Length: 6FT 72 in. (1829 mm) length (Standard Length)
3FT 36 in. (914 mm) length (special Length)

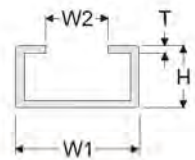

Mounting Rail [RAL-1]							
Grp.	Order Number	W1	W2	T	H	Length	Weight
0-7A	ST-RA1-99- XXX	1.438 in. (36.5 mm)	0.625 in. (16 mm)	14 gauge	0.438 in. (11 mm)	6FT 3FT	4.65 lbs 2.33 lbs

***Materials:**

- Z Zinc Plated Steel (Standard Material)
- T AISI 304 Grade Stainless Steel (A2 - 1.4301/1.4305)
- X AISI 316 Grade Stainless Steel (A4 - 1.4401/1.4571)
- C Unplated Carbon Steel

XXX Length: 6FT 72 in. (1829 mm) length (Standard Length)
3FT 36 in. (914 mm) length (special Length)

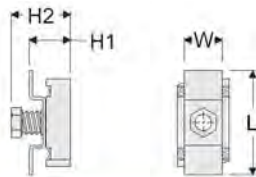

Strut Clip Nut [UCN]						
Grp.	Order Number	L	W	H1	H2	Thread Weight Ea.
0-7A	ST-UCN-99- N	1.600 in. (41 mm)	0.640 in. (16 mm)	0.525 in. (13 mm)	0.813 in. (21 mm)	1/4-20 UNC 0.10 lbs

***Materials:**

- Z Zinc Plated Steel (Standard Material)
- T AISI 304 Grade Stainless Steel (A2 - 1.4301/1.4305)
- X AISI 316 Grade Stainless Steel (A4 - 1.4401/1.4571)
- C Unplated Carbon Steel (Special Material)



Cover Washer [COW]				
Grp.	Order Number	ØD1	ØD2	T Weight Ea.
0-7A	ST-COW-99- *	0.630 in. (16mm)	0.265 in. (7mm)	0.117 in. (3 mm) 0.01 lbs

***Materials:**

- Z Zinc Plated Steel (Standard Material)
- T AISI 304 Grade Stainless Steel (A2 - 1.4301/1.4305)
- X AISI 316 Grade Stainless Steel (A4 - 1.4401/1.4571)
- C Unplated Carbon Steel (Special Material)

www.behringersystems.com

Standard Series Pipe Clamps

Fastening Hardware Selection and Dimensions

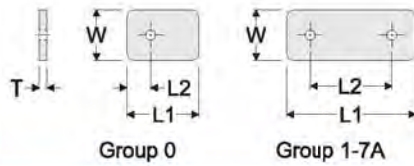

Cover Plate [COP]						
Grp.	Order Number	L1	L2	W	T	Weight Ea.
0	ST-COP-00 ^a	1.094 in. (28 mm)	0.370 in. (9 mm)	1.223 in. (31mm)	0.120 in. (3 mm)	0.04 lbs
1	ST-COP-01 ^a	1.362 in. (36 mm)	0.790 in. (20 mm)	1.223 in. (31mm)	0.120 in. (3 mm)	0.05 lbs
2	ST-COP-02 ^a	1.592 in. (40 mm)	1.020 in. (26 mm)	1.223 in. (31mm)	0.120 in. (3 mm)	0.06 lbs
3	ST-COP-03 ^a	1.872 in. (48 mm)	1.300 in. (33 mm)	1.223 in. (31mm)	0.120 in. (3 mm)	0.07 lbs
4	ST-COP-04 ^a	2.152 in. (55 mm)	1.580 in. (40 mm)	1.223 in. (31mm)	0.120 in. (3 mm)	0.08 lbs
5	ST-COP-05 ^a	2.790 in. (71 mm)	2.050 in. (52 mm)	1.223 in. (31mm)	0.120 in. (3 mm)	0.10 lbs
6	ST-COP-06 ^a	3.340 in. (85 mm)	2.600 in. (66 mm)	1.223 in. (31mm)	0.120 in. (3 mm)	0.15 lbs
7	ST-COP-07 ^a	5.020 in. (128 mm)	4.250 in. (108 mm)	1.223 in. (31mm)	0.120 in. (3 mm)	0.18 lbs
7A	ST-COP-7A ^a	5.776 in. (147 mm)	4.948 in. (126 mm)	1.223 in. (31mm)	0.120 in. (3 mm)	0.27 lbs

***Materials:** Z Zinc Plated Steel (Standard Material)
T AISI 304 Grade Stainless Steel (A2 - 1.4301/1.4305)
X AISI 316 Grade Stainless Steel (A4 - 1.4401/1.4571)

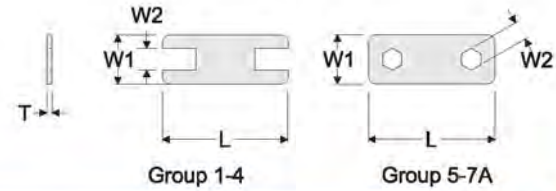

Safety Plate [SAF]						
Grp.	Order Number	L	W1	W2	T	Weight Ea.
0	N/A	-	-	-	-	-
1	ST-SAF-01 ^a	1.330 in. (34 mm)	1.125 in. (29 mm)	0.440 in. (11.2 mm)	0.045 in. (1 mm)	0.05 lbs
2	ST-SAF-02 ^a	1.560 in. (40 mm)	1.125 in. (29 mm)	0.440 in. (11.2 mm)	0.045 in. (1 mm)	0.06 lbs
3	ST-SAF-03 ^a	1.872 in. (48 mm)	1.125 in. (29 mm)	0.440 in. (11.2 mm)	0.045 in. (1 mm)	0.07 lbs
4	ST-SAF-04 ^a	2.120 in. (54 mm)	1.125 in. (29 mm)	0.440 in. (11.2 mm)	0.045 in. (1 mm)	0.08 lbs
5	ST-SAF-05 ^a	2.760 in. (70 mm)	1.125 in. (29 mm)	0.460 in. (11.7 mm)	0.045 in. (1 mm)	0.10 lbs
6	ST-SAF-06 ^a	3.340 in. (85 mm)	1.125 in. (29 mm)	0.460 in. (11.7 mm)	0.045 in. (1 mm)	0.15 lbs
7	ST-SAF-07 ^a	5.020 in. (128 mm)	1.125 in. (29 mm)	0.460 in. (11.7 mm)	0.045 in. (1 mm)	0.18 lbs
7A	C/F	-	-	-	-	-

***Materials:** Z Zinc Plated Steel (Standard Material)
T AISI 304 Grade Stainless Steel (A2 - 1.4301/1.4305)
X AISI 316 Grade Stainless Steel (A4 - 1.4401/1.4571)
C Unplated Carbon Steel (Special Material)

^a Consult Factory



Hexagon Head Bolt [HEX]				
Grp.	Order Number	L	Thread	Weight Ea.
0	ST-HEX-01 ^a	1.250 in. (30 mm)	1/4 - 20 UNC M6	0.02 lbs
1	ST-HEX-01 ^a	1.250 in. (30 mm)	1/4 - 20 UNC M6	0.02 lbs
2	ST-HEX-02 ^a	1.500 in. (35 mm)	1/4 - 20 UNC M6	0.02 lbs
3	ST-HEX-03 ^a	1.500 in. (35 mm)	1/4 - 20 UNC M6	0.02 lbs
4	ST-HEX-04 ^a	1.750 in. (45 mm)	1/4 - 20 UNC M6	0.03 lbs
5	ST-HEX-05 ^a	2.500 in. (65 mm)	1/4 - 20 UNC M6	0.04 lbs
6	ST-HEX-06 ^a	2.750 in. (70 mm)	1/4 - 20 UNC M6	0.04 lbs
7	ST-HEX-07 ^a	4.500 in. (114 mm)	1/4 - 20 UNC M6	0.06 lbs
7A	ST-HEX-7A ^a	5.000 in. (127 mm)	1/4 - 20 UNC M6	0.06 lbs

***Materials:** Z Zinc Plated Steel (Standard Material)
T AISI 304 Grade Stainless Steel (A2 - 1.4301/1.4305)
X AISI 316 Grade Stainless Steel (A4 - 1.4401/1.4571)

Threads: Omit As ordered above, the weld plates have standard 1/4 - 20 UNC Thread
-MET By adding the "-MET" designation after the material designation above, the threads are M6 Metric Thread

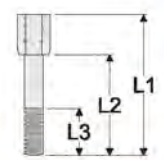

Stacking Bolt [STB]						
Grp.	Order Number	L1	L2	L3	Thread	Weight Ea.
0	ST-STB-00 ^a	1.438 in. (36.5 mm)	0.813 in. (21 mm)	0.75 in. (19 mm)	1/4 - 20 UNC M6	0.03 lbs.
1	ST-STB-00 ^a	1.438 in. (36.5 mm)	0.813 in. (21 mm)	0.75 in. (19 mm)	1/4 - 20 UNC M6	0.03 lbs.
2	ST-STB-02 ^a	1.688 in. (43 mm)	1.063 in. (27 mm)	0.75 in. (19 mm)	1/4 - 20 UNC M6	0.04 lbs.
3	ST-STB-02 ^a	1.688 in. (43 mm)	1.063 in. (27 mm)	0.75 in. (19 mm)	1/4 - 20 UNC M6	0.04 lbs.
4	ST-STB-04 ^a	1.938 in. (49 mm)	1.313 in. (33 mm)	0.75 in. (19 mm)	1/4 - 20 UNC M6	0.04 lbs.
5	ST-STB-05 ^a	2.688 in. (68 mm)	2.063 in. (52 mm)	0.75 in. (19 mm)	1/4 - 20 UNC M6	0.05 lbs.
6	ST-STB-06 ^a	2.938 in. (75 mm)	2.313 in. (59 mm)	0.75 in. (19 mm)	1/4 - 20 UNC M6	0.05 lbs.
7	ST-STB-07 ^a	4.688 in. (119 mm)	4.063 in. (103 mm)	0.75 in. (19 mm)	1/4 - 20 UNC M6	0.08 lbs.
7A	C/F	-	-	-	-	-

***Materials:** Z Zinc Plated Steel (Standard Material)
T AISI 304 Grade Stainless Steel (A2 - 1.4301/1.4305)
X AISI 316 Grade Stainless Steel (A4 - 1.4401/1.4571)
C Unplated Carbon Steel (Special Material)

Threads: omit As ordered above, the weld plates have standard 1/4 - 20 UNC thread
-MET By adding the "-MET" designation after the material designation above, the threads are M6 metric thread

^a Consult Factory

Standard Series Pipe Clamps

Complete Assembly Ordering Code

chart 1 chart 2 chart 3 chart 4 chart 5

S T 41050-PP-MET

Clamp Configuration chart 1

S	Complete Clamp for Weld Mounting
BS	Complete Clamp for Bolt Mounting
DS	Complete Double Clamp for Weld Mounting
R0S	Complete Clamp for mounting to RAL-0
R1S	Complete Clamp for mounting to RAL-1
US	Complete Clamp for mounting to Strut Channel
G*S	Complete Clamp for Group Weld Plate Mounting
SSK	Stacking Kit

Hardware Material chart 2

Omit	Electro-Zinc Dichromate Plating
T	AISI 304 Stainless Steel (A2 - 1.4301/1.4305)
X	AISI 316/316Ti Stainless Steel (A4 - 1.4401/1.4571)

Clamp Pair Material chart 4

PP	Polypropylene
SP	Santoprene (not available in group 0)
AL	Aluminum (not available in groups 0, 7, or 7A)

Threads chart 5

Omit	UNC Thread (Standard)
MET	Metric Thread

Clamp Group and Size chart 3

Behringer Group	Pipe Size	Tube Size	Metric ØD (mm)	Imperial ØD (Inch)	Order No.
0		1/4	6.40	0.250	0025
		3/8	9.50	0.375	0038
	1/8		10.00	0.405	00405
		1/2	12.70	0.500	0050
		5/8	16.00	0.625	0062
1		1/4	6.40	0.250	1025
			8.00	0.320	1032
		3/8	9.50	0.375	1038
	1/8		10.00	0.405	10405
2			12.00	0.472	10472
		3/8	9.50	0.375	2038
		1/2	12.70	0.500	2050
	1/4		13.70	0.540	20540
			15.00	0.591	2059
		5/8	16.00	0.625	2062
	3/8		17.10	0.675	20675
3		3/8	9.5	0.375	3038
			18.00	0.709	3070
		3/4	19.00	0.750	3075
			20.00	0.790	3079
	1/2		21.30	0.840	30840
		7/8	22.20	0.875	3087
		1	25.40	1.000	3100
4	3/4		26.70	1.050	41050
		1 1/8	28 3/5	1.125	41125
			30.00	1.181	41181
5		1 1/8	28.60	1.125	51125
		1 1/4	32.00	1.250	5125
	1		33.40	1.315	51315
			35.00	1.378	51378
		1 1/2	38.10	1.500	5150
	1		33.40	1.315	51315
			40.00	1.575	51575
		1 5/8	41.00	1.625	51625
6	1 1/4		42.20	1.660	51660
		1 3/4	44.50	1.750	6175
	1 1/2		48.30	1.900	61900
		2	50.80	2.000	6200
7			53.00	2.087	62087
		2 1/4	57.20	2.250	7225
	2		60.30	2.375	72375
		2 1/2	63.50	2.500	7250
	2 1/2		73.00	2.875	72875
		3	76.20	3.000	7300
7A	3	3 1/2	88.90	3.500	7350
		4	102.00	4.000	7A400
	4	4 1/2	114.30	4.500	7A450

Standard Series Pipe Clamps

Ordering Examples

Single Clamp for Weld Mounting

S



Consists of:
 2 HEX bolts
 1 COP Cover Plate
 1 CLH Clamp Set (2 halves)
 1 STW Weld Plate

Double Clamp for Weld Mounting

DS



Consists of:
 4 HEX bolts
 2 COP Cover Plates
 2 CLH Clamp Sets (4 halves)
 1 DOW Weld Plate

Clamp for Bolt Mounting

BS



Consists of:
 2 HEX bolts
 1 COP Cover Plate
 1 CLH Clamp Set (2 halves)
 1 BAP Base Plate

Stacking Kit

SSK



Consists of:
 2 STB Stacking Bolts
 1 SAF Safety Plate
 1 CLH Clamp Sets (2 halves)

Clamp for RAL-0 Mounting

R0S



Consists of:
 2 HEX bolts
 1 COP Cover Plate
 1 CLH Clamp Set (2 halves)
 2 RCN-0 Rail Nuts

Clamp for RAL-1 Mounting

R1S



Consists of:
 2 HEX bolts
 1 COP Cover Plate
 1 CLH Clamp Set (2 halves)
 2 RCN-1 Rail Nuts

Clamp for Strut Mounting

US



Consists of:
 2 HEX bolts
 1 COP Cover Plate
 1 CLH Clamp Set (2 halves)
 2 UCN Strut Clip Nuts

Clamp for Group Weld Mounting

G*S



Consists of:
 2 HEX bolts per position
 1 COP cover plate per position
 1 CLH clamp set per position
 1 GRW group weld plate
 Standard material for GRW is un-plated steel.

* is the number of positions
 Example: Group 2, 5 positions of 1/2" tube
 PP clamps 304SS = G5ST2050-PP

Heavy Series Pipe Clamps

Behringer's clamp pairs are available in different materials and incorporate a modular insert by group size. The robust Heavy Series design is larger and thicker than the Standard Series, and is designed for the toughest applications. Heavy Series pipe clamps are available in sizes from 1/4 in. (6.35mm) through 8.625 in. (219mm) outside diameter sizes, and various materials such as polypropylene, Santoprene, and aluminum. The clamp bore is offered in both the ribbed design for all sizes and now with a smooth bore design through group H6.

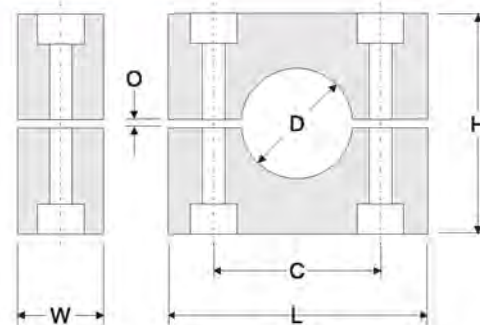

Ribbed Design

Smooth Bore



Clamp Pair Material Codes (*)

P	[PP] Polypropylene Black Color	S	[SP] Santoprene Beige Color	A	[AL] Aluminum Aluminum Color
----------	--	----------	---------------------------------------	----------	--

Clamp Pair Selection and Part Numbers

Behringer Group	Size	Metric OD (mm)	Imperial OD (Inch)	L	C	H	O	W	Weight Ea.	Ribbed Inside Clamp Pair (See material for *)	Smooth Bore Clamp Pair (See material for *)
H3	1/4 OD Tube	6.4	0.250	2.250 in. (57 mm)	1.300 in. (33 mm)	1.375 in. (35 mm)	0.063 in. (1.6 mm)	1.188 in. (30.2 mm)	0.07 lbs	HS-CLH-03- ^a -025	HS-CLH-03- ^a -025SB
	3/8 OD Tube	9.5	0.375							HS-CLH-03- ^a -038	HS-CLH-03- ^a -038SB
	1/8 Pipe	10.0	0.405							HS-CLH-03- ^a -041	HS-CLH-03- ^a -041SB
	1/2 OD Tube	12.7	0.500							HS-CLH-03- ^a -050	HS-CLH-03- ^a -050SB
	1/4 Pipe	13.7	0.540							HS-CLH-03- ^a -054	HS-CLH-03- ^a -054SB
	5/8 OD Tube	16.0	0.625							HS-CLH-03- ^a -062	HS-CLH-03- ^a -062SB
H4	3/8 Pipe	17.1	0.675	2.750 in. (70 mm)	1.770 in. (45 mm)	1.875 in. (48 mm)	0.063 in. (1.6 mm)	1.188 in. (30.2 mm)	0.09 lbs	HS-CLH-03- ^a -068	HS-CLH-03- ^a -068SB
	3/4 OD Tube	19.0	0.750							HS-CLH-04- ^a -075	HS-CLH-03- ^a -075SB
	20 mm	20.0	0.790							HS-CLH-04- ^a -079	HS-CLH-03- ^a -079SB
	1/2 Pipe	21.3	0.840							HS-CLH-04- ^a -084	HS-CLH-03- ^a -084SB
	7/8 OD Tube	22.2	0.875							HS-CLH-04- ^a -087	HS-CLH-03- ^a -087SB
	24 mm	24.0	0.944							HS-CLH-04- ^a -094	HS-CLH-03- ^a -094SB
	25 mm	25.0	0.984							HS-CLH-04- ^a -095	HS-CLH-03- ^a -095SB
	1 OD Tube	25.4	1.000							HS-CLH-04- ^a -098	HS-CLH-03- ^a -098SB
	3/4 Pipe	26.7	1.050							HS-CLH-04- ^a -100	HS-CLH-03- ^a -100SB
	28 mm	28.0	1.102							HS-CLH-04- ^a -105	HS-CLH-03- ^a -105SB
H5	30 mm	30.0	1.181	3.344 in. (87 mm)	2.360 in. (60 mm)	2.375 in. (60 mm)	0.063 in. (1.6 mm)	1.188 in. (30.2 mm)	0.15 lbs	HS-CLH-04- ^a -110	HS-CLH-03- ^a -110SB
	1 1/4 OD Tube	32.0	1.250							HS-CLH-04- ^a -118	HS-CLH-03- ^a -118SB
	1 Pipe	33.4	1.315							HS-CLH-06- ^a -125	HS-CLH-05- ^a -125SB
	1 1/2 OD Tube	38.1	1.500							HS-CLH-05- ^a -132	HS-CLH-05- ^a -132SB
H6	1 1/4 Pipe	42.2	1.660	4.500 in. (115 mm)	3.530 in. (90 mm)	3.500 in. (89 mm)	0.125 in. (3.2 mm)	1.688 in. (43 mm)	0.35 lbs	HS-CLH-05- ^a -150	HS-CLH-05- ^a -150SB
	1 Pipe	33.4	1.315							HS-CLH-05- ^a -166	HS-CLH-05- ^a -166SB
	1 1/4 Pipe	42.2	1.660							HS-CLH-06- ^a -166	HS-CLH-06- ^a -166SB
	1 3/4 OD Tube	44.5	1.750							HS-CLH-06- ^a -175	HS-CLH-06- ^a -175SB
	1 1/2 Pipe	48.3	1.900							HS-CLH-06- ^a -190	HS-CLH-06- ^a -190SB
	2 OD Tube	50.8	2.000							HS-CLH-06- ^a -199	HS-CLH-06- ^a -199SB
	2 1/8 OD Tube	54.0	2.125							HS-CLH-06- ^a -200	HS-CLH-06- ^a -200SB
	2 1/4 OD Tube	57.2	2.250							HS-CLH-06- ^a -213	HS-CLH-06- ^a -213SB
	2 Pipe	60.3	2.375							HS-CLH-06- ^a -225	HS-CLH-06- ^a -225SB
	2 1/2 OD Tube	63.5	2.500							HS-CLH-06- ^a -238	HS-CLH-06- ^a -238SB
	2 3/4 OD Tube	69.9	2.750							HS-CLH-06- ^a -250	HS-CLH-06- ^a -250SB
	H7	3 Pipe	88.9							3.500	6.000 in. (152 mm)
2 3/4 OD Tube		69.9	2.750	HS-CLH-07- ^a -275	HS-CLH-07- ^a -275SB						
2 1/2 OD Pipe		73.0	2.875	HS-CLH-07- ^a -288	HS-CLH-07- ^a -288SB						
3 OD Tube		76.2	3.000	HS-CLH-07- ^a -300	HS-CLH-07- ^a -300SB						
H8	3 Pipe	88.9	3.500	8.063 in. (205 mm)	6.620 in. (168 mm)	6.625 in. (168 mm)	0.188 in. (4.8 mm)	2.938 in. (74.6 mm)	2.31 lbs	HS-CLH-07- ^a -360	HS-CLH-07- ^a -360SB
	3 Pipe	88.9	3.500							HS-CLH-03- ^a -350	HS-CLH-03- ^a -350SB
	4 OD Tube	102	4.000							HS-CLH-03- ^a -400	HS-CLH-03- ^a -400SB
H9	4 Pipe	114	4.500	9.750 in. (248 mm)	8.060 in. (205 mm)	7.875 in. (200 mm)	0.188 in. (4.8 mm)	3.438 in. (87.3 mm)	2.59 lbs	HS-CLH-03- ^a -450	HS-CLH-03- ^a -450SB
	5 OD Tube	127	5.000							HS-CLH-03- ^a -500	HS-CLH-03- ^a -500SB
	5 OD Tube	127	5.000							HS-CLH-09- ^a -500	HS-CLH-09- ^a -500SB
	5 1/4 OD Tube	133	5.250							HS-CLH-09- ^a -525	HS-CLH-09- ^a -525SB
	5 Pipe	141	5.563							HS-CLH-09- ^a -556	HS-CLH-09- ^a -556SB
H10	6 OD Tube	152	6.000	12.500 in. (318 mm)	10.430 in. (265 mm)	10.625 in. (270 mm)	0.188 in. (4.8 mm)	4.438 in. (113 mm)	7.73 lbs	HS-CLH-09- ^a -600	HS-CLH-09- ^a -600SB
	6 Pipe	168	6.625							HS-CLH-09- ^a -663	HS-CLH-09- ^a -663SB
	6 Pipe	168	6.625							HS-CLH-10- ^a -663	HS-CLH-10- ^a -663SB
	7 OD Tube	178	7.000							HS-CLH-10- ^a -700	HS-CLH-10- ^a -700SB
H10	8 OD Tube	203	8.000							HS-CLH-10- ^a -800	HS-CLH-10- ^a -800SB
	8 Pipe	219	8.625							HS-CLH-10- ^a -863	HS-CLH-10- ^a -863SB

www.behringer.com

Heavy Series Pipe Clamps

Securing Plate Selection and Dimensions

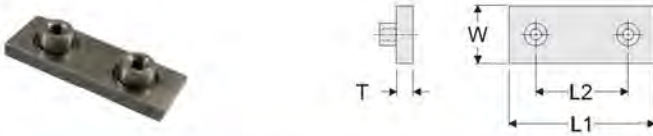

Single Weld Plate [SWP]							
Grp.	Order Number	L1	L2	W	T	Thread	Weight Ea.
H3	HS-SWP-03 [*]	2.875 in. (73 mm)	1.30 in. (33 mm)	1.25 in. (32 mm)	0.313 in. (8 mm)	3/8 - 16 UNC (M10)	0.34 lbs
H4	HS-SWP-04 [*]	3.375 in. (86 mm)	1.77 in. (45 mm)	1.25 in. (32 mm)	0.313 in. (8 mm)	3/8 - 16 UNC (M10)	0.39 lbs
H5	HS-SWP-05 [*]	4.000 in. (102 mm)	2.36 in. (60 mm)	1.25 in. (32 mm)	0.313 in. (8 mm)	3/8 - 16 UNC (M10)	0.45 lbs
H6	HS-SWP-06 [*]	5.875 in. (149 mm)	3.53 in. (90 mm)	1.75 in. (45 mm)	0.375 in. (10 mm)	7/16 - 14 UNC (M12)	1.10 lbs
H7	HS-SWP-07 [*]	7.375 in. (187 mm)	4.81 in. (122 mm)	2.25 in. (57 mm)	0.375 in. (10 mm)	5/8 - 11 UNC (M18)	1.71 lbs
H8	HS-SWP-08 [*]	10.000 in. (254 mm)	6.62 in. (168 mm)	3.00 in. (76 mm)	0.500 in. (13 mm)	3/4 - 10 UNC (M20)	4.15 lbs
H9	HS-SWP-09 [*]	11.750 in. (298 mm)	8.06 in. (205 mm)	3.50 in. (89 mm)	0.500 in. (13 mm)	7/8 - 9 UNC (M24)	5.83 lbs
H10	HS-SWP-10 [*]	14.500 in. (368 mm)	10.43 in. (265 mm)	4.50 in. (114 mm)	0.750 in. (19 mm)	1-1/8 - 7 UNC (M30)	13.65 lbs

***Materials:** C Unplated Carbon Steel (Standard Material)
 T AISI 304 Grade Stainless Steel (A2 - 1.4301/1.4305)
 X AISI 316 Grade Stainless Steel (A4 - 1.4401/1.4571)
 Z Zinc Plated Steel (Special Order)

Threads: omit As ordered above, the weld plates have standard UNC thread
 -MET By adding the "-MET" designation after the material designation above, the threads will be metric



Single Cover Plate [SCP]						
Grp.	Order Number	L1	L2	W	T	Weight Ea.
H3	HS-SCP-03 [*]	2.250 in. (57 mm)	1.30 in. (33 mm)	1.25 in. (32 mm)	0.313 in. (8 mm)	0.21 lbs
H4	HS-SCP-04 [*]	2.750 in. (70 mm)	1.77 in. (45 mm)	1.25 in. (32 mm)	0.313 in. (8 mm)	0.26 lbs
H5	HS-SCP-05 [*]	3.344 in. (85 mm)	2.36 in. (60 mm)	1.25 in. (32 mm)	0.313 in. (8 mm)	0.32 lbs
H6	HS-SCP-06 [*]	4.500 in. (114 mm)	3.53 in. (90 mm)	1.75 in. (45 mm)	0.375 in. (10 mm)	0.77 lbs
H7	HS-SCP-07 [*]	6.000 in. (152 mm)	4.81 in. (122 mm)	2.25 in. (57 mm)	0.375 in. (10 mm)	1.28 lbs
H8	HS-SCP-08 [*]	8.063 in. (205 mm)	6.62 in. (168 mm)	3.00 in. (76 mm)	0.500 in. (13 mm)	3.19 lbs
H9	HS-SCP-09 [*]	9.813 in. (249 mm)	8.06 in. (205 mm)	3.50 in. (89 mm)	0.500 in. (13 mm)	4.58 lbs
H10	HS-SCP-10 [*]	12.500 in. (318 mm)	10.43 in. (265 mm)	4.50 in. (114 mm)	0.750 in. (19 mm)	11.31 lbs

***Materials:** C Unplated Carbon Steel (Standard Material)
 T AISI 304 Grade Stainless Steel (A2 - 1.4301/1.4305)
 X AISI 316 Grade Stainless Steel (A4 - 1.4401/1.4571)
 Z Zinc Plated Steel (Special Order)

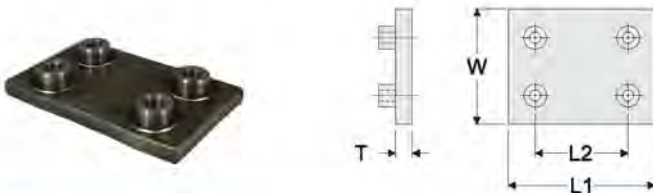

Double Weld Plate [DWP]							
Grp.	Order Number	L1	L2	W	T	Thread	Weight Ea.
H3	HS-DWP-03 [*]	2.875 in. (73 mm)	1.30 in. (33 mm)	2.50 in. (64 mm)	0.313 in. (8 mm)	3/8 - 16 UNC (M10)	0.72 lbs
H4	HS-DWP-04 [*]	3.375 in. (86 mm)	1.77 in. (45 mm)	2.50 in. (64 mm)	0.313 in. (8 mm)	3/8 - 16 UNC (M10)	0.78 lbs
H5	HS-DWP-05 [*]	4.000 in. (102 mm)	2.36 in. (60 mm)	2.50 in. (64 mm)	0.313 in. (8 mm)	3/8 - 16 UNC (M10)	0.90 lbs
H6	HS-DWP-06 [*]	5.875 in. (149 mm)	3.53 in. (90 mm)	3.50 in. (89 mm)	0.375 in. (10 mm)	7/16 - 14 UNC (M12)	2.20 lbs
H7	HS-DWP-07 [*]	7.375 in. (187 mm)	4.81 in. (122 mm)	4.50 in. (114 mm)	0.375 in. (10 mm)	5/8 - 11 UNC (M18)	3.42 lbs
H8	HS-DWP-08 [*]	10.000 in. (254 mm)	6.62 in. (168 mm)	7.00 in. (178 mm)	0.500 in. (13 mm)	3/4 - 10 UNC (M20)	8.30 lbs
H9	HS-DWP-09 [*]	11.750 in. (298 mm)	8.06 in. (205 mm)	7.00 in. (178 mm)	0.500 in. (13 mm)	7/8 - 9 UNC (M24)	11.75 lbs
H10	HS-DWP-10 [*]	14.500 in. (368 mm)	10.43 in. (265 mm)	9.375 in. (238 mm)	0.750 in. (19 mm)	1-1/8 - 7 UNC (M30)	28.00 lbs

***Materials:** C Unplated Carbon Steel (Standard Material)
 T AISI 304 Grade Stainless Steel (A2 - 1.4301/1.4305)
 X AISI 316 Grade Stainless Steel (A4 - 1.4401/1.4571)
 Z Zinc Plated Steel (Special Order)

Threads: omit As ordered above, the weld plates have standard UNC thread
 -MET By adding the "-MET" designation after the material designation above, the threads will be metric

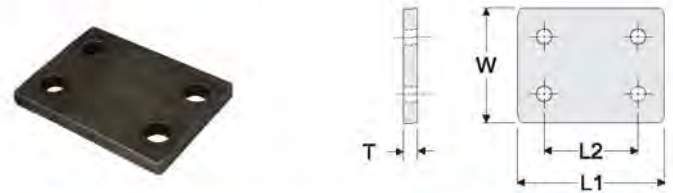

Double Cover Plate [DCP]						
Grp.	Order Number	L1	L2	W	T	Weight Ea.
H3	HS-DCP-03 [*]	2.250 in. (57 mm)	1.30 in. (33 mm)	2.50 in. (64 mm)	0.313 in. (8 mm)	0.42 lbs
H4	HS-DCP-04 [*]	2.750 in. (70 mm)	1.77 in. (45 mm)	2.50 in. (64 mm)	0.313 in. (8 mm)	0.52 lbs
H5	HS-DCP-05 [*]	3.344 in. (85 mm)	2.36 in. (60 mm)	2.50 in. (64 mm)	0.313 in. (8 mm)	0.64 lbs
H6	HS-DCP-06 [*]	4.500 in. (114 mm)	3.53 in. (90 mm)	3.50 in. (89 mm)	0.375 in. (10 mm)	1.54 lbs
H7	HS-DCP-07 [*]	6.000 in. (152 mm)	4.81 in. (122 mm)	4.50 in. (114 mm)	0.375 in. (10 mm)	2.56 lbs
H8	HS-DCP-08 [*]	8.063 in. (205 mm)	6.62 in. (168 mm)	7.00 in. (178 mm)	0.500 in. (13 mm)	6.38 lbs
H9	HS-DCP-09 [*]	9.813 in. (249 mm)	8.06 in. (205 mm)	7.00 in. (178 mm)	0.500 in. (13 mm)	9.16 lbs
H10	HS-DCP-10 [*]	12.500 in. (318 mm)	10.43 in. (265 mm)	9.375 in. (238 mm)	0.750 in. (19 mm)	22.62 lbs

***Materials:** C Unplated Carbon Steel (Standard Material)
 T AISI 304 Grade Stainless Steel (A2 - 1.4301/1.4305)
 X AISI 316 Grade Stainless Steel (A4 - 1.4401/1.4571)
 Z Zinc Plated Steel (Special Order)

Heavy Series Pipe Clamps

Fastening Hardware Selection and Dimensions



Hexagon Head Bolt [HEX]				
Grp.	Order Number	L	Thread	Weight Ea.
H3	HS-HEX-03-*	1.75 in. (44 mm)	3/8 - 16 UNC M10	0.06 lbs
H4	HS-HEX-04-*	2.25 in. (57 mm)	3/8 - 16 UNC M10	0.06 lbs
H5	HS-HEX-05-*	2.75 in. (70 mm)	3/8 - 16 UNC M10	0.09 lbs
H6	HS-HEX-06-*	4.00 in. (102 mm)	7/16 - 14 UNC M12	0.18 lbs
H7	HS-HEX-07-*	5.25 in. (133 mm)	5/8 - 11 UNC M16	0.50 lbs
H8	HS-HEX-08-*	7.50 in. (191 mm)	3/4 - 10 UNC M20	0.97 lbs
H9	HS-HEX-09-*	8.50 in. (216 mm)	7/8 - 9 UNC M24	1.56 lbs
H10	HS-HEX-10-*	11.75 in. (298 mm)	1-1/8 - 7 UNC M30	3.53 lbs

***Materials:**
C Unplated Carbon Steel (Standard Material)
T AISI 304 Grade Stainless Steel (A2 - 1.4301/1.4305)
X AISI 316 Grade Stainless Steel (A4 - 1.4401/1.4571)
Z Zinc Plated Steel (Standard Material)

Threads: **omit** As ordered above, the weld plates have standard 1/4 - 20 UNC Thread
-MET By adding the "-MET" designation after the material designation above, the threads are M6 Metric Thread

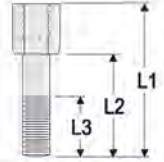

Stacking Bolt [STB]						
Grp.	Order Number	L1	L2	L3	Thread	Weight Ea.
H3	HS-STB-03-*	1.969 in. (50 mm)	0.906 in. (23 mm)	0.906 in. (23 mm)	3/8 - 16 UNC M10	0.10 lbs
H4	HS-STB-04-*	2.469 in. (63 mm)	1.406 in. (36 mm)	1.000 in. (25.4 mm)	3/8 - 16 UNC M10	0.11 lbs
H5	HS-STB-05-*	2.969 in. (75 mm)	1.906 in. (48 mm)	1.000 in. (25.4 mm)	3/8 - 16 UNC M10	0.13 lbs
H6	HS-STB-06-*	4.250 in. (108 mm)	2.875 in. (73 mm)	1.250 in. (32 mm)	7/16 - 14 UNC (M12)	0.24 lbs
H7	HS-STB-07-*	5.50 in. (140 mm)	3.875 in. (98 mm)	1.250 in. (32 mm)	5/8 - 11 UNC (M16)	0.49 lbs
H8	HS-STB-08-*	7.750 in. (197 mm)	5.750 in. (146 mm)	1.500 in. (38 mm)	3/4 - 10 UNC (M20)	1.15 lbs
H9	HS-STB-09-*	9.188 in. (233 mm)	7.000 in. (178 mm)	1.750 in. (44 mm)	7/8 - 9 UNC (M24)	1.85 lbs
H10	HS-STB-10-*	12.000 in. (305 mm)	9.500 in. (241 mm)	2.250 in. (57 mm)	1-1/8 - 7 UNC (M30)	2.50 lbs

***Materials:**
C Unplated Carbon Steel (Standard Material)
T AISI 304 Grade Stainless Steel (A2 - 1.4301/1.4305)
X AISI 316 Grade Stainless Steel (A4 - 1.4401/1.4571)
Z Zinc Plated Steel (Special Order)

Threads: **omit** As ordered above, the weld plates have standard UNC thread
-MET By adding the "-MET" designation after the material designation above, the threads will be metric

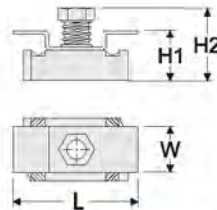

Strut Clip Nut [UCN]							
Grp.	Order Number	L	W	H1	H2	Thread	Weight Ea.
H3-H5	HS-UCN-345-*	1.500 in. (38 mm)	0.980 in. (25 mm)	0.728 in. (18.5 mm)	1.083 in. (27.5 mm)	3/8 - 16 UNC	0.2 lbs
H6	HS-UCN-06-*	1.790 in. (44 mm)	0.980 in. (25 mm)	0.810 in. (15.5 mm)	0.990 in. (25 mm)	7/16 - 14 UNC	0.3 lbs

***Materials:**
Z Zinc Plated Steel (Standard Material)
T AISI 304 Grade Stainless Steel (A2 - 1.4301/1.4305)
X AISI 316 Grade Stainless Steel (A4 - 1.4401/1.4571)

Threads: **omit** As ordered above, the weld plates have standard UNC thread
-MET By adding the "-MET" designation after the material designation above, the threads will be metric (Special for this item - call for info)

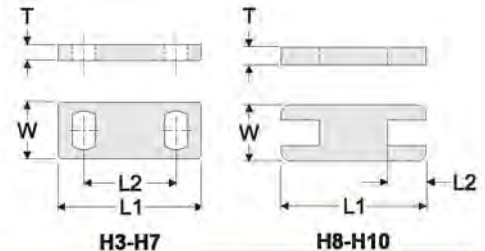

Safety Plate [SAF]						
Grp.	Order Number	L1	L2	W	T	Weight Ea.
H3	HS-SAF-03-*	2.281 in. (58 mm)	1.300 in. (33 mm)	1.219 in. (31 mm)	0.125 in. (3.2 mm)	0.06 lbs.
H4	HS-SAF-04-*	2.750 in. (70 mm)	1.770 in. (45 mm)	1.219 in. (31 mm)	0.125 in. (3.2 mm)	0.08 lbs.
H5	HS-SAF-05-*	3.344 in. (85 mm)	2.360 in. (60 mm)	1.219 in. (31 mm)	0.125 in. (3.2 mm)	0.11 lbs.
H6	HS-SAF-06-*	4.531 in. (115 mm)	3.530 in. (90 mm)	1.625 in. (41 mm)	0.188 in. (4.8 mm)	0.31 lbs.
H7	HS-SAF-07-*	5.938 in. (151 mm)	4.812 in. (122 mm)	2.125 in. (54 mm)	0.188 in. (4.8 mm)	0.58 lbs.
H8	HS-SAF-08-*	8.000 in. (203 mm)	1.313 in. (33 mm)	2.938 in. (75 mm)	0.375 in. (9.5 mm)	1.43 lbs.
H9	HS-SAF-09-*	9.750 in. (248 mm)	1.750 in. (44 mm)	3.438 in. (87 mm)	0.375 in. (9.5 mm)	2.17 lbs.
H10	HS-SAF-10-*	12.438 in. (316 mm)	1.906 in. (48 mm)	4.438 in. (113 mm)	0.250 in. (6.3 mm)	3.25 lbs.

***Materials:**
C Unplated Carbon Steel (Standard Material)
T AISI 304 Grade Stainless Steel (A2 - 1.4301/1.4305)
X AISI 316 Grade Stainless Steel (A4 - 1.4401/1.4571)
Z Zinc Plated Steel (Special Order)

www.behringersystems.com

Heavy Series Pipe Clamps

Rail Mounting Selection and Dimensions

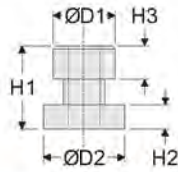

Rail Nut [RCN]							
Grp.	Order Number	ØD1	ØD2	H1	H2	H3	Thread
H3	HS-RCN-99*-RN7	0.698 in. (17.8 mm)	0.750 in. (19 mm)	0.750 in. (19 mm)	0.219 in. (5.6 mm)	0.297 in. (7.6 mm)	3/8 - 16 UNC
H4							M10
H5							
H6	HS-RCN-99*-RN8	0.778 in. (19.8 mm)	0.875 in. (22.2 mm)	0.813 in. (20.7 mm)	0.219 in. (5.6 mm)	0.359 in. (9.1 mm)	7/16 - 14 UNC M12
H7	HS-RCN-99*-RN9	0.938 in. (23.8 mm)	1.125 in. (28.6 mm)	1.700 in. (43.2 mm)	0.375 in. (9.5 mm)	1.075 in. (27.3 mm)	5/8 - 11 UNC M16
H8	N/A	-	-	-	-	-	
H9							
H10							
*Materials:	C	Unplated Carbon Steel (Standard Material)					
	T	AISI 304 Grade Stainless Steel (A2 - 1.4301/1.4305)					
	X	AISI 316 Grade Stainless Steel (A4 - 1.4401/1.4571)					
	Z	Zinc Plated Steel (Special Order)					
Threads:	omit	As ordered above, the weld plates have standard UNC thread.					
	-MET	By adding the "-MET" designation after the material designation above, the threads will be metric.					

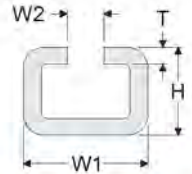

Mounting Rail [RAL-4]							
Grp.	Order Number	W1	W2	T	H	Length	Weight
H3-H7	HS-RA4-99*-XXX	1.563 in. (40 mm)	0.469 in. (12 mm)	0.188 in. (5 mm)	0.875 in. (22 mm)	2ME 1ME	16.8 lbs 8.4 lbs
*Materials:	C	Unplated Carbon Steel (Standard Material)					
	T	AISI 304 Grade Stainless Steel (A2 - 1.4301/1.4305)					
	X	AISI 316 Grade Stainless Steel (A4 - 1.4401/1.4571)					
	Z	Zinc Plated Steel (Special Order)					
XXX Length:	2ME	78 in. (2 mm) length (Standard Length)					
	1ME	36 in. (914 mm) length (special Length)					
		-Custom sizes available on request-					

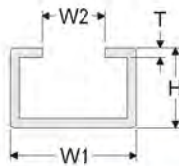

Mounting Rail [RAL-2]							
Grp.	Order Number	W1	W2	T	H	Length	Weight
H3-H5	HS-RA2-99*-XXX	1.750 in. (44.4 mm)	0.750 in. (19 mm)	0.125 in. (3 mm)	0.750 in. (19 mm)	6FT 3FT	8.7 lbs 4.4 lbs
*Materials:	C	Unplated Carbon Steel (Standard Material)					
	T	AISI 304 Grade Stainless Steel (A2 - 1.4301/1.4305)					
	X	AISI 316 Grade Stainless Steel (A4 - 1.4401/1.4571)					
	Z	Zinc Plated Steel (Special Order)					
XXX Length:	6FT	72 in. (1829 mm) length (Standard Length)					
	3FT	36 in. (914 mm) length (special Length)					
		-Custom sizes available on request-					

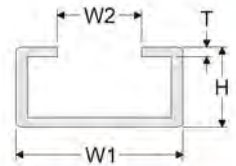

Mounting Rail [RAL-3]							
Grp.	Order Number	W1	W2	T	H	Length	Weight
H6	HS-RA3-06*-XXX	2.125 in. (54 mm)	1.000 in. (25.4 mm)	0.125 in. (3 mm)	0.813 in. (20.7 mm)	6FT 3FT	8 lbs 4 lbs
*Materials:	C	Unplated Carbon Steel (Standard Material)					
	T	AISI 304 Grade Stainless Steel (A2 - 1.4301/1.4305)					
	X	AISI 316 Grade Stainless Steel (A4 - 1.4401/1.4571)					
	Z	Zinc Plated Steel (Special Order)					
XXX Length:	6FT	72 in. (1829 mm) length (Standard Length)					
	3FT	36 in. (914 mm) length (special Length)					
		-Custom sizes available on request-					

Heavy Series Pipe Clamps

Complete Assembly Ordering Code

chart 1 chart 2 chart 3 chart 4 chart 5 chart 6
SH T 41050-PPSB-MET

Clamp Configuration chart 1	
SH	Single Heavy Complete Clamp for Weld Mounting
DH	Double Heavy Complete Clamp for Weld Mounting
R7H	Complete Clamp for mounting to RAL-4 (H3-H5)
R8H	Complete Clamp for mounting to RAL-4 (H6)
R9H	Complete Clamp for mounting to RAL-4 (H7)
UH	Complete Clamp for mounting to Strut Channel (H3-H6)
HSK	Heavy Stacking Kit
OH	Single Heavy Clamp with no Bottom Plate
BSH	Single Heavy Complete Clamp for Bolt Mounting

Hardware Material chart 2	
Omit	Untreated Carbon Steel
T	AISI 304 Stainless Steel (A2 - 1.4301/1.4305)
X	AISI 316/316Ti Stainless Steel (A4 - 1.4401/1.4571)
Z	Electro-Zinc Dichromate Plating

Clamp Pair Material chart 4	
PP	Polypropylene
SP	Santoprene
AL	Aluminum

Clamp Pair Design chart 5	
Omit	Ribbed Inside
SB	Smooth Bore Inside (groups H3-H6 only)

Threads chart 6	
Omit	UNC Thread (Standard)
MET	Metric Thread

Clamp Group and Size chart 3					
Behringer Group	Pipe Size	Tube Size	Metric OD (mm)	Imperial OD (Inch)	Clamp Halves
H3		1/4	6.4	0.250	3025
		3/8	9.5	0.375	3038
	1/8		10.0	0.405	30405
		1/2	12.7	0.500	3050
	1/4		13.7	0.540	30540
		5/8	16.0	0.620	3062
H4	3/8		17.1	0.675	30675
		3/4	19.0	0.750	4075
			20.0	0.790	4079
	1/2		21.3	0.840	40840
		7/8	22.2	0.875	4087
			25.0	0.984	40984
		1	25.4	1.000	4100
	3/4		26.7	1.050	41050
			30.0	1.181	41181
		1 1/4	32.0	1.250	5125
H5	1		33.4	1.315	51315
		1 1/2	38.1	1.500	5150
	1 1/4		42.2	1.660	51660
			42.2	1.660	61315
H6	1 1/4		42.2	1.660	61660
		1 3/4	44.5	1.750	6175
	1 1/2		48.3	1.900	61900
		2	50.8	2.000	6200
		2 1/8	54.0	2.125	62125
		2 1/4	57.2	2.250	6225
	2		60.3	2.375	62375
		2 1/2	63.5	2.500	6250
		2 3/4	69.9	2.750	6275
		2 3/4	69.9	2.750	7275
H7	2 1/2		73.0	2.875	72875
		3	76.2	3.000	7300
	3	3 1/2	88.9	3.500	7350
H8	3	3 1/2	88.9	3.500	83500
		4	102	4.000	8400
	4	4 1/2	114	4.500	8450
		5	127	5.000	8500
H9		5	127	5.000	9500
		5 1/4	133	5.250	9525
	5		141	5.563	95563
		6	152	6.000	9600
H10			168	6.625	96625
	6		168	6.625	06625
		7	178	7.000	0700
		8	203	8.000	0800
	8		219.0	8.625	08625

Heavy Series Pipe Clamps

Ordering Examples

Single Clamp for Weld Mounting

SH



Consists of:
2 HEX bolts
1 SCP Cover Plate
1 CLH Clamp Set (2 halves)
1 SWP Weld Plate

Double Clamp for Weld Mounting

DH



Consists of:
4 HEX bolts
1 DCP Double Cover Plate
2 CLH Clamp Sets (4 halves)
1 DWP Double Weld Plate

Rail Mounting [groups H3-H6]

**R7H
R8H**



Consists of:
2 HEX bolts
1 SCP Cover Plate
1 CLH Clamp Set (2 halves)
2 RCN Rail Nuts
groups H3-H5 use RCN-7
group H6 uses RCN-8

Rail Mounting [group H7]

R9H



Consists of:
2 HEX bolts
1 SCP Cover Plate
1 CLH Clamp Set (2 halves)
1 SPL Spacer Plate
2 RCN-9 Rail Nuts

Stacking kit

HSK



Consists of:
2 STB Stacking bolts
1 SAF Safety Plate
1 CLH Clamp Set (2 halves)

Strut Mounting [groups H3-H6]

UH



Consists of:
2 HEX bolts
1 SCP Cover Plate
1 CLH Clamp Set (2 halves)
2 UCN Strut Clip Nuts

Twin Series Pipe Clamps

Behringer's clamp pairs are available in different materials and incorporate a modular insert by group size. The Twin Series is available in sizes from 1/4 in. (6.35mm) through 1.660 in. (42mm) outside diameter sizes. The design of the twin series has 2 holes in one clamp, making it ideal for dual runs of pipe, tubing, or hose.

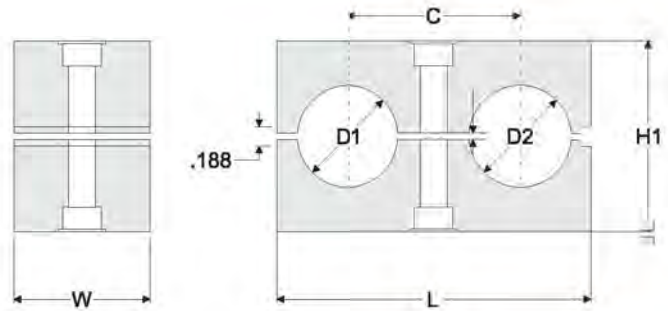

Clamp Pair Material Codes (*)

P	[PP] Polypropylene Black Color	S	[SP] Santoprene Beige Color
----------	--	----------	---------------------------------------

Clamp Pair Selection and Part Numbers

Behringer Group	Size	Metric ØD (mm)	Imperial ØD (Inch)	L	C	H	W	Weight Ea.	Clamp Pair (See material for *)	Smooth Bore Clamp Pair (See material for *)
T1	1/4 OD Tube	6.4	0.250	1.435 in. (36.5 mm)	0.787 in. (20 mm)	1.038 in. (26.4 mm)	1.195 in. (30.4 mm)	0.02 lbs	TS-CLH-01*-025	TS-CLH-01*-025SB
	3/8 OD Tube	9.5	0.375						TS-CLH-01*-038	TS-CLH-01*-038SB
	12 mm	12.0	0.472						TS-CLH-01*-047	TS-CLH-01*-047SB
T2	1/4 OD Tube	6.4	0.250	2.105 in. (53.5 mm)	1.142 in. (29 mm)	1.038 in. (26.4 mm)	1.195 in. (30.4 mm)	0.03 lbs	TS-CLH-02*-025	TS-CLH-02*-025SB
	3/8 OD Tube	9.5	0.375						TS-CLH-02*-038	TS-CLH-02*-038SB
	1/8 Pipe	10.0	0.405						TS-CLH-02*-041	TS-CLH-02*-041SB
	1/2 OD Tube	12.7	0.500						TS-CLH-02*-050	TS-CLH-02*-050SB
	1/4 Pipe	13.7	0.540						TS-CLH-02*-054	TS-CLH-02*-054SB
	5/8 OD Tube	16.0	0.625						TS-CLH-02*-062	TS-CLH-02*-062SB
	3/8 Pipe	17.0	0.675						TS-CLH-02*-068	TS-CLH-02*-068SB
T3	3/4 OD Tube	19.0	0.750	2.660 in. (67.6 mm)	1.417 in. (36 mm)	1.580 in. (40.1 mm)	1.195 in. (30.4 mm)	0.07 lbs	TS-CLH-03*-075	TS-CLH-03*-075SB
	1/2 Pipe	21.3	0.840						TS-CLH-03*-084	TS-CLH-03*-084SB
	7/8 OD Tube	22.2	0.875						TS-CLH-03*-087	TS-CLH-03*-087SB
	1 OD Tube	25.4	1.000						TS-CLH-03*-100	TS-CLH-03*-100SB
T4	7/8 OD Tube	22.2	0.875	3.313 in. (84.2 mm)	1.772 in. (45 mm)	1.750 in. (44.4 mm)	1.195 in. (30.4 mm)	0.09 lbs	TS-CLH-04*-087	TS-CLH-04*-087SB
	1 OD Tube	25.4	1.000						TS-CLH-04*-100	TS-CLH-04*-100SB
	3/4 Pipe	26.7	1.050						TS-CLH-04*-105	TS-CLH-04*-105SB
	1 1/8 OD Tube	28.6	1.125						TS-CLH-04*-112	TS-CLH-04*-112SB
T5	3/4 OD Tube	19.0	0.750	4.215 in. (107 mm)	2.205 in. (56 mm)	2.25 in. (57.1 mm)	1.195 in. (30.4 mm)	0.15 lbs	TS-CLH-05*-075	TS-CLH-05*-075SB
	1 1/4 OD Tube	32.0	1.250						TS-CLH-05*-125	TS-CLH-05*-125SB
	1 Pipe	33.4	1.315						TS-CLH-05*-132	TS-CLH-05*-132SB
	1 1/2 OD Tube	38.1	1.500						TS-CLH-05*-150	TS-CLH-05*-150SB
	1 1/4 Pipe	42.2	1.660						TS-CLH-05*-166	TS-CLH-05*-166SB

www.behringer.com

Twin Series Pipe Clamps

Hardware Selection and Dimensions

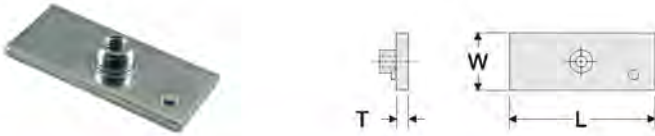

Twin Weld Plate [TWP]						
Grp.	Order Number	L	W	T	Thread	Weight Ea.
T1	TS-TWP-01-*	1.625 in. (41.3 mm)	1.20 in. (30.5 mm)	0.188 in. (5 mm)	1/4 - 20 UNC (M6)	0.09 lbs
T2	TS-TWP-02-*.XXX	2.188 in. (56 mm)	1.20 in. (30.5 mm)	0.188 in. (5 mm)	5/16 - 18 UNC (M8)	0.14 lbs
T3	TS-TWP-03-*.XXX	2.688 in. (68.3 mm)	1.20 in. (30.5 mm)	0.188 in. (5 mm)	5/16 - 18 UNC (M8)	0.17 lbs
T4	TS-TWP-04-*.XXX	3.445 in. (87.5 mm)	1.20 in. (30.5 mm)	0.188 in. (5 mm)	5/16 - 18 UNC (M8)	0.20 lbs
T5	TS-TWP-05-*.XXX	4.315 in. (110 mm)	1.20 in. (30.5 mm)	0.188 in. (5 mm)	5/16 - 18 UNC (M8)	0.26 lbs

***Materials:** Z Zinc Plated Steel (Standard Material)
 T AISI 304 Grade Stainless Steel (A2 - 1.4301/1.4305)
 X AISI 316 Grade Stainless Steel (A4 - 1.4401/1.4571)
 C Unplated Carbon Steel

XXX Threads: 56H 5/16 - 18 UNC Thread (Standard)
 38H 3/8 - 16 UNC Thread (Special)
 -MET Metric Thread as stated in chart (Special)

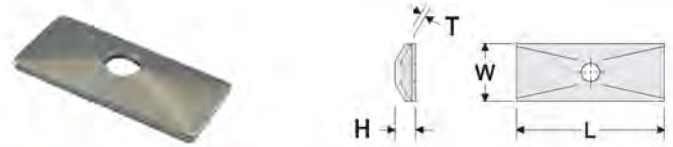

Twin Cover Plate [TCP]						
Grp.	Order Number	L	W	H	T	Weight Ea.
T1	TS-TCP-01-*	1.315 in. (33.4 mm)	1.09 in. (27.7 mm)	-	0.120 in. (3 mm)	0.04 lbs
T2	TS-TCP-02-*	2.040 in. (52 mm)	1.20 in. (30.5 mm)	0.266 in. (7 mm)	0.120 in. (3 mm)	0.08 lbs
T3	TS-TCP-03-*	2.542 in. (65 mm)	1.20 in. (30.5 mm)	0.266 in. (7 mm)	0.120 in. (3 mm)	0.10 lbs
T4	TS-TCP-04-*	3.150 in. (80 mm)	1.20 in. (30.5 mm)	0.266 in. (7 mm)	0.120 in. (3 mm)	0.11 lbs
T5	TS-TCP-05-*	4.125 in. (105 mm)	1.20 in. (31 mm)	0.266 in. (7 mm)	0.120 in. (3 mm)	0.14 lbs

***Materials:** Z Zinc Plated Steel (Standard Material)
 T AISI 304 Grade Stainless Steel (A2 - 1.4301/1.4305)
 X AISI 316 Grade Stainless Steel (A4 - 1.4401/1.4571)



Hexagon Head Bolt [HEX]				
Grp.	Order Number	L	Thread	Weight Ea.
T1	ST-HEX-01-*	1.25 in. (30 mm)	1/4 - 20 UNC (M6)	0.02 lbs
T2	TS-HEX-02-*.XXX	1.25 in. (35 mm)	5/16 - 18 UNC (M8)	0.03 lbs
T3	TS-HEX-03-*.XXX	1.75 in. (45 mm)	5/16 - 18 UNC (M8)	0.04 lbs
T4	TS-HEX-04-*.XXX	2.00 in. (50 mm)	5/16 - 18 UNC (M8)	0.05 lbs
T5	TS-HEX-05-*.XXX	2.25 in. (55 mm)	5/16 - 18 UNC (M8)	0.06 lbs

***Materials:** Z Zinc Plated Steel (Standard Material)
 T AISI 304 Grade Stainless Steel (A2 - 1.4301/1.4305)
 X AISI 316 Grade Stainless Steel (A4 - 1.4401/1.4571)

XXX Threads: 56H 5/16 - 18 UNC Thread (Standard)
 38H 3/8 - 16 UNC Thread (Special)
 -MET Metric Thread as stated in chart (Special)



Twin Stacking Bolt [STB]					
Grp.	Order Number	L1	L2	Thread	Weight Ea.
T1	CF*	-	-	-	-
T2	TS-STB-02-*.XXX	1.25 in. (32 mm)	0.625 in. (16 mm)	5/16 - 18 UNC (M8)	0.04 lbs
T3	TS-STB-03-*.XXX	1.75 in. (44 mm)	1.125 in. (29 mm)	5/16 - 18 UNC (M8)	0.05 lbs
T4	TS-STB-04-*.XXX	2.00 in. (50.8 mm)	1.375 in. (35 mm)	5/16 - 18 UNC (M8)	0.06 lbs
T5	TS-STB-05-*.XXX	2.50 in. (63 mm)	1.875 in. (48 mm)	5/16 - 18 UNC (M8)	0.06 lbs

***Materials:** Z Zinc Plated Steel (Standard Material)
 T AISI 304 Grade Stainless Steel (A2 - 1.4301/1.4305)
 X AISI 316 Grade Stainless Steel (A4 - 1.4401/1.4571)
 C Unplated Carbon Steel (Special Order)

XXX Threads: 56H 5/16 - 18 UNC Thread (Standard)
 38H 3/8 - 16 UNC Thread (Special)
 -MET Metric Thread as stated in chart (Special)

* Consult Factory

Twin Series Pipe Clamps

Rail and Strut Mounting Options

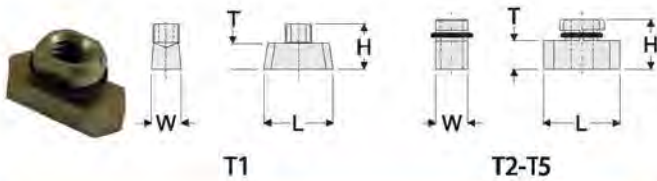

Twin Rail Nut [RCN-0]							
Group	Order Number	L	W	T	H	Thread	Weight Ea.
T1	ST-RCN-99- ^a -RN0	0.950 in. (24 mm)	0.405 in. (10.2 mm)	0.210 in. (5.3 mm)	0.570 in. (15 mm)	1/4 - 20 UNC (M6)	0.02 lbs
T2-T5	TS-RCN-99- ^a -RN0	1.000 in. (25.4 mm)	0.420 in. (10.7 mm)	0.210 in. (5.3 mm)	0.570 in. (15 mm)	5/16 - 18 UNC (M8)	0.02 lbs

***Materials:** Y Yellow Zinc Plated Steel (Standard Material Groups T2-T5)
 Z Zinc Plated Steel (Group T1 as Standard Material, Special T2-T5)
 T AISI 304 Grade Stainless Steel (A2 - 1.4301/1.4305)
 X AISI 316 Grade Stainless Steel (A4 - 1.4401/1.4571)
 C Unplated Carbon Steel (Special Material)

Twin Rail Nut [RCN-1/RCN-4]							
Grp.	Order Number	L	W	T	H	Thread	Weight Ea.
T1	ST-RCN-99- ^a -RN1	1.075 in. (27.3 mm)	0.783 in. (20 mm)	0.175 in. (4.4 mm)	0.405 in. (10 mm)	1/4-20 UNC (M6)	0.04 lbs
T2-T5	TS-RCN-99- ^a -RN4	1.075 in. (27.3 mm)	0.783 in. (20 mm)	0.175 in. (4.4 mm)	0.405 in. (10 mm)	5/16-18 UNC (M8)	0.04 lbs

***Materials:** Z Zinc Plated Steel (Group T1 Standard Material, Special T2-T5)
 T AISI 304 Grade Stainless Steel (A2 - 1.4301/1.4305)
 X AISI 316 Grade Stainless Steel (A4 - 1.4401/1.4571)
 C Unplated Carbon Steel (Special Material)



Mounting Rail [RAL-0]							
Group	Order Number	W1	W2	T	H	Length	Weight
0-7A	ST-RA0-99- ^a -XXX	1.125 in. (28 mm)	0.438 in. (11 mm)	14 gauge	0.438 in. (11 mm)	6FT 3FT	3.94 1.97

***Materials:** C Unplated Carbon Steel (Standard Material)
 T AISI 304 Grade Stainless Steel (A2 - 1.4301/1.4305)
 X AISI 316 Grade Stainless Steel (A4 - 1.4401/1.4571)
 Z Zinc Plated Steel

XXX Length: 6FT 72 in. (1829 mm) Length (Standard Length)
 3FT 36 in. (914 mm) Length (Special Length)
 -Custom sizes available on request-

Mounting Rail [RAL-1]							
Group	Order Number	W1	W2	T	H	Length	Weight
0-7A	ST-RA1-99- ^a -XXX	1.438 in. (36.5 mm)	0.625 in. (16 mm)	14 gauge	0.438 in. (11 mm)	6FT 3FT	4.65 2.33

***Materials:** Z Zinc Plated Steel (Standard Material)
 T AISI 304 Grade Stainless Steel (A2 - 1.4301/1.4305)
 X AISI 316 Grade Stainless Steel (A4 - 1.4401/1.4571)
 C Unplated Carbon Steel (Special Order)

XXX Length: 6FT 72 in. (1829 mm) Length (Standard Length)
 3FT 36 in. (914 mm) Length (Special Length)
 -Custom sizes available on request-



Twin Safety Plate [SAF]					
Grp.	Order Number	W	B	T	Weight Ea.
T1	N/A	-	-	-	-
T2-T5	TS-SAF-02- ^a	0.719 in. (18mm)	0.510 in. (13 mm)	0.050 in. (1.3 mm)	0.04 lbs

***Materials:** Y Yellow Zinc Plated Steel (Standard Material)
 Z Zinc Plated Steel (Special Material)
 T AISI 304 Grade Stainless Steel (A2 - 1.4301/1.4305)
 X AISI 316 Grade Stainless Steel (A4 - 1.4401/1.4571)
 C Unplated Carbon Steel (Special Material)

Strut Clip Nut [UCN]						
Group	Order Number	L	W	H1	H2	Thread
T1	ST-UCN-99- ^a	1.660 in. (42 mm)	0.635 in. (16 mm)	0.525 in. (13 mm)	0.813 in. (20.5 mm)	1/4 - 20 UNC
T2-T3	TS-UCN-23-2	1.500 in. (38 mm)	2.090 in. (53 mm)	0.730 in. (18.5 mm)	1.080 in. (27.5 mm)	5/16 - 18 UNC
T4-T5	TS-UCN-45-2	1.500 in. (38 mm)	3.150 in. (80 mm)	0.730 in. (18.5 mm)	1.080 in. (27.5 mm)	5/16 - 18 UNC

***Materials:** Z Zinc Plated Steel (Standard Material)
 T AISI 304 Grade Stainless Steel (A2 - 1.4301/1.4305)
 X AISI 316 Grade Stainless Steel (A4 - 1.4401/1.4571)
 C Unplated Carbon Steel (Special Order)

www.behringersystems.com

Twin Series Pipe Clamps

Complete Assembly Ordering Code

chart 1 chart 2 chart 3 chart 4 chart 5 chart 6
TW T 41050-PPSB - MET

Clamp Configuration chart 1	
TW	Complete Clamp for Weld Mounting
R0T	Complete Clamp for Mounting to RAL-0
R1T/R4T	Complete Clamp for Mounting to RAL-1
UT	Complete Clamp for Mounting to Strut Channel
TWSK	Complete Stacking Kit

Hardware Material chart 2	
Omit	Electro-Zinc Dichromate Plating
T	AISI 304 Stainless Steel (A2 - 1.4301/1.4305)
X	AISI 316/316Ti Stainless Steel (A4 - 1.4401/1.4571)
C	Untreated Carbon Steel

Clamp Pair Material chart 4	
PP	Polypropylene
SP	Santoprene

Clamp Pair Design chart 5	
Omit	Ribbed Inside
SB	Smooth Bore Inside (groups H3-H6 only)

Threads chart 6	
Omit	UNC Thread (Standard)
MET	Metric Thread

Clamp Group and Size chart 3					
Behringer Group	Pipe Size	Tube Size	Metric OD (mm)	Imperial OD (Inch)	Order No.
T1		1/4	6.4	0.250	1025
		3/8	9.5	0.375	1038
		12 mm	12.0	0.472	10472
T2		1/4	6.5	0.250	2025
		3/8	9.5	0.375	2038
	1/8		10.0	0.405	20405
		1/2	12.7	0.500	2050
	1/4		13.7	0.540	20540
		5/8	16.0	0.625	2062
T3		3/8	17.0	0.675	20675
		3/4	19.0	0.750	3075
	1/2		21.3	0.840	30840
		7/8	22.2	0.875	3087
T4		1	25.4	1.000	3100
		7/8	22.2	0.875	4087
		1	25.4	1.000	4100
	3/4		26.7	1.050	41050
		1 1/8	28.6	1.125	41125
T5		3/4	19.0	0.750	5075
		1 1/4	32.0	1.250	5125
	1		33.4	1.315	51315
		1 1/2	38.1	1.500	5150
	1 1/4		42.2	1.660	51660

Twin Series Pipe Clamps

Ordering Examples

Clamp for Weld Mounting

TW



Consists of:
1 HEX bolt
1 TCP Cover Plate
1 CLH Clamp Set (2 halves)
1 TWP Weld Plate

Stacking Kit

TWSK



Consists of:
1 STB Stacking bolt
1 SAF Safety Plate
1 CLH Clamp Set (2 halves)

Clamp for RAL-0 Mounting

R0T



Consists of:
1 HEX bolt
1 TCP Cover Plate
1 CLH Clamp Set (2 halves)
1 RCN-0 Rail Nut

Clamp for RAL-1 Mounting

R1T
R4T



Consists of:
1 HEX bolt
1 TCP Cover Plate
1 CLH Clamp Set (2 halves)
1 RCN-4 Rail Nut

Clamp for Strut Mounting

UT



Consists of:
1 HEX bolt
1 TCP Cover Plate
1 CLH Clamp Set (2 halves)
1 UCN Strut Clip Nut

Heavy-4 Series Pipe Clamps

Behringer's patented Heavy-4 Series pipe clamps accommodate pipe sizes from 8 through 30 inch. They feature a unique four-segmented plastic design which retains dimensional accuracy, absorbs vibration, resists stress and impact, and accomplishes a strong plastic-to-steel interface, strongly securing the largest pipes with ease. Substantial metal plates and bolts complement this heavyweight of the pipe clamp world.

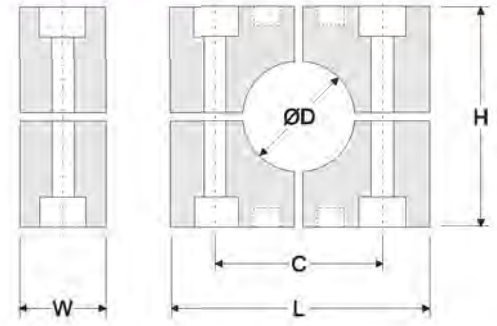

Clamp Pair Material Codes (*)			
P	[PP] Polypropylene Black Color	S	[SP] Santoprene Beige Color
		A	[AL] Aluminum Aluminum Color
***Please Note: For aluminum material, the clamp design will incorporate 2 halves, rather than a 4-segment design. For Santoprene material, minimum quantities may apply.			

Clamp Pair Dimensional Information

Group	Size	Metric ØD (mm)	Imperial ØD (Inch)	L	C	H	W	Weight	Clamp Halves (See material code for *)
H11	8 Pipe	219.0	8.625	18.250 in. (464 mm)	15.688 in. (398 mm)	16.000 in. (406 mm)	5.625 in. (143 mm)	24 lbs.	H4-CLH-11-*-08P
	10 Pipe	273.0	10.750						H4-CLH-11-*-10P
	12 Pipe	324.0	12.750						H4-CLH-11-*-12P
H12	14 Pipe	356.0	14.000	23.500 in. (597 mm)	20.875 in. (530 mm)	20.00 in. (508 mm)	5.625 in. (143 mm)	32 lbs.	H4-CLH-12-*-14P
	16 Pipe	406.0	16.000						H4-CLH-12-*-16P
H13	18 Pipe	457.0	18.000	24.750 in. (629 mm)	22.250 in. (565 mm)	22.000 in. (559 mm)	5.625 in. (143 mm)	22 lbs.	H4-CLH-13-*-18P
H14	20 Pipe	508.0	20.000	28.750 in. (730 mm)	26.250 in. (667 mm)	22.00 in. (559 mm)	5.625 in. (143 mm)	26 lbs.	H4-CLH-14-*-20P
	24 Pipe	610.0	24.000						27.50 in. (699 mm)
H15	30 Pipe	762.0	30.000	34.750 in. (883 mm)	32.250 in. (819 mm)	32.000 in. (813 mm)	5.625 in. (143 mm)	30 lbs.	H4-CLH-15-*-30P

Heavy-4 Series Pipe Clamps

Securing Plate Selection and Dimensions

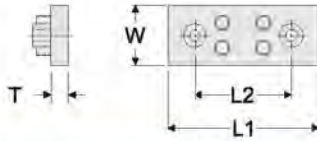

Single Weld Plate [SWP]							
Grp.	Order Number	L1	L2	W	T	Thread	Weight Ea.
H11	H4-SWP-11 ^a	20.000 in. (508 mm)	15.688 in. (398 mm)	5.875 in. (149 mm)	1.000 in. (25.4 mm)	1 1/4 - 7 UNC	34 lbs
H12	H4-SWP-12 ^a	25.500 in. (648 mm)	20.875 in. (530 mm)	5.875 in. (149 mm)	1.000 in. (25.4 mm)	1 1/4 - 7 UNC	43 lbs
H13	H4-SWP-13 ^a	27.000 in. (686 mm)	22.250 in. (565 mm)	5.875 in. (149 mm)	1.000 in. (25.4 mm)	1 1/4 - 7 UNC	46 lbs
H14	H4-SWP-14 ^a	30.500 in. (775 mm)	26.250 in. (667 mm)	5.875 in. (149 mm)	1.000 in. (25.4 mm)	1 1/4 - 7 UNC	52 lbs
H15	H4-SWP-15 ^a	36.500 in. (927 mm)	32.250 in. (819 mm)	5.875 in. (149 mm)	1.000 in. (25.4 mm)	1 1/4 - 7 UNC	62 lbs

***Materials:** C Unplated Carbon Steel (Standard Material)
 T AISI 304 Grade Stainless Steel (A2 - 1.4301/1.4305)
 X AISI 316 Grade Stainless Steel (A4 - 1.4401/1.4571)
 Z Zinc Plated Steel (Special Order)

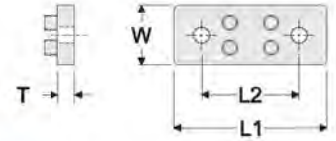

Single Cover Plate [SCP]							
Grp.	Order Number	L1	L2	W	T	Thread	Weight Ea.
H11	H4-SCP-11 ^a	18.250 in. (464 mm)	15.688 in. (398 mm)	5.875 in. (149 mm)	1.000 in. (25.4 mm)		28 lbs
H12	H4-SCP-12 ^a	23.500 in. (597 mm)	20.875 in. (530 mm)	5.875 in. (149 mm)	1.000 in. (25.4 mm)		37 lbs
H13	H4-SCP-13 ^a	25.000 in. (635 mm)	22.250 in. (565 mm)	5.875 in. (149 mm)	1.000 in. (25.4 mm)		40 lbs
H14	H4-SCP-14 ^a	29.000 in. (737 mm)	26.250 in. (667 mm)	5.875 in. (149 mm)	1.000 in. (25.4 mm)		45 lbs
H15	H4-SCP-15 ^a	35.000 in. (889 mm)	32.250 in. (819 mm)	5.875 in. (149 mm)	1.000 in. (25.4 mm)		55 lbs

***Materials:** C Unplated Carbon Steel (Standard Material)
 T AISI 304 Grade Stainless Steel (A2 - 1.4301/1.4305)
 X AISI 316 Grade Stainless Steel (A4 - 1.4401/1.4571)
 Z Zinc Plated Steel (Special Order)

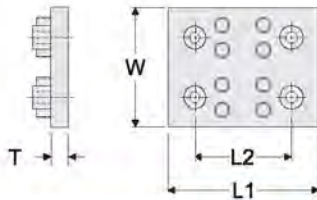

Double Weld Plate [DWP]							
Grp.	Order Number	L1	L2	W	T	Thread	Weight Ea.
H11	H4-DWP-11 ^a	20.000 in. (508 mm)	15.688 in. (398 mm)	11.750 in. (298 mm)	1.000 in. (25.4 mm)	1 1/4 - 7 UNC	71 lbs
H12	H4-DWP-12 ^a	25.500 in. (648 mm)	20.875 in. (530 mm)	11.750 in. (298 mm)	1.000 in. (25.4 mm)	1 1/4 - 7 UNC	88 lbs
H13	H4-DWP-13 ^a	27.000 in. (686 mm)	22.250 in. (565 mm)	11.750 in. (298 mm)	1.000 in. (25.4 mm)	1 1/4 - 7 UNC	93 lbs
H14	H4-DWP-14 ^a	30.500 in. (775 mm)	26.250 in. (667 mm)	11.750 in. (298 mm)	1.000 in. (25.4 mm)	1 1/4 - 7 UNC	106 lbs
H15	H4-DWP-15 ^a	36.500 in. (927 mm)	32.250 in. (819 mm)	11.750 in. (298 mm)	1.000 in. (25.4 mm)	1 1/4 - 7 UNC	127 lbs

***Materials:** C Unplated Carbon Steel (Standard Material)
 T AISI 304 Grade Stainless Steel (A2 - 1.4301/1.4305)
 X AISI 316 Grade Stainless Steel (A4 - 1.4401/1.4571)
 Z Zinc Plated Steel (Special Order)

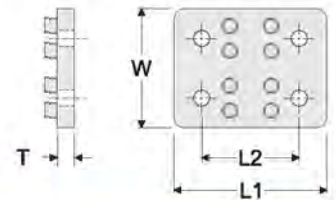

Double Cover Plate [DCP]							
Grp.	Order Number	L1	L2	W	T	Thread	Weight Ea.
H11	H4-DCP-11 ^a	18.250 in. (464 mm)	15.688 in. (398 mm)	11.750 in. (298 mm)	1.000 in. (25.4 mm)		60 lbs
H12	H4-DCP-12 ^a	23.500 in. (597 mm)	20.875 in. (530 mm)	11.750 in. (298 mm)	1.000 in. (25.4 mm)		77 lbs
H13	H4-DCP-13 ^a	25.000 in. (635 mm)	22.250 in. (565 mm)	11.750 in. (298 mm)	1.000 in. (25.4 mm)		82 lbs
H14	H4-DCP-14 ^a	29.000 in. (737 mm)	26.250 in. (667 mm)	11.750 in. (298 mm)	1.000 in. (25.4 mm)		96 lbs
H15	H4-DCP-15 ^a	35.000 in. (889 mm)	32.250 in. (819 mm)	11.750 in. (298 mm)	1.000 in. (25.4 mm)		115 lbs

***Materials:** C Unplated Carbon Steel (Standard Material)
 T AISI 304 Grade Stainless Steel (A2 - 1.4301/1.4305)
 X AISI 316 Grade Stainless Steel (A4 - 1.4401/1.4571)
 Z Zinc Plated Steel (Special Order)

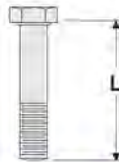

Hexagon Head Bolt [HEX]				
Grp.	Order Number	L	UNC Thread	Weight Ea.
H11	H4-HEX-11 ^a	17.500 in. (445 mm)	1 1/4 - 7 UNC	7.25 lbs.
H12	H4-HEX-12 ^a	21.500 in. (546 mm)	1 1/4 - 7 UNC	8.75 lbs.
H13	H4-HEX-13 ^a	24.000 in. (610 mm)	1 1/4 - 7 UNC	9.85 lbs.
H14	H4-HEX-14 ^a	27.500 in. (699 mm)	1 1/4 - 7 UNC	10.65 lbs.
H15	H4-HEX-15 ^a	33.500 in. (851 mm)	1 1/4 - 7 UNC	11.85 lbs.

***Materials:** C Unplated Carbon Steel (Standard Material)
 T AISI 304 Grade Stainless Steel (A2 - 1.4301/1.4305)
 X AISI 316 Grade Stainless Steel (A4 - 1.4401/1.4571)
 Z Zinc Plated Steel (Special Order)

www.behringersystems.com

Heavy-4 Series Pipe Clamps

Complete Assembly Ordering Code

chart 1 chart 2 chart 3 chart 4 chart 5
SH T 11275-PP-MET

Clamp Configuration chart 1	
SH	Single Heavy Complete Clamp for Weld Mounting
DH	Double Heavy Complete Clamp for Weld Mounting

Clamp Pair Material chart 4	
PP	Polypropylene
SP	Santoprene
AL	Aluminum
*For Aluminum, clamps are supplied in 2 halves rather than 4 quadrants. Some other dimensions will vary as well.	

Hardware Material chart 2	
Omit	Untreated Carbon Steel
T	AISI 304 Stainless Steel (A2 - 1.4301/1.4305)
X	AISI 316/316Ti Stainless Steel (A4 - 1.4401/1.4571)
Z	Electro-Zinc Dichromate Plating

Threads chart 5	
Omit	UNC Thread (Standard)
MET	Metric Thread

Clamp Group and Size chart 3				
Group	Pipe Size	Metric ØD (mm)	Imperial ØD (Inch)	Order No.
H11	8	219.0	8.625	11862
	10	273.0	10.750	11075
	12	324.0	12.750	11275
H12	14	356.0	14.000	12140
	16	406.0	16.000	12160
H13	18	457.0	18.000	13180
H14	20	508.0	20.000	14200
	24	610.0	24.000	14240
H15	30	762.0	30.000	15300

Ordering Examples

Single Heavy for Weld Mounting	
SH	 <p>Consists of: 2 HEX bolts 1 SCP Single Cover Plate 1 CLH Clamp Set (4 quarters) 1 SWP Single Weld Plate</p>

Double Heavy for Weld Mounting	
DH	 <p>Consists of: 4 HEX bolts 1 DCP Double Cover Plate 2 CLH Clamp Sets (8 quarters) 1 DWP Double Weld Plate</p>

Saddle Series Pipe Clamps

Long Saddle U-Bolt Clamp

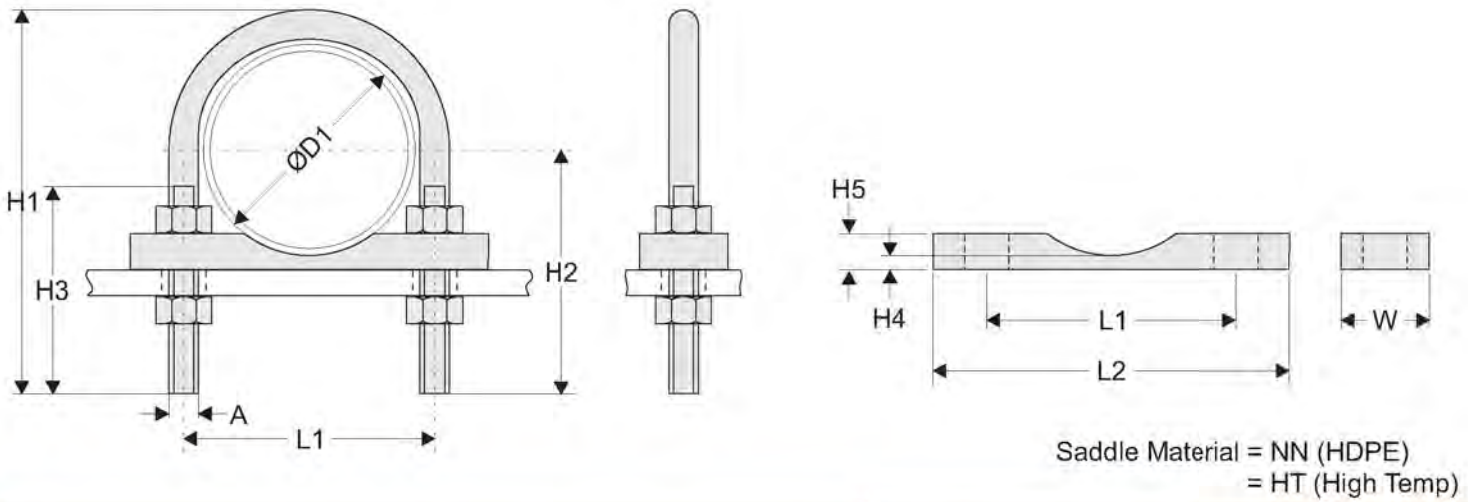

U-Bolt							
Nominal Pipe Size	ØD1 (pipe OD)	L1	H1	H2	H3	A (thread)	Wt. (lbs)
1/2	0.840	1.188	3.500	2.750	2.375	1/4-20 UNC	0.11
3/4	1.050	1.375	3.563	2.750	2.375	1/4-20 UNC	0.12
1	1.315	1.625	3.688	2.750	2.375	1/4-20 UNC	0.12
1 1/4	1.660	2.063	4.125	2.875	2.375	3/8-16 UNC	0.28
1 1/2	1.900	2.375	4.378	3.000	2.500	3/8-16 UNC	0.30
2	2.375	2.813	4.875	3.250	2.500	3/8-16 UNC	0.33
2 1/2	2.875	3.438	5.75	3.750	3.000	1/2-13 UNC	0.73
3	3.500	4.063	6.313	4.000	3.000	1/2-13 UNC	0.78
4	4.500	5.063	7.313	4.500	3.000	1/2-13 UNC	0.90
5	5.563	6.125	8.313	5.000	3.000	1/2-13 UNC	1.00
6	6.625	7.375	10.125	6.125	3.750	5/8-11 UNC	2.00
8	8.625	9.375	12.125	7.125	3.750	5/8-11 UNC	2.30
10	10.750	11.625	14.563	8.375	4.000	3/4-10 UNC	4.90
12	12.750	13.750	16.938	9.625	4.250	7/8-9 UNC	7.70
14	14.000	15.000	18.188	10.250	4.250	7/8-9 UNC	8.30
16	16.000	17.000	20.188	11.250	4.250	7/8-9 UNC	9.20
18	18.000	19.125	22.688	12.625	4.750	1-8 UNC	13.50
20	20.000	21.125	24.688	13.625	4.750	1-8 UNC	14.60
22	22.000	23.125	26.688	14.625	4.750	1-8 UNC	15.20
24	24.000	25.125	28.688	15.625	4.750	1-8 UNC	16.90
30	30.000	31.125	34.625	18.625	4.750	1-8 UNC	19.10

Long Saddle					
L1	L2	W	H4	H5	Wt. (lbs)
1.188	2.000	1.250	0.250	0.500	0.04
1.375	3.000	1.250	0.250	0.500	0.07
1.625	3.188	1.250	0.250	0.500	0.07
2.063	3.500	1.250	0.250	0.500	0.08
2.375	3.750	1.500	0.313	0.625	0.10
2.813	4.375	1.500	0.313	0.625	0.12
3.438	5.375	1.500	0.313	0.625	0.15
4.063	5.750	1.500	0.375	0.750	0.19
5.063	7.500	1.500	0.375	0.750	0.25
6.125	8.750	1.500	0.375	0.750	0.29
7.375	9.875	2.000	0.500	1.000	0.59
9.375	12.500	2.000	0.500	1.000	0.74
11.625	14.625	2.000	0.500	1.000	0.87
13.75	16.625	2.500	0.594	1.250	1.54
15.000	19.000	2.500	0.594	1.250	1.76
17.000	21.250	2.500	0.594	1.250	1.97
19.125	23.240	2.500	0.594	1.250	2.16
21.125	25.250	2.500	0.594	1.250	2.35
23.125	27.625	2.750	0.750	1.500	3.38
25.125	29.625	2.750	0.750	1.500	3.62
31.125	36.000	2.750	0.750	1.500	4.40

Assembly Ordering

LSUBZ-12750-NN

- Saddle Material**
NN = HDPE
HT = High Temp
- Pipe Diameter**
Enter ØD1 value from above, excluding decimal
- Material of U-Bolt**
Z Zinc Plated
T 304 Stainless Steel
X 316 Stainless Steel

U-Bolt Ordering

UBZ-12750

- Pipe Diameter**
Enter ØD1 value from above, excluding decimal
- Material of U-Bolt**
Z Zinc Plated
T 304 Stainless Steel
X 316 Stainless Steel

Saddle Ordering

LS-12750-NN

- Saddle Material**
NN = HDPE
HT = High Temp
- Pipe Diameter**
Enter ØD1 value from above, excluding decimal

Saddle Series Pipe Clamps

Short Saddle U-Bolt Clamp

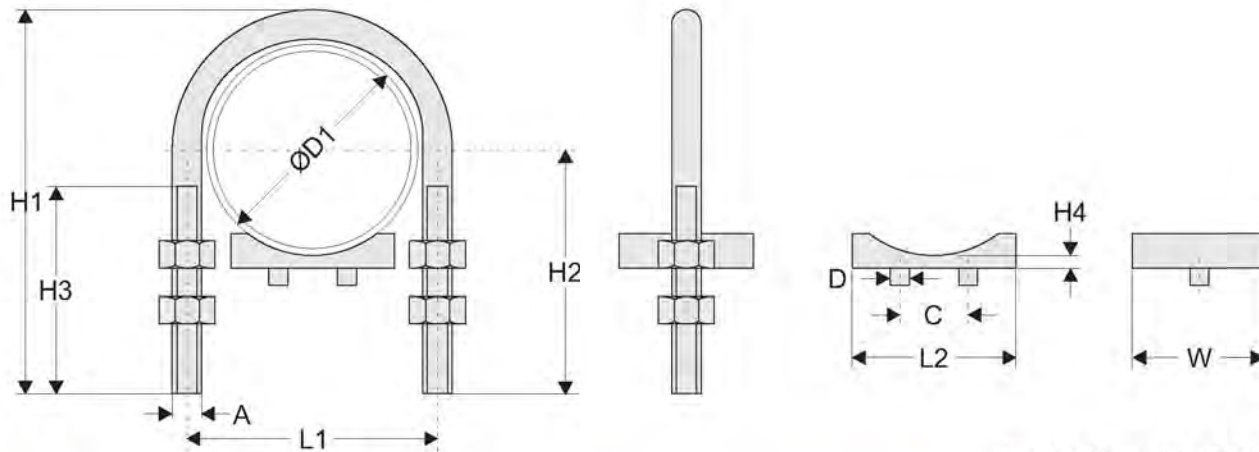

Saddle Material = PP (Polypropylene)

U-Bolt								Short Saddle				
Nominal Pipe Size	ØD1 (pipe OD)	L1	H1	H2	H3	A (thread)	Wt. (lbs)	L2	C	D	H4	W
1 1/4	1.660	2.063	4.125	2.875	2.375	3/8-16 UNC	0.28	1.500	1.000	0.313	0.250	1.000
1 1/2	1.900	2.375	4.378	3.000	2.500	3/8-16 UNC	0.30	1.500	1.000	0.313	0.250	1.000
2	2.375	2.813	4.875	3.250	2.500	3/8-16 UNC	0.33	1.500	1.000	0.313	0.250	1.000
3	3.500	4.063	6.313	4.000	3.000	1/2-13 UNC	0.78	3.000	1.563	0.563	0.313	2.000
4	4.500	5.063	7.313	4.500	3.000	1/2-13 UNC	0.90	3.000	1.563	0.563	0.313	2.000
6	6.625	7.375	10.125	6.125	3.750	5/8-11 UNC	2.00	5.500	3.500	1.000	0.375	3.000
8	8.625	9.375	12.125	7.125	3.750	5/8-11 UNC	2.30	5.500	3.500	1.000	0.375	3.000
10	10.750	11.625	14.563	8.375	4.000	3/4-10 UNC	4.90	5.500	3.500	1.000	0.375	3.000
12	12.750	13.750	16.938	9.625	4.250	7/8-9 UNC	7.70	8.500	5.875	1.125	0.375	3.000
14	14.000	15.000	18.188	10.250	4.250	7/8-9 UNC	8.30	8.500	5.875	1.125	0.375	3.000
16	16.000	17.000	20.188	11.250	4.250	7/8-9 UNC	9.20	8.500	5.875	1.125	0.375	3.000
18	18.000	19.125	22.688	12.625	4.750	1-8 UNC	13.50	8.500	5.875	1.125	0.375	3.000
20	20.000	21.125	24.688	13.625	4.750	1-8 UNC	14.60	14.000	10.500	1.125	0.500	4.000
24	24.000	25.125	28.688	15.625	4.750	1-8 UNC	16.90	14.000	10.500	1.125	0.500	4.000
30	30.000	31.125	34.625	18.625	4.750	1-8 UNC	19.10	14.000	10.500	1.125	0.500	4.000

Assembly Ordering

SSUBZ-12750-PP

Pipe Diameter
Enter ØD1 value from above, excluding decimal

Material of U-Bolt
Z Zinc Plated
T 304 Stainless Steel
X 316 Stainless Steel

U-Bolt Ordering

UBZ-12750

Pipe Diameter
Enter ØD1 value from above, excluding decimal

Material of U-Bolt
Z Zinc Plated
T 304 Stainless Steel
X 316 Stainless Steel

Saddle Ordering

SS-12750-PP

Saddle Material
PP Polypropylene

Pipe Diameter
Enter ØD1 value from above, excluding decimal

Cushion Clamps

Cushioned Clamping Systems

Behringer now offers a complete line of cushioned clamps. Cushioned clamps are typically used in pneumatic, refrigeration, HVAC, and some low pressure hydraulic lines. Behringer's cushioned clamps also eliminate metal to metal contact between the fluid lines and the support hardware. Standard material for the hardware is a clear trivalent zinc plated steel with options for both 304 and 316 grades stainless steel. Additional special options include aluminum and powder coating.



Specifications

Cushion:

Thermoplastic Elastomer
-65°F to 275°F operating temperature

Hardware:

Fits industry standard strut channel with 1-5/8 in. width.

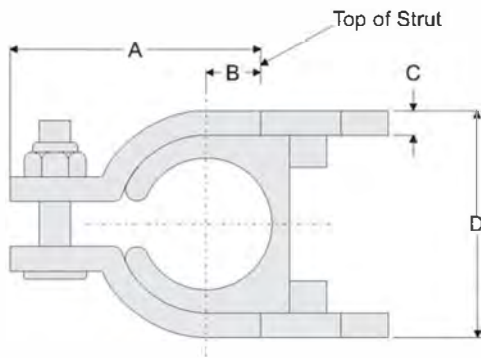

Cushion Ordering

Order Number Material

CC _____ - _____

Hardware Material

Z	Electro-Zinc Dichromate Plating
T	AISI 304 Stainless Steel (A2 - 1.4301/1.4305)
X	AISI 316/316Ti Stainless Steel (A4 - 1.4401/1.4571)

To order, use the ordering code above. Fill in the order number from the light blue shaded boxes in the chart to the right. Then add the material designation from the Hardware Materials chart above.

Ex. For 1 in. pipe with zinc plated hardware the order number is CC1315-Z.

Channel Ordering

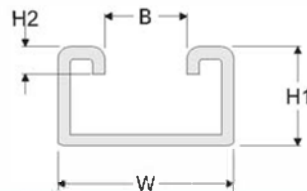

Strut Channel Rail

Height	Order Number	Length	H1	H2	W	B
7/8"	ST-SCR-088-*-048	48.0 in.	0.875 in. (22.2 mm)	0.281 in. (7 mm)	1.625 in. (41.4 mm)	0.875 in. (22.2 mm)
1"	ST-SCR-100-*-048	48.0 in.	1.0 in. (25.5 mm)	0.281 in. (7 mm)	1.625 in. (41.4 mm)	0.875 in. (22.2 mm)
	ST-SCR-100-*-120	120.0 in.				

*Materials:
 C Unplated Mild Steel
 T AISI 304 Grade Stainless (A2 - 1.4301/1.4305)
 X AISI 316 Grade Stainless (A4 - 1.4401/1.4571)
 Z Zinc Plated Steel

Cushion Clamp Size Table

Size	Order Number	OD	A	B	C	D*
1/4 T	0250	0.250	1.110	0.220	0.075	0.620
3/8 T	0375	0.375	1.240	0.280	0.075	0.750
1/2 T	0500	0.500	1.360	0.340	0.075	0.870
1/4 P	0540	0.540	1.410	0.630	0.075	0.910
5/8 T	0625	0.625	1.500	0.410	0.075	1.000
3/8 P	0675	0.675	1.590	0.450	0.075	1.070
3/4 T	0750	0.750	1.780	0.530	0.075	1.330
1/2 P	0840	0.840	1.910	0.590	0.075	1.450
7/8 T	0875	0.875	1.910	0.580	0.075	1.450
1 T	1000	1.000	2.030	0.660	0.105	1.660
3/4 P	1050	1.050	2.160	0.720	0.105	1.790
1 1/8 T	1125	1.125	2.160	0.720	0.105	1.790
1 1/4 T	1250	1.250	2.300	0.780	0.105	1.920
1 P	1315	1.315	2.750	0.910	0.119	2.220
1 3/8 T	1375	1.375	2.750	0.910	0.119	2.220
1 1/2 T	1500	1.500	2.750	0.910	0.119	2.220
1 5/8 T	1625	1.625	3.030	1.030	0.119	2.470
1 1/4 P	1660	1.660	3.030	1.030	0.119	2.470
1 3/4 T	1750	1.750	3.030	1.030	0.119	2.470
1 7/8 T	1875	1.875	3.280	1.160	0.119	2.470
1 1/2 P	1900	1.900	3.280	1.160	0.119	2.470
2 T	2000	2.000	3.280	1.160	0.119	2.470
1 1/8 T	2125	2.125	3.530	1.280	0.119	2.970
2 1/4 T	2250	2.250	3.780	1.410	0.119	3.220
2 3/8 T	2375	2.375	3.780	1.410	0.119	3.220
2 P	2375	2.375	3.780	1.410	0.119	3.220
2 1/2 T	2500	2.500	4.030	1.530	0.119	3.470
2 5/8 T	2625	2.625	4.030	1.530	0.119	3.470
2 1/2 P	2875	2.875	4.270	1.660	0.119	3.720
3 T	3000	3.000	4.520	1.780	0.119	3.970
3 1/8 T	3125	3.125	4.520	1.780	0.119	3.970
3 P	3500	3.500	4.910	1.970	0.119	4.360
3 5/8 T	3625	3.625	5.030	2.030	0.119	4.470
3 1/2 P	4000	4.000	5.530	2.280	0.119	4.970
4 1/8 T	4125	4.125	5.660	2.340	0.119	5.090
4 P	4500	4.500	6.030	2.530	0.119	5.470
5 P	5563	5.563	7.030	3.030	0.119	6.470
6 P	6625	6.625	8.030	3.530	0.119	7.470

Material Properties Technical Data

Clamp Pair Material Other materials have been used and are available upon request.	PP	SP	AL	NN
	Polypropylene	Santoprene	Aluminum	HDPE
Color	Black	Tan	Natural Aluminum	White
Description	Thermoplastic Copolymer	Thermoplastic Elastomer	AlSi12	High Density Polyethylene
Mechanical Properties				
Tensile Strength	3300 psi (at yield, 73 ° F) (ASTM D638)	1740 psi (at yield, 73 ° F) (ASTM D638)	19,000 psi (at yield, 73 ° F) (ASTM D638)	4500 psi (at yield, 73 ° F) (ASTM D638)
Tensile Elongation	6.6% (at yield, 73 ° F) (ASTM D638)	31% (at yield, 73 ° F) (ASTM D638)	3.5% (at yield, 73 ° F) (ASTM D638)	
Hardness		50 Shore D (ASTM D2240)		65 R (Rockwell "R" Scale)
Thermal Properties				
Temperature Range (Brief Exposure)	-22° F to + 215° F (-30° C to + 102° C)	-40° F to + 302° F (-40° C to + 150° C)	-65° F to + 750° F* ¹ (-54° C to + 399° C)	
Temperature Range (Continuous Exposure)	-22° F to + 194° F (-30° C to + 90° C)	-40° F to + 275° F (-40° C to + 135° C)	-65° F to + 500° F* ¹ (-54° C to + 260° C)	-58° F to + 175° F (-50° C to + 79° C)
Electrical Properties				
Dielectric Strength	475 V/mil (ASTM D149)	920 V/mil (ASTM D149)		510 V/mil (ASTM D149)
Dielectric Constant	2.26 - 2.36 (ASTM D150)	2.300 (ASTM D150)		2.35 (ASTM D150)
Volume Resistivity	> 2 x 10 ¹⁶ ohm-cm (ASTM D257)	>1 x 10 ¹⁴ ohm-cm (ASTM D257)	4.4 x 10 ⁶ ohm-cm (ASTM D257)	>6 x 10 ¹⁵ ohm-cm (ASTM D257)
Standards and Specifications				
	FDA Regulation Title 21 CFR 177.1520	UL Listed File# QMFZ2.E80017		FDA Regulation Title 21 CFR 177.1520
	Meets Multiple Automotive Industry Specifications	Meets Multiple Automotive Industry Specifications		ASTM D 1248-84 Type III, Class A
	EU Directive 2002/95/EC (RoHS) Compliant	EU Directive 2002/95/EC (RoHS) Compliant		Federal Specification LP-390 Type III, Class H, Grade I

Special Notes

Notes: *1: Tensile and fatigue strength rise as temperature decreases. The tensile elongation decreases as the temperature decreases.

The information contained in this document is provided as an aid in properly selecting products and/or options. It is intended to be used by technically experienced users for general reference only. The supplier assumes no responsibility or liability for the accuracy or completeness of this document, as well as results obtained by the use of this information. Due to the variety of possible operating conditions, it is highly recommended that the user make their own tests to determine the safety and suitability of all products and combinations thereof. The user is solely responsible for final determination of such conditions.

Standard Series Complete Assembly Dimensions

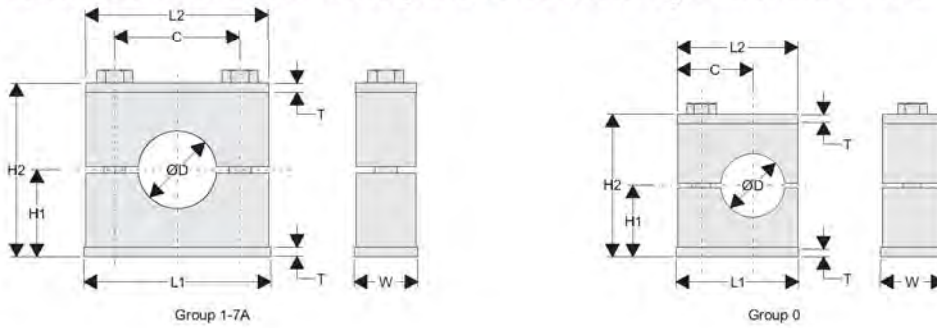

Clamp Assembly Dimensions

Behringer Group	OD	L1	L2	C	H1	H2	T	W
0	See ordering code on page 6 for available diameters.	1.188 (30.2)	1.094 (27.8)	0.420 (10.7)	0.675 (17.1)	1.350 (34.3)	0.120 (3)	1.223 (31)
1		1.510 (38.4)	1.362 (34.6)	0.790 (20.1)	0.660 (16.8)	1.320 (33.5)	0.120 (3)	1.223 (31)
2		1.740 (44.2)	1.592 (40.4)	1.020 (25.9)	0.760 (19.3)	1.520 (38.6)	0.120 (3)	1.223 (31)
3		2.020 (51.3)	1.872 (47.5)	1.300 (33)	0.810 (20.6)	1.620 (41.1)	0.120 (3)	1.223 (31)
4		2.300 (58.4)	2.152 (54.7)	1.580 (40.1)	0.938 (23.8)	1.875 (47.6)	0.120 (3)	1.223 (31)
5		2.770 (70.4)	2.790 (70.9)	2.050 (52.1)	1.313 (33.3)	2.625 (66.7)	0.120 (3)	1.223 (31)
6		3.320 (84.3)	3.340 (84.8)	2.600 (66)	1.438 (36.5)	2.875 (73)	0.120 (3)	1.223 (31)
7		5.020 (127.5)	5.020 (127.5)	4.250 (108)	2.313 (58.7)	4.625 (117.5)	0.120 (3)	1.223 (31)
7A		5.776 (146.7)	5.776 (146.7)	4.948 (125.7)	2.539 in(64.5)	5.078 (129)	0.120 (3)	1.223 (31)

Heavy Series Complete Assembly Dimensions

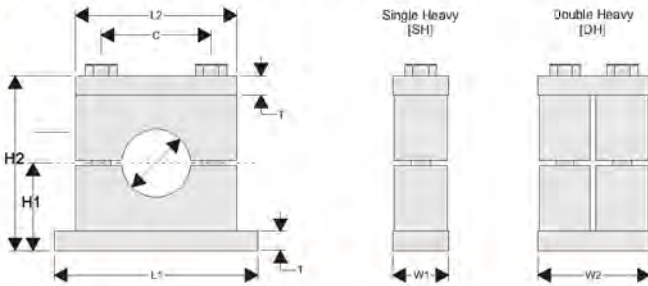

Clamp Assembly Dimensions

Behringer Group	OD	L1	L2	C	H1	H2	T	W1	W2
H3	See ordering code on page 12 for available diameters.	2.875 (73)	2.250 in(57)	1.300 (33)	1.000 (25.4)	2.000 (50.8)	0.313 (8)	1.250 (32)	2.500 (63.5)
H4		3.375 (86)	2.750 (70)	1.770 (45)	1.250 (32)	2.500 (63.5)	0.313 (8)	1.250 (32)	2.500 (63.5)
H5		4.000 (102)	3.344 (85)	2.360 (60)	1.500 (38)	3.000 (76.2)	0.313 (8)	1.250 (32)	2.500 (63.5)
H6		5.875 (149)	4.500 (114)	3.530 (90)	2.125 (54)	4.250 (108)	0.375 (10)	1.750 (44.5)	3.500 (88.9)
H7		7.375 (187)	6.000 (152)	4.810 (122)	2.750 (70)	5.500 (140)	0.375 (10)	2.250 (57.2)	4.500 (114)
H8		10.000 (254)	8.063 (205)	6.620 (168)	3.813 (97)	7.625 (194)	0.500 (13)	3.000 (76.2)	7.000 (178)
H9		11.750 (298)	9.750 (248)	8.060 (205)	4.438 (113)	8.875 (225)	0.500 (13)	3.500 (88.9)	7.000 (178)
H10		14.500 (368)	12.500 (318)	10.430 (265)	6.063 (154)	12.125 (308)	0.750 (19)	4.500 (114)	9.375 (238)

Twin Series Complete Assembly Dimensions

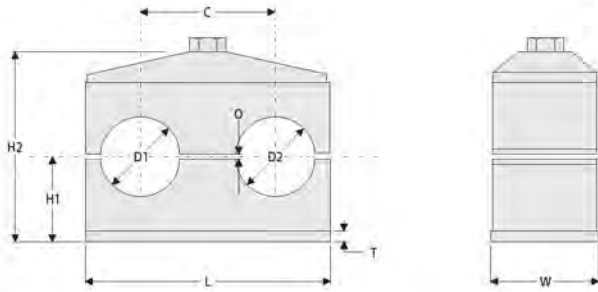

Clamp Assembly Dimensions

Behringer Group	D1/D2	L	C	H1	H2	T	W	O
T1	See Ordering code on page 18 for available dimensions	1.625 (41.3)	0.787 (20)	0.563 (14.3)	1.235 (31.4)	0.188 (5)	1.20 (30.5)	0.063 (1.6)
T2		2.188 (56)	1.142 (29)	0.688 (17.5)	1.454 (37)	0.188 (5)	1.20 (30.5)	0.063 (1.6)
T3		2.688 (68.3)	1.417 (36)	0.938 (23.8)	1.954 (49.6)	0.188 (5)	1.20 (30.5)	0.063 (1.6)
T4		3.445 (87.5)	1.772 (45)	1.063 (27)	2.204 (56)	0.188 (5)	1.20 (30.5)	0.063 (1.6)
T5		4.315 (110)	2.205 (56)	1.313 (33.3)	2.704 (68.7)	0.188 (5)	1.20 (30.5)	0.063 (1.6)

Heavy-4 Series Complete Assembly Dimensions

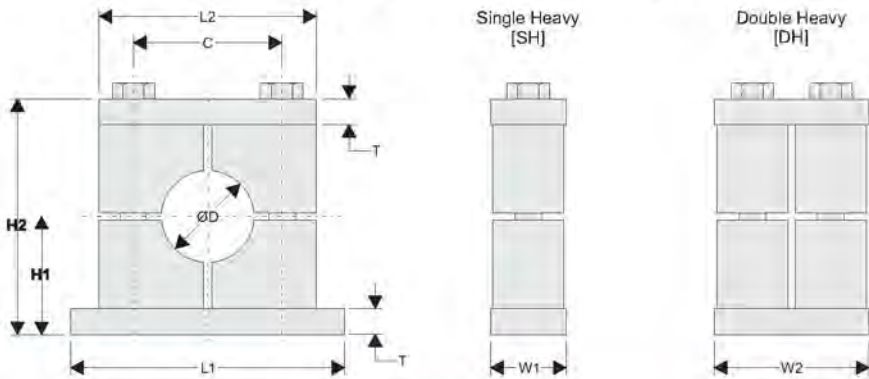

Clamp Assembly Dimensions

Behringer Group	OD	L1	L2	C	H1	H2	T	W1	W2
H11	See ordering code on page 25 for available diameters.	20.000 (508)	18.250 (464)	15.688 (398)	9.000 (229)	18.000 (457)	1.000 (25.4)	5.875 (149)	11.750 (298)
H12		25.000 (635)	23.500 (597)	20.875 (530)	11.000 (279)	22.000 (559)	1.000 (25.4)	5.875 (149)	11.750 (298)
H13		26.500 (673)	24.750 (629)	22.250 (565)	12.000 (305)	24.000 (610)	1.000 (25.4)	5.875 (149)	11.750 (298)
H14		30.000 (762)	28.750 (730)	26.250 (667)	12.000 (305)	24.000 (610)	1.000 (25.4)	5.875 (149)	11.750 (298)
H15		36.000 (914)	34.750 (883)	32.250 (819)	17.000 (432)	34.000 (864)	1.000 (25.4)	5.875 (149)	11.750 (298)

Tightening Torques and Maximum Loads

The charts below show the force in the direction of the pipe [P] required to move the pipe through the clamp. The values are for clamps with cover plates and hexagon head bolts using the recommended tightening torques below.

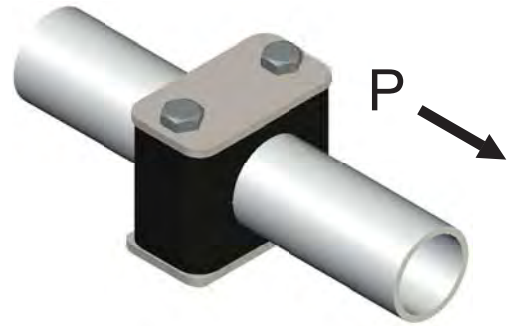

Standard Series							
Behringer Group	Hexagon Head Bolt	Polypropylene		Santoprene		Aluminum	
		Tightening Torque (Ft-lbs.)	Maximum load (lbs.) in pipe direction (P)	Tightening Torque (Ft-lbs.)	Maximum load (lbs.) in pipe direction (P)	Tightening Torque (Ft-lbs.)	Maximum load (lbs.) in pipe direction (P)
0	1/4 - 20 UNC	6	135	6	135	9	785
1		6	245	6	225	9	945
2		6	290	6	270	9	965
3		6	315	6	290	9	1100
4		6	335	6	315	9	1125
5		6	425	6	380	9	1600
6		6	450	6	405	9	2000
7		6	495	6	425	9	N/A
7A		6		6		9	N/A

Heavy Series							
Behringer Group	Hexagon Head Bolt	Polypropylene		Santoprene		Aluminum	
		Tightening Torque (Ft-lbs.)	Maximum load (lbs.) in pipe direction (P)	Tightening Torque (Ft-lbs.)	Maximum load (lbs.) in pipe direction (P)	Tightening Torque (Ft-lbs.)	Maximum load (lbs.) in pipe direction (P)
H3	3/8 - 16 UNC	9	360	9	335	22	2720
H4		9	650	9	600	22	3395
H5		11	740	11	675	25	3485
H6	7/16 - 14 UNC	22	1845	22	1755	40	6615
H7	5/8 - 11 UNC	33	2475	33	2025	90	7850
H8	3/4 - 10 UNC	60	3150	60	2700	160	15,885
H9	7/8 - 9 UNC	80	6300	80	5625	180	16,875
H10	1 1/8 - 7 UNC	130	9000	130	7650	370	19,000

Twin Series					
Behringer Group	Hexagon Head Bolt	Polypropylene		Santoprene	
		Tightening Torque (Ft-lbs.)	Maximum load (lbs.) in pipe direction (P)	Tightening Torque (Ft-lbs.)	Maximum load (lbs.) in pipe direction (P)
T1	1/4 - 20 UNC	4	100	4	100
T2	5/16 - 18 UNC	9	235	9	235
T3		9	235	9	235
T4		9	300	12	300
T5		6	300	6	300

Note: All tightening torques and static shearing forces apply to clamps with cover plates and hex bolts and are according to DIN3015-10. Pipe sliding starts when the load values "P" are reached.

Recommended Spacing

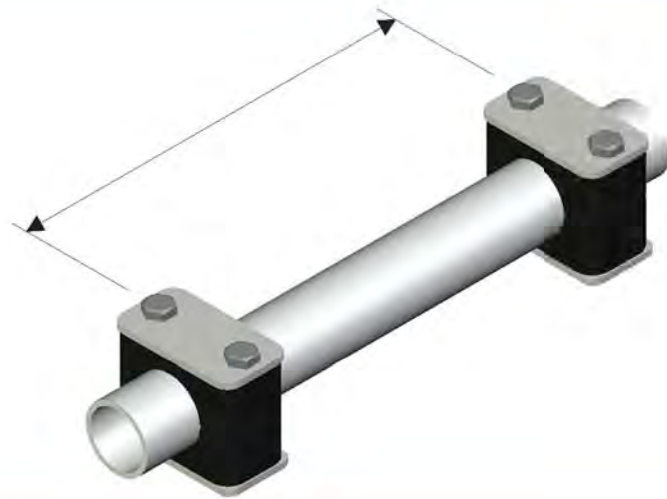

Recommended Spacing

Pipe or Tube OD	Operating Pressure	Recommended Spacing	Operating Pressure	Recommended Spacing
0.250 in. to 0.675 in.	up to 3000 psi	5 - 7 Ft.	over 3000 psi	3 - 5 Ft.
0.750 in. to 1.050 in.	up to 3000 psi	6 - 8 Ft.	over 3000 psi	4 - 6 Ft.
1.125 in. to 1.500 in.	up to 3000 psi	7 - 9 Ft.	over 3000 psi	5 - 7 Ft.
1.750 in. to 2.500 in.	up to 3000 psi	8 - 10 Ft.	over 3000 psi	6 - 8 Ft.
2.750 in. to 3.500 in.	up to 3000 psi	9 - 11 Ft.	over 3000 psi	7 - 9 Ft.
4.000 in. to 4.500 in.	up to 3000 psi	10 - 12 Ft.	over 3000 psi	8 - 10 Ft.
5.563 in. to 6.625 in.	up to 3000 psi	11 - 13 Ft.	over 3000 psi	8 - 11 Ft.
6.625 in. to 8.625 in.	up to 3000 psi	12 - 14 Ft.	over 3000 psi	9 - 11 Ft.
10.750 in. to 12.750 in.	up to 3000 psi	13 - 15 Ft.	over 3000 psi	8 - 10 Ft.
13.750 in. to 19.750 in.	up to 3000 psi	14 - 16 Ft.	over 3000 psi	10 - 12 Ft.

www.behringersystems.com

Recommended Mounting Practices

Bends

Behringer recommends that all pipe bends be supported by clamps placed as close to the bend as possible. The clamps should be directly after the connection (coupler, threaded connector, flange, or other).



Components

Behringer recommends that all system components be supported by clamps directly before and after the component in order to protect against vibrations and shock. The clamps should be located as close to the component as possible.



BEHRINGER[®]

For more information on Behringer Pipe Supports for industrial applications, visit our website:

behringersystems.com

Or call us at +1 (973) 948-0226

Your local stocking distributor:

Behringer Corporation
17 Ridge Road
Branchville, NJ 07826
Tel: +1 (973) 948-0226
Fax: +1 (973) 948-2562
email: sales@behringersystems.com
web: behringersystems.com